

INSTALLATION, OPERATION & MAINTENANCE INSTRUCTIONS

WOM

377 FLOAT CAGE / 326L & 322L LEVER VALVES

TABLE OF CONTENTS

Overview	Cover
General Information.....	Cover
Operation	4
Installation	4-6
Maintenance	7
Overhaul.....	7
Information Present.....	8-10
Specifications.....	11-13
Parts / Overhaul	14-15
Packing Adjustment.....	15
Parts Kits	16-18
Drawings	19-27

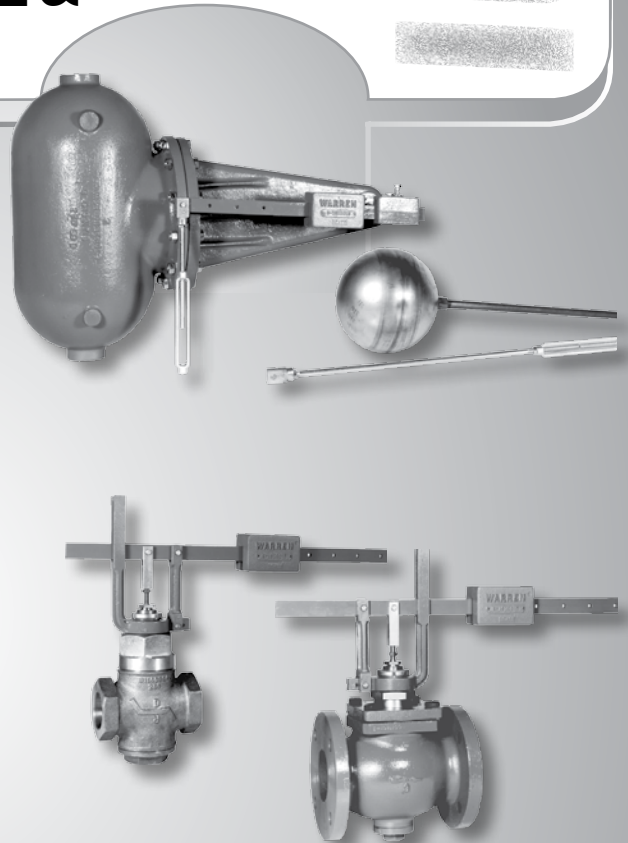

PRODUCT OVERVIEW

This document covers the installation, operation and maintenance of the 377 Float Cage and the 326L and 322L Lever Valves presented in the "Level Controls and Accessories", Product Specification.

GENERAL INFORMATION

The instructions given herein cover generally the operation and maintenance of subject equipment. Should any questions arise which may not be answered specifically by these instructions, they should be referred to Warren Controls Inc. for further detailed information and technical assistance. This manual cannot possibly cover every situation connected with the operation, adjustment, inspection, test, overhaul and maintenance of the equipment furnished. Every effort is made to prepare the text of this manual so

that engineering and design data is transformed into the most easily understood wording. Warren Controls Inc., in furnishing this equipment and this manual, must presume that the operation and maintenance personnel assigned thereto have sufficient technical knowledge and experience to apply sound safety and operational practices which may not be covered herein. In applications where Warren Controls Inc. furnished equipment is to be integrated with a process or other machinery, these instructions should be thoroughly reviewed to determine the proper integration of the equipment into the overall plant operational procedures. **Warren Controls does not assume responsibility for the selection, use, or maintenance of any product. Responsibility for proper selection, use, and maintenance of any Warren Controls product remains solely with the purchaser and end-user**



Warren Controls Level Controls at Work...

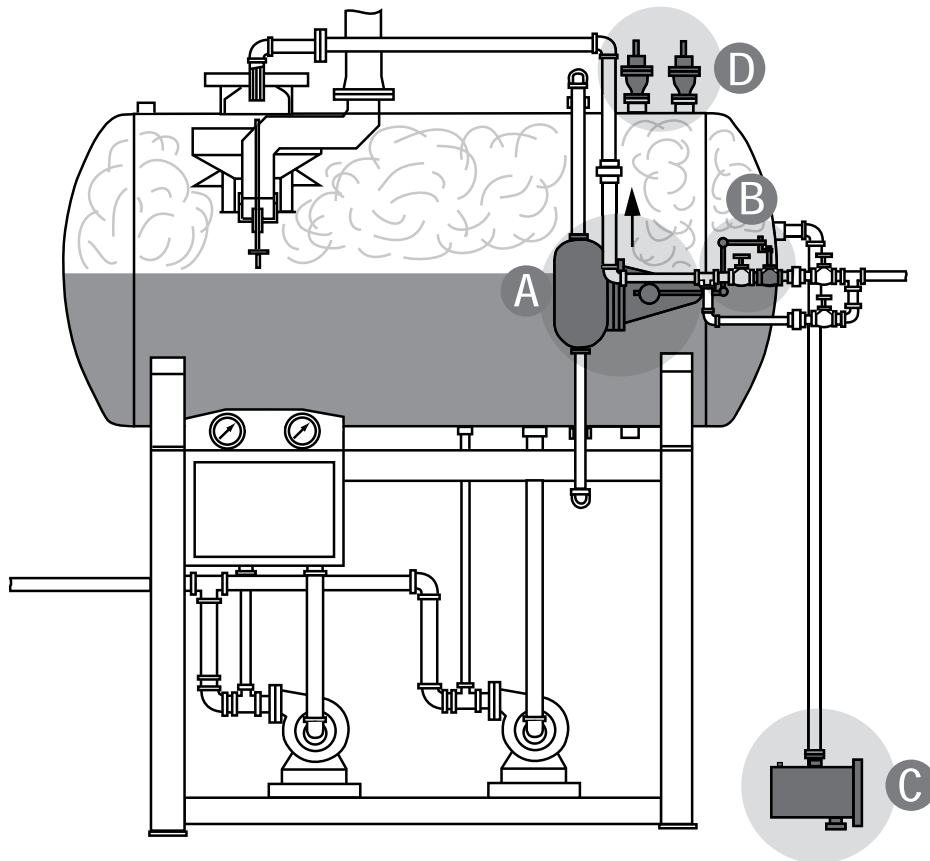

The following is a typical example of a tank filling/deaerator application using properly sized, selected, and maintained Warren Controls Level Controls. Demand for water reduces the liquid level in the tank. The [A] **377 Float Cage** opens the [B] **322L or 326L Lever Valve** to supply intake water to the tank. When the water reaches the desired level the float cage closes the lever valve to accurately maintain the liquid at the desired level. Deaerators, tanks with steam blankets, produce additional liquid as the steam condenses. The [C] **313 Overflow Trap** traps and relieves this condensate through its internal pilot without the steam blanket escaping. Overflow can occur if the water entering the tank exceeds its capacity. The 313 Overflow Trap relieves the overflow through its internal single seated main stage valve. Falling liquid levels and condensing steam can cause a vacuum that can damage the tank. The [D] **200 Vacuum Breaker** opens to admit outside air to relieve the vacuum in the tank. Warren Controls Level Controls are also used on boiler make-up water tanks and many other storage tank applications.

OPERATION — 377 FLOAT CAGE AND 326L OR 322L LEVER VALVE

- A rising or falling liquid level in a tank raises or lowers the float ball in the 377 Float Cage. This motion is converted to force through the rotation of the float rod and lever arm (lever) about the float shaft assembly. The force is transmitted through the turnbuckle assembly to the lever actuator of a 326L or 322L Lever Valve where it is used to open or close the valve. Fully immersed in water the float can exert approximately 150 inch-pounds of torque onto the float arm shaft. The maximum rotation of the float arm shaft is 23°.

INSTALLATION — 377 FLOAT CAGE AND 326L OR 322L LEVER VALVE

- To determine which lever valve you have locate the part number (configuration) on the factory serial number label (See [Information Present on 326L Lever Valves](#) section or [Information Present on 322L Lever Valves](#) section for location of important information on valve). Then see [326L Lever Valve Specification](#) section or [322L Lever Valve Specification](#) section to determine the performance and physical characteristics of the valve (configuration). See the [377 Float Cage Specification](#) section to determine the performance and physical characteristics of the 377 Float Cage.
- Be sure that the flow medium, pressure, and temperature will not exceed the limits of the 377 Float Cage. Information can be found in the product specifications (See [377 Float Cage Specification](#) section).
- Be sure that the flow medium, pressure, and temperature will not exceed the limits of the 326L or 322L Lever Valve. Information can be found in the product specifications (See [326L Lever Valve Specification](#) section or [322L Lever Valve Specification](#) section) and on the flow diagram plate regarding these limits (See [Information Present on 326L Lever Valves](#) section for location of important information on valve).
- Eliminate vibration in piping. 377 Float Cages and 326L or 322L Lever Valves are not suitable in installations where vibration exists.
- Follow good piping practices. Install a bypass around the 326L or 322L Lever Valve. Install stop valves in the inlet and outlet piping to provide a means to isolate the lever valve.
- A straight run of pipe is recommended for 10 pipe diameters upstream of the 326L or 322L Lever Valve and 20 pipe diameters downstream of the 326L or 322L Lever Valve.
- Protect 326L or 322L Lever Valve and downstream equipment with a self-cleaning strainer.
- Install gauges in inlet and outlet piping of 326L or 322L Lever Valve to provide means for checking adjustment and operation.
- Before installing, be sure the 377 Float Cage, 326L or 322L Lever Valve and piping are clean inside and free of scale, chips, welding spatter, and foreign material. Thoroughly blow out or flush pipe lines.
- Pipes must be aligned squarely with the 377 Float Cage and 326L or 322L Lever Valve at each connection.
- If the lever valve has screwed ends, do not apply pipe dope to the threads of the valve body or to the first two threads of the pipe.
- If the lever valve has flanged ends, tighten flange bolts evenly to prevent excessive stress and the possibility of cracking.
- Do not obscure factory serial number labels with paint. If flow diagram plates or inlet markings will be covered with insulation, it is recommended the information on the plates and markings be transcribed on the outside of the insulation in the same location as the plate or marking

INSTALLATION GUIDELINES

BEFORE YOU BEGIN

The guidelines presented here are for a typical tank filling application utilizing a 377 Float Cage and a Warren Controls Lever Valve. As shown in the Typical Installation Drawings the 377 closes the Lever Valve when the water in the tank reaches the desired level. Since there are numerous possible working configurations it is necessary for you to determine where the 377 and Lever Valve will be located before you install them. The INSTALLATION GUIDELINES are presented for this purpose. Please read all guidelines thoroughly before you begin

RISING LEVER OPENS VALVE DIAGRAM

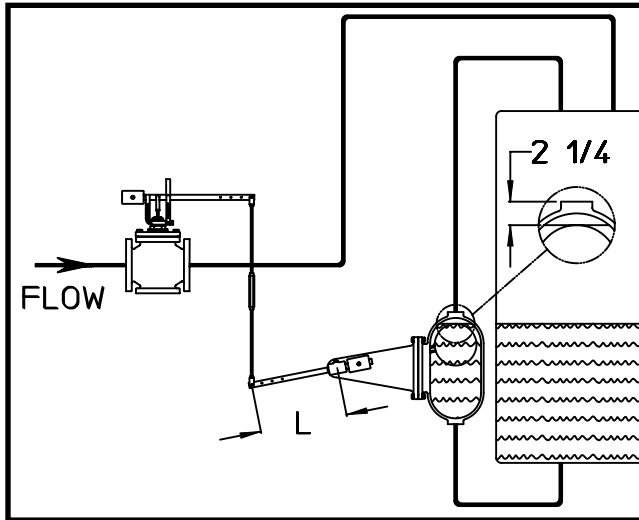

RISING LEVER CLOSES VALVE DIAGRAM

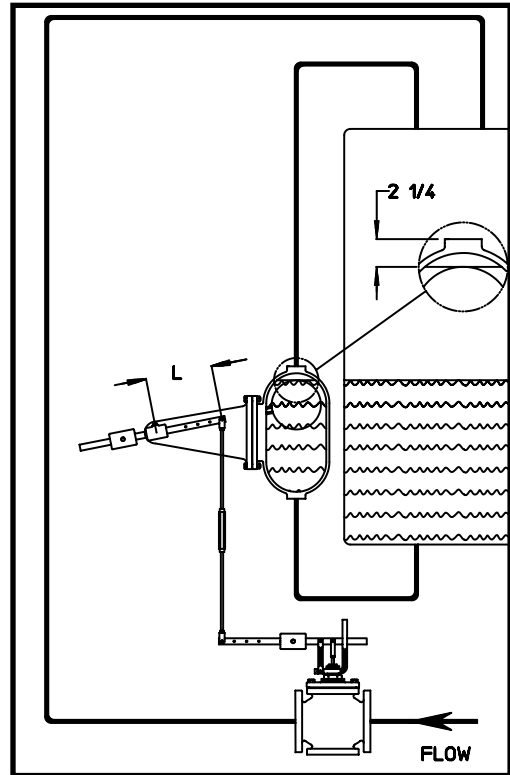

TURNBUCKLE CONNECTING HOLE DIAGRAM

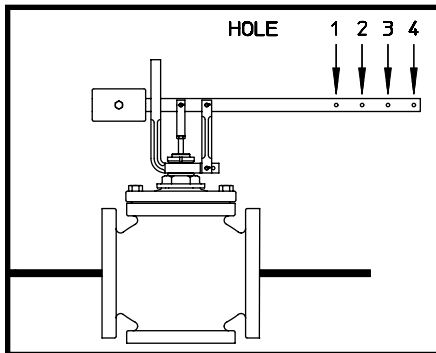

DIMENSION L - RISING LEVER OPENS VALVE

VALVE	HOLE 1	HOLE 2	HOLE 3	HOLE 4
1/2, 3/4 & 1 IN 326L	9	10-1/4	11-3/4	13-1/4
1-1/4 & 1-1/2 IN 326L	13	15-1/4	17-1/2	19-3/4
2 IN 326L	16	18-1/2	21-1/4	NA
1-1/2 & 2 IN 322L	7-1/2	8-3/4	10	11-1/4
2-1/2 & 3 IN 322L	11-1/4	13-1/4	15	17

DIMENSION L - RISING LEVER CLOSES VALVE

VALVE	HOLE 1	HOLE 2	HOLE 3	HOLE 4
1/2, 3/4 & 1 IN 326L	7-1/2	9	10-1/4	11-3/4
1-1/4 & 1-1/2 IN 326L	11	13	15-1/4	17-1/2
2 IN 326L	13-1/4	16	18-1/2	21-1/4
1-1/2 & 2 IN 322L	6-1/4	7-1/2	8-3/4	10
2-1/2 & 3 IN 322L	9-1/2	11-1/4	13-1/4	15

The 377 when installed according to these guidelines will provide a maximum water level in the tank that is 2-1/4 inches below the top of the 377. The 377 Float Cage must be installed with the axis through the 1-1/2 NPT pipe connections oriented vertically. The 326L or 322L Lever Valve is located above the 377 in rising lever opens valve applications, and below the 377 in rising lever closes valve applications. The lever valve must be installed with the fluid flowing in the correct direction. For proper operation in all applications, lever valves must be piped according to the corresponding flow arrows, or inlet markings present on each valve (See [Information Present on 326L Lever Valves](#) section or [Information Present on 322L Lever Valves](#) section for location of important information on valve). The lever valve must be installed in the vertical position with the stem pointing upward. When the maximum desired water level in the tank is reached the 377 closes the lever valve stopping the flow of water into the tank. When the lever valve is closed its lever is horizontal, the turnbuckle is vertical, the end of the 377 lever connected to the turnbuckle is at its lowest point in rising lever opens valve applications and at its highest point in rising lever closes valve applications. Clearance must be allowed for each turnbuckle connection and lever rotation. There are four possible turnbuckle connecting holes on the lever.

INSTALLATION GUIDELINES CONTINUED

Corresponding turnbuckle connections on the 377 lever are designated by the dimension "L". Dimension "L" is the distance in inches from the center of the rocker arm to the point where the turnbuckle connects to the 377 lever. (See diagrams and tables) The 377 lever may be moved in the rocker arm if the hole for the turnbuckle connection is not present at dimension "L". To move the 377 lever loosen the lever capscrew and slide the lever until a hole is in the correct location. Finally to facilitate the turnbuckle connection the lever valve lever may be rotated 360° around the valve stem. To rotate the lever loosen the yoke locknut, lift the lever slightly, and turn the lever to the desired position. Tighten the locknut to hold the lever in position. The turnbuckle must then be adjusted so the clevises line up with the levers.

BEFORE MOUNTING THE LEVER VALVE AND 377

Before mounting the Lever Valve and 377 the water level in the tank must be at least 19 inches below the maximum desired level. Do not apply water pressure to the Lever Valve inlet until you are ready to test it.

MOUNT THE 377

Mount the 377 according to the INSTALLATION GUIDELINES..

MOUNT THE LEVER VALVE

Mount the 326L or 322L Lever Valve according to the INSTALLATION GUIDELINES.

CONNECT THE TURNBUCKLE

Remove the weights from the levers. Move the lever valve lever full up and down to break the packing friction so the lever moves smoothly. Connect the turnbuckle to the correct hole on the lever valve lever. Push the end of the 377 lever farthest away from the float ball down until you hear the float ball hit the top of the 377. With the lever valve lever down as far as it will go (horizontal) for rising lever opens valve applications or up as far as it will go (horizontal) for rising lever closes valve applications adjust the turnbuckle length and connect the turnbuckle to the 377 lever at the correct dimension "L". Shorten the turnbuckle so the float ball just misses hitting the top of the 377 (you do not hear it hit the top). Make sure that the levers and turnbuckle move freely without binding or locking up then tighten the turnbuckle jamnuts.

POSITION THE WEIGHTS

Position the weights as necessary on the levers to balance the assembly. Readjust the weights until the lever valve lever just moves on its own from horizontal to full up for rising lever opens valve applications or from horizontal to full down for rising lever closes valve applications. Tighten the weight capscrews to hold the weights in position. (You may only need one weight)

TEST THE LEVER VALVE AND 377

Apply water pressure to the lever valve inlet. Water should pass through the Lever Valve and enter the tank. The water level in the tank should rise to the maximum desired level then the 377 should close the lever valve stopping the flow of water into the tank.

MAINTENANCE — 377 FLOAT CAGE AND 326L OR 322L LEVER VALVE

- 377 Float Cages for the most part are maintenance free when chosen properly for the application. Maintain the fluid pressure and temperature within the limits of the 377 Float Cage (See [377 Float Cage Specification](#) section for additional details).
- 326L and 322L Lever Valves for the most part are maintenance free when sized and chosen properly for the application. Maintain the fluid pressure, temperature, flow, and shut-off differential pressure within the limits of the valve (See [Information Present on 326L Lever Valves](#) section or [Information Present on 322L Lever Valves](#) section for location of important information on valve and [326L Lever Valve Specification](#) section or [322L Lever Valve Specification](#) section for additional details).
- 326L and 322L Lever Valves are equipped with self-adjusting packing; no adjustment is required. The valve stem must be kept free of debris, deposits, dirt, dust, and scratches or the packing parts may be damaged resulting in a packing leak.
- In water or water and glycol applications, good water quality must be maintained or the service life of the 377 Float Cage and 326L or 322L Lever Valve may be reduced (See [Warren Controls Water Quality Guidelines](#) for details).

OVERHAUL — 377 FLOAT CAGE, AND 326L OR 322L LEVER VALVE

- Rebuilding of the 377 Float Cage and 326L or 322L Lever Valve should not be necessary under normal operating conditions. Should the 377 Float Cage and 326L or 322L Lever Valve become worn or defective, parts kits are available. See Parts/ Overhaul.

INFORMATION PRESENT ON 377 FLOAT CAGE

There is information present on each float cage ranging in importance from the part number and serial number to casting numbers. This information is important for identifying the float cage, installing it correctly, and obtaining parts. **An example of the current factory serial number label used on 377 float cages is shown here.** The accompanying table identifies the information present and where to find it on the float cage. There may also be other casting numbers and foundry marks present that do not provide useful information. Customer specific tagging may also present. The labels or plates used, and information present, on Warren Controls other product lines or older float cages may be different, contact the factory for details.

FACTORY SERIAL NUMBER LABEL



INFORMATION PRESENT ON 377 FLOAT CAGE

PART NUMBER & SERIAL NUMBER			
INFORMATION	SYMBOL(S)	LOCATION	NOTES
Part number	P/N	On float box body	* On Factory Serial Number Label attached to float box body.
Serial Number	SERIAL NO.	On float box body and float box neck	* On Factory Serial Number Label attached to float box body. * Sales order number only stamped on float box neck flange.* * Number stamped using approximately 1/8 inch tall characters

INFORMATION PRESENT ON 326L LEVER VALVES

There is information present on each lever valve ranging in importance from the part number and serial number to casting numbers. This information is important for identifying the valve, installing it correctly, and obtaining parts. **Examples of the current factory serial number label used on bronze and stainless steel ½ thru 2 inch 326L Lever Valves and the flow diagram plate used on stainless steel ½ thru 2 inch 326L Lever Valves are shown here.** The accompanying table identifies the information present and where to find it on the lever valve. There may also be other casting numbers and foundry marks present that do not provide useful information. Customer specific tagging may also present. The labels or plates used, and information present, on Warren Controls other product lines or older valves may be different, contact the factory for details.

FACTORY SERIAL NUMBER LABEL



FLOW DIAGRAM PLATE

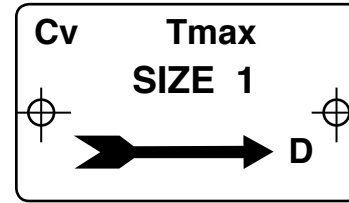

Flow Diagram Plate
For 326L
Stainless Steel Valves
Size 1/2 thru 1
(Size 1 Shown)

INFORMATION PRESENT ON 326L LEVER VALVES BRONZE OR STAINLESS STEEL 1/2 THRU 2 INCH

PART NUMBER & SERIAL NUMBER			
INFORMATION	SYMBOL(S)	LOCATION	NOTES
Part number	P/N	On actuator	• On Factory Serial Number Label attached to actuator.
Serial Number	SERIAL NO.	On actuator and valve body	• On Factory Serial Number Label attached to actuator. • Sales order number only stamped on valve body end connection.* * Number stamped using approximately 1/8 inch tall characters
FLOW DIRECTION			
INFORMATION	SYMBOL(S)	LOCATION	NOTES
Flow direction through valve		On valve body	• On Flow Diagram Plate attached to mounting boss on valve body between the end connections (S/S valves 1/2 thru 1 inch). • Arrow cast on valve body between the end connections (2-way S/S 1-1/4 - 2 inch).
Inlet location	INLET	On valve body	• Stamped on valve body inlet end connection (2-way bronze valves 1/2 thru 2 inch & S/S valves 1-1/4 thru 2 inch).
VALVE ATTRIBUTES			
INFORMATION	SYMBOL(S)	LOCATION	NOTES
Maximum temperature rating of valve body	Tmax	On valve body	• On Flow Diagram Plate attached to mounting boss on valve body between the end connections (S/S valves 1/2 thru 1 inch).
Trim Cv (Flow coefficient)	Cv	On valve body	• On Flow Diagram Plate attached to mounting boss on valve body between the end connections (S/S valves 1/2 thru 1 inch).
Valve Size	SIZE	On valve body	• On Flow Diagram Plate attached to mounting boss on valve body between the end connections (S/S valves 1/2 thru 1 inch).
Valve Body Material		On valve body	• If CF8M is cast on the valve the valve body material is 316 stainless steel.

INFORMATION PRESENT ON 322L LEVER VALVES

There is information present on each lever valve ranging in importance from the part number and serial number to the color of the paint and casting numbers. This information is important for identifying the valve, installing it correctly, and obtaining parts. **An example of the current factory serial number label used on 1-1/2 thru 3 inch 322L Lever Valves is shown here.** The accompanying table identifies the information present and where to find it on the lever valve. There may also be other casting numbers and foundry marks present that do not provide useful information. Customer specific tagging may also present. The labels or plates used, and information present, on Warren Controls other product lines or older valves may be different, contact the factory for details..

FACTORY SERIAL NUMBER LABEL

Warren Controls, Inc.
2600 Emrick Blvd
 Bethlehem, PA 18020-8010
 PH: (610) 317-0800
 FAX: (610) 317-2989
 www.warrencontrols.com



LEVER VALVE
SERIAL NO.
P/N
DO NOT REMOVE TAG

INFORMATION PRESENT ON 322L LEVER VALVES IRON 1-1/2 THRU 3 INCH

PART NUMBER & SERIAL NUMBER			
INFORMATION	SYMBOL(S)	LOCATION	NOTES
Part number	P/N	On actuator	• On Factory Serial Number Label attached to actuator.
Serial Number	SERIAL NO.	On actuator and valve body	• On Factory Serial Number Label attached to actuator. • Sales order number only stamped on top of valve body top cover or top of valve body* * Number stamped using approximately 1/8 inch tall characters
FLOW DIRECTION			
INFORMATION	SYMBOL(S)	LOCATION	NOTES
Flow direction through valve		On valve body	• Arrow cast on valve body between the end connections.
VALVE ATTRIBUTES			
INFORMATION	SYMBOL(S)	LOCATION	NOTES
Valve Body Material		On valve body	• If the factory applied paint is black the valve body material is iron.

377 FLOAT CAGE SPECIFICATIONS

377	Part Number
Standard 377	0377XXXXX000
377 with sight glass tappings	0377XXXXX002
377 with sight glass assembly	0377XXXXX003
Extra Turnbuckle Sections	
2 Ft Section	B3100033
3 Ft Section	B3100034

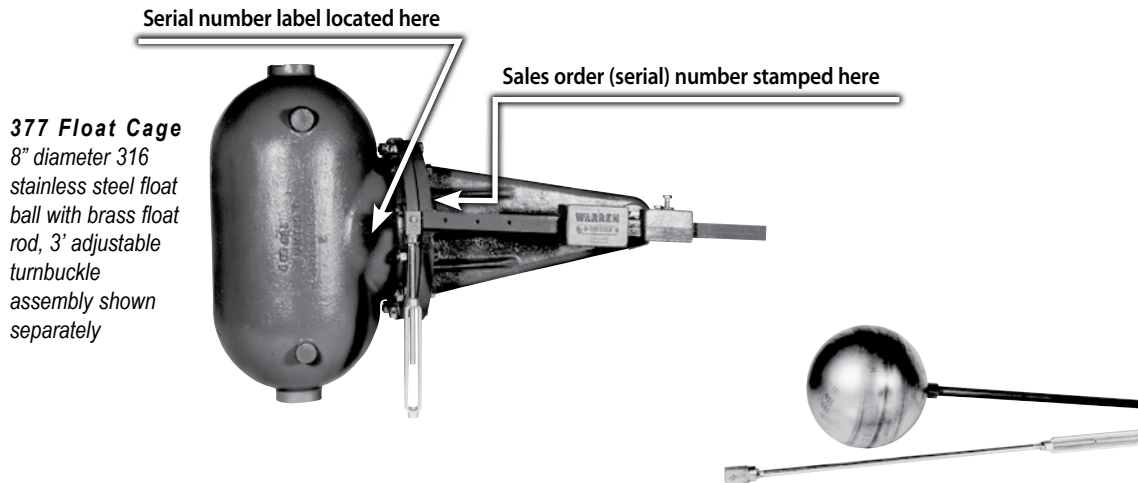

377 Float Cage
8" diameter 316 stainless steel float ball with brass float rod, 3' adjustable turnbuckle assembly shown separately

APPLICATION:

The 377 Float Cage opens a 322L or 326L Lever Valve to supply intake water to a tank. When the water reaches the desired level the Float Cage closes the Lever Valve to accurately maintain the liquid at the desired level. Buoyancy of its internal float ball provides the force to actuate the lever valve.

FEATURES:

Cast iron body, 1-1/2" NPT connections, 316 stainless steel float ball, epr o-ring, steel lever and turnbuckle assembly.

- Lever and turnbuckle assembly are adjustable to ease installation and connection to lever valve.
- Standard turnbuckle is adjustable from 30 to 36 inches in length.
- Extra turnbuckle sections are available for a combined length up to 10 feet.
- Mounting bosses present on body can be provided with 1/2" NPT pipe tappings for optional sight glass assembly.
- Optional sight glass assembly is available complete with brass ball check, shut-off valves, and drain valves.

PRESSURE — TEMPERATURE RATINGS:

Body 125lb rated cast iron

APPROXIMATE SHIPPING WEIGHT:

190 lb

FOR DIMENSIONS SEE DRAWINGS 03770524101

BODY PRESSURE-TEMPERATURE RATINGS: Pressure Ratings and PSIG

Temperature	Iron Body
+32 to 100°F	175 PSIG
150°F	175 PSIG
175°F	170 PSIG
200°F	165 PSIG
225°F	155 PSIG
250°F	150 PSIG
275°F	145 PSIG
300°F	140 PSIG

LEVER VALVES SPECIFICATIONS

326L	Part Number		
Description	Size	End Connection	Part Number
BRONZE BODY WITH EQ% ST. STL.TRIM	1/2	NPT	VA2604AC-L000
	3/4	NPT	VA2605AC-L000
	1	NPT	VA2606AC-L000
	1-1/4	NPT	VA2607AC-L000
	1-1/2	NPT	VA2608AC-L000
ST.STL.BODY WITH EQ% ST. STL.TRIM	2	NPT	VA2609AC-L000
	1/2	NPT	VA2604EC-L000
	3/4	NPT	VA2605EC-L000
	1	NPT	VA2606EC-L000
	1-1/2	NPT	VA2608EC-L000
	2	NPT	VA2609EC-L000

322L	Part Number		
Description	Size	End Connection	Part Number
DOUBLE SEAT IRON BODY WITH EQ% ST. STL. TRIM	1-1/2	NPT	VA2208BC-L000
	2	NPT	VA2209BC-L000
DOUBLE SEAT IRON BODY WITH EQ% ST. STL. TRIM	2-1/2	125 FLG	VA2210CA-L000
	3	125 FLG	VA2211CA-L000
DOUBLE SEAT IRON BODY WITH EQ% ST. STL.TRIM	2-1/2	125 FLG	VA2210CC-L000
	3	125 FLG	VA2211CC-L000

326L LEVER VALVE

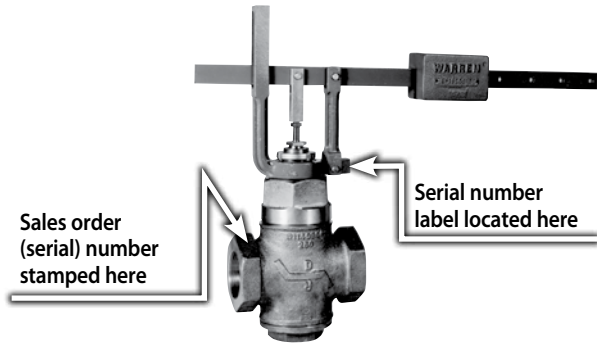

2" Bronze 326L

APPLICATION:

A 377 Float Cage opens the 326L Lever Valve to supply intake water to a tank. When the water reaches the desired level the Float Cage closes the Lever Valve to accurately maintain the liquid at the desired level. The 326L combines a balanced, pilot operated, single seated Type 26 globe valve with a rugged lever actuator.

FEATURES:

Bronze or stainless steel body, stainless steel trim, TFE v-ring packing, epr o-ring, cast iron lever actuator, and steel lever. Sizes 1/2" through 2" with NPT connections. Lever actuator is adjustable 360° around top of valve for ease of installation and connection to float cage. Lever actuator can be reversed from rising lever opens valve to rising lever closes valve.

Cv's to 40

Shut-off pressures to 100 PSI

Nominal leakage rate 0.1% of rated capacity

FOR DIMENSIONS SEE DRAWINGS 00260521101, 00260521102 & 03000521101.

322L LEVER VALVE

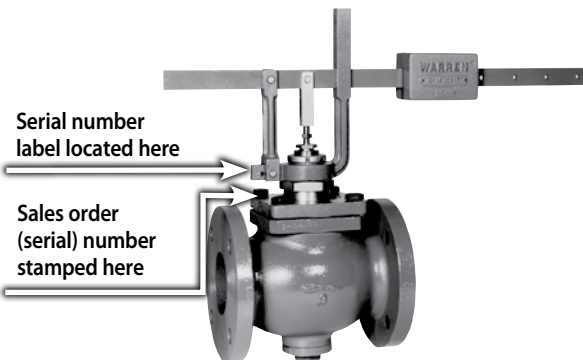

3" Iron 322L

APPLICATION:

A 377 Float Cage opens the 322L Lever Valve to supply intake water to a tank. When the water reaches the desired level the Float Cage closes the Lever Valve to accurately maintain the liquid at the desired level. The 322L combines a double seated Type 22 globe valve with a rugged lever actuator.

FEATURES:

Cast iron body, bronze trim with EPDM lip packing or stainless steel trim with TFE v-ring packing, cast iron lever actuator and steel lever.

Sizes 1-1/2" and 2" with NPT connections,

2-1/2" and 3" with 125FLG

Lever actuator is adjustable 360° around top of valve for ease of installation and connection to float cage.

Lever actuator can be reversed from rising lever opens valve to rising lever closes valve.

Cv's to 100

Shut-off pressures to 100PSI

Nominal leakage rate 0.5% of rated capacity

FOR DIMENSIONS SEE DRAWINGS 00220521101 & 03000521101.

LEVER VALVES SPECIFICATIONS

PRESSURE-TEMPERATURE:

Temp (F)	Bronze & Iron Thd	Iron 125 Flg	St Steel Thd
+32 to 100F	400 PSIG	175 PSIG	400 PSIG

What's Available

Features	326L			322L	
	Size (IN)			Size (IN)	
	1/2,3/4,1	1-1/4	1-1/2,2	1-1/2,2	2-1/2,3
Trim Material	BRONZE				●
	ST STL	●	●	●	●
Body Material & End Connection	BRONZE THREADED (NPT)	●	●	●	
	IRON THREADED (NPT)			●	
	ST STL THREADED (NPT)	●		●	
	IRON 125FLG				●
Pkg.	TFE V-RING (S/S Trim)	●	●	●	●
	EPDM (Brz Trim)				●

SHUT-OFFS:

326L/322L	Maximum Shut-Off (PSID) Using 377 Float Cage							
	Valve Size (IN)							
Valve	1/2	3/4	1	1-1/4	1-1/2	2	2-1/2	3
326L	100	100	100	100	100	100	-	-
322L	-	-	-	-	100	100	80	60

● STANDARD

APPROXIMATE SHIPPING WEIGHTS:

326L/322L	Weights (LB)							
	Valve Size (IN)							
Valve	1/2	3/4	1	1-1/4	1-1/2	2	2-1/2	3
326L	24	24	25	32	32	37	-	-
322L	-	-	-	-	33	33	50	60

FLOW COEFFICIENTS Cv:

326L/322L	Cv							
	Valve Size (IN)							
Valve	1/2	3/4	1	1-1/4	1-1/2	2	2-1/2	3
326L	6.9	7.7	10	19	25	40	-	-
322L	-	-	-	-	30	42	70	100

FLOW CAPACITIES:

326L	GPM					
	Valve Size (IN)					
DP (PSI)	1/2	3/4	1	1-1/4	1-1/2	2
5	15	17	22	42	56	89
10	22	24	32	60	79	126
15	27	30	39	74	97	155
20	31	34	45	85	112	179
25	35	39	50	95	125	200
30	38	42	55	104	137	219
35	41	46	59	112	148	237
40	44	49	63	120	158	253
45	46	52	67	127	168	268
50	49	54	71	134	177	283

326L	GPM			
	Valve Size (IN)			
DP (PSI)	1-1/2	2	2-1/2	3
5	67	94	157	224
10	95	133	221	316
15	116	163	271	387
20	134	188	313	447
25	150	210	350	500
30	164	230	383	548
35	177	248	414	592
40	190	266	443	632
45	201	282	470	671
50	212	297	495	707

377 FLOAT CAGE PARTS / OVERHAUL

Damaged or worn parts can decrease performance and shorten the life of the float cage.

A damaged **float ball and/or float rod** can result in poor control and poor shut-off of the attached lever valve.

A damaged or worn **float arm shaft with elbow** can result in poor control and poor shut-off of the attached lever valve, and can also cause damage to the bonnet and o-ring.

A damaged or missing **e-ring** can result in damage to the float rod, float arm shaft, o-ring, and linkage.

A damaged or worn **bonnet** can result in poor control and poor shut-off of the attached lever valve, and can also cause damage to the float shaft and o-ring.

A damaged or worn **o-ring** can result in poor control and poor shut-off of the attached lever valve, and can also cause damage to the bonnet and float shaft.

A damaged or worn **gasket or o-ring** can cause external leakage resulting in damage to surrounding equipment.

A damaged **lever arm or turn buckle assembly** can result in poor control and poor shut-off of the attached lever valve.

Two different parts kits are available. The float ball kit allows for the float ball to be replaced. The replacement neck assembly kit allows for the entire neck assembly including the float rod, float arm shaft, and bonnet, minus the float ball, to be replaced. Individual parts are also available. **Please provide serial number to get the correct kit or individual part numbers.**

PACKING ADJUSTMENT

326L and 322L Lever Valves have self-adjusting packing and require no external adjustment. 326L and 322L Lever Valves with stainless steel trim have TFE V-ring Packing. 322L Lever Valves with bronze trim have EPDM Lip Packing. If the valve has self-adjusting packing and a packing leak is observed replace the packing and if necessary the stem and plug assembly.

326L AND 322L LEVER VALVE PARTS/ OVERHAUL

Damaged or worn parts can decrease performance and shorten valve life.

Damaged or worn packing parts including as applicable the packing, bearings, spring, and other bonnet parts can cause a packing leak resulting in damage to the actuator and surrounding equipment. Damaged or worn packing parts can also cause increased hysteresis resulting in poor control.

Damaged or worn trim parts including as applicable the plug, stem, seat ring(s), piston, pilot retainer, and o-ring can cause increased hysteresis, poor control, excessive internal leakage, and poor shut-off. Damaged or worn trim parts can also cause damage to the packing parts resulting in a packing leak.

Damaged or worn body gaskets can cause external leakage resulting in damage to the actuator, accessories, and surrounding equipment.

Should parts become worn or damaged, parts kits are available. Repack Kits are available to replace the packing. Repack/Inspection Kits are available to allow the valve to be opened for inspection of its internal parts. Rebuild/Repack Kits are available to completely rebuild/overhaul the valve. Parts kits come with complete step-by-step instructions. Each kit has its own part number. **Please provide the valve's serial number to ensure getting the correct kit part number and correct parts.**

377 FLOAT CAGE PARTS KITS (PROVIDE FLOAT CAGE SERIAL NUMBER TO GET KIT PART NUMBERS)

Two different parts kits are available. The float ball kit allows for the float ball to be replaced. The replacement neck assembly kit allows for the entire neck assembly including the float rod, float arm shaft, and bonnet, minus the float ball, to be replaced.

377 FLOAT BALL KIT - SEE DWG 03770524101					
ITEM	QTY	DESCRIPTION	ITEM	QTY	DESCRIPTION
1	1	FLOAT BALL	3	1	GASKET

377 REPLACEMENT NECK ASSEMBLY KIT - SEE DWG 03770524101					
ITEM	QTY	DESCRIPTION	ITEM	QTY	DESCRIPTION
3	1	GASKET	18	1	BONNET
8	1	FLOAT BOX NECK	19	1	O-RING
16	1	FLAT ARM SHAFT W/ BRAZED ELBOW	20	1	FLOAT ROD
17	1	E-RING			

26 VALVE PARTS KITS (PROVIDE VALVE SERIAL NUMBER TO GET KIT PART NUMBERS)

Three different kinds of parts kits are available. The repack kit allows a valve to be repacked. The repack/inspection kit allows a valve to be opened for inspection of internal parts and then repacked. The rebuild/repack kit allows a valve to be overhauled and then repacked.

REPACK KIT - FOR 26 BRONZE VALVE WITH TEFLON V-RING PACKING - SEE DWG C3769950					
ITEM	QTY	DESCRIPTION	ITEM	QTY	DESCRIPTION
2	1	RETAINER BEARING	7	1	PACKING SPRING
3	1	PACKING RETAINER	8	1	O-RING RETAINER
5	1	V-RING PACKING SET	9	1	O-RING
6	1	MALE ADAPTER	12	1	TUBE STEM LUBE

REPACK KIT - FOR 26 ST STL VALVE WITH TEFLON V-RING PACKING - SEE DWG C3760953					
ITEM	QTY	DESCRIPTION	ITEM	QTY	DESCRIPTION
3	1	O-RING	7	1	V-RING PACKING SET
4	1	O-RING RETAINER	9	1	RETAINER BEARING
5	1	PACKING SPRING	10	1	PACKING RETAINER
6	1	MALE ADAPTER	12	1	TUBE STEM LUBE

REPACK/ INSPECTION KIT - FOR 26 BRONZE VALVE WITH TEFLON V-RING PACKING					
ITEM	QTY	DESCRIPTION	ITEM	QTY	DESCRIPTION
	1	TUBE PERMATEx #2		1	REPACK KIT

26 VALVE PARTS KITS CONTINUED

REPACK/ INSPECTION KIT - FOR 26 BRONZE VALVE WITH TEFLON V-RING PACKING

ITEM	QTY	DESCRIPTION	ITEM	QTY	DESCRIPTION
	1	TUBE PST SEALANT		1	REPACK KIT

REBUILD/ REPACK KIT - FOR 26 BRONZE VALVE WITH TEFLON V-RING PACKING - SEE DWG 00260521101

ITEM	QTY	DESCRIPTION	ITEM	QTY	DESCRIPTION
1	1	VALVE STEM	7	1	SEAT RING
3	1	PILOT RETAINER		1	TUBE PERMATEX #2
4	1	O-RING		1	TUBE O-RING LUBE
5	1	GROOVE PIN		1	ADDITIONAL BONNET SUBASSEMBLY PARTS (SEE TABLE)
6	1	PISTON & PLUG		1	REPACK KIT

REBUILD/ REPACK KIT - FOR 26 ST STL VALVE WITH TEFLON V-RING PACKING - SEE DWG 00260521102

ITEM	QTY	DESCRIPTION	ITEM	QTY	DESCRIPTION
1	1	VALVE STEM	7	1	SEAT RING
3	1	PILOT RETAINER		1	TUBE PST SEALANT
4	1	O-RING		1	TUBE O-RING LUBE
5	1	GROOVE PIN		1	ADDITIONAL BONNET SUBASSEMBLY PARTS (SEE TABLE)
6	1	PISTON & PLUG		1	REPACK KIT

ADDITIONAL BONNET SUBASSEMBLY PARTS IN REBUILD/ REPACK KIT FOR 26 BRONZE VALVE WITH TEFLON V-RING PACKING - SEE DWG C3769950

ITEM	QTY	DESCRIPTION	ITEM	QTY	DESCRIPTION
10	1	BONNET BEARING	11	1	BONNET

FOR 26 ST STL VALVE WITH TEFLON V-RING PACKING - SEE DWG C3760953

ITEM	QTY	DESCRIPTION	ITEM	QTY	DESCRIPTION
1	1	BONNET	2	1	BONNET BEARING

22 VALVE PARTS KITS (PROVIDE VALVE SERIAL NUMBER TO GET KIT PART NUMBERS)

Three different kinds of parts kits are available. The repack kit allows a valve to be repacked. The repack/inspection kits allow a valve to be opened for inspection of internal parts and then repacked. The rebuild/repack kits allow a valve to be overhauled and then repacked.

REPACK KIT - FOR 22 VALVE WITH STAINLESS STEEL TRIM AND TEFLON V-RING PACKING - SEE DWG C3769950					
ITEM	QTY	DESCRIPTION	ITEM	QTY	DESCRIPTION
2	1	RETAINER BEARING	7	1	PACKING SPRING
3	1	PACKING RETAINER	8	1	O-RING RETAINER
5	1	V-RING PACKING SET	9	1	O-RING
6	1	MALE ADAPTER	12	1	TUBE STEM LUBE

REPACK KIT - FOR 22 VALVE WITH BRONZE TRIM AND EPDM LIP PACKING - SEE DWG C3769956					
ITEM	QTY	DESCRIPTION	ITEM	QTY	DESCRIPTION
2	1	PACKING RETAINER	5	3	LIP PACKING
3	1	RETAINER BEARING	8	1	TUBE STEM LUBE

REPACK/ INSPECTION KIT - FOR 22 VALVE SIZE 1-1/2 THRU 3 INCH - SEE DWG 00220521101					
ITEM	QTY	DESCRIPTION	ITEM	QTY	DESCRIPTION
6	1	GASKET		1	REPACK KIT

REBUILD/ REPACK KIT - FOR 22 VALVE SIZE 1-1/2 THRU 3 INCH - SEE DWG 00220521101					
ITEM	QTY	DESCRIPTION	ITEM	QTY	DESCRIPTION
1	1	VALVE STEM	9	1	PLUG
3	1	TRAVEL STOP (As required)		1	TUBE PERMATEX #2
7	1	GROOVE PIN		1	ADDITIONAL BONNET SUBASSEMBLY PARTS (SEE TABLE)
6	1	GASKET		1	REPACK KIT
<i>SEAT RINGS ARE MACHINED IN VALVE AND ARE NOT AVAILABLE SEPARATELY</i>					

ADDITIONAL BONNET SUBASSEMBLY PARTS IN REBUILD/ REPACK KIT FOR 26 BRONZE VALVE WITH TEFLON V-RING PACKING - SEE DWG C3769950					
ITEM	QTY	DESCRIPTION	ITEM	QTY	DESCRIPTION
10	1	BONNET BEARING	11	1	BONNET
FOR 22 VALVE WITH BRONZE TRIM AND EPDM LIP PACKING - SEE DWG C3769956					
ITEM	QTY	DESCRIPTION	ITEM	QTY	DESCRIPTION
6	1	BONNET	7	1	BONNET BEARING

DRAWING 03770524101-1

Type 377 Float Cage

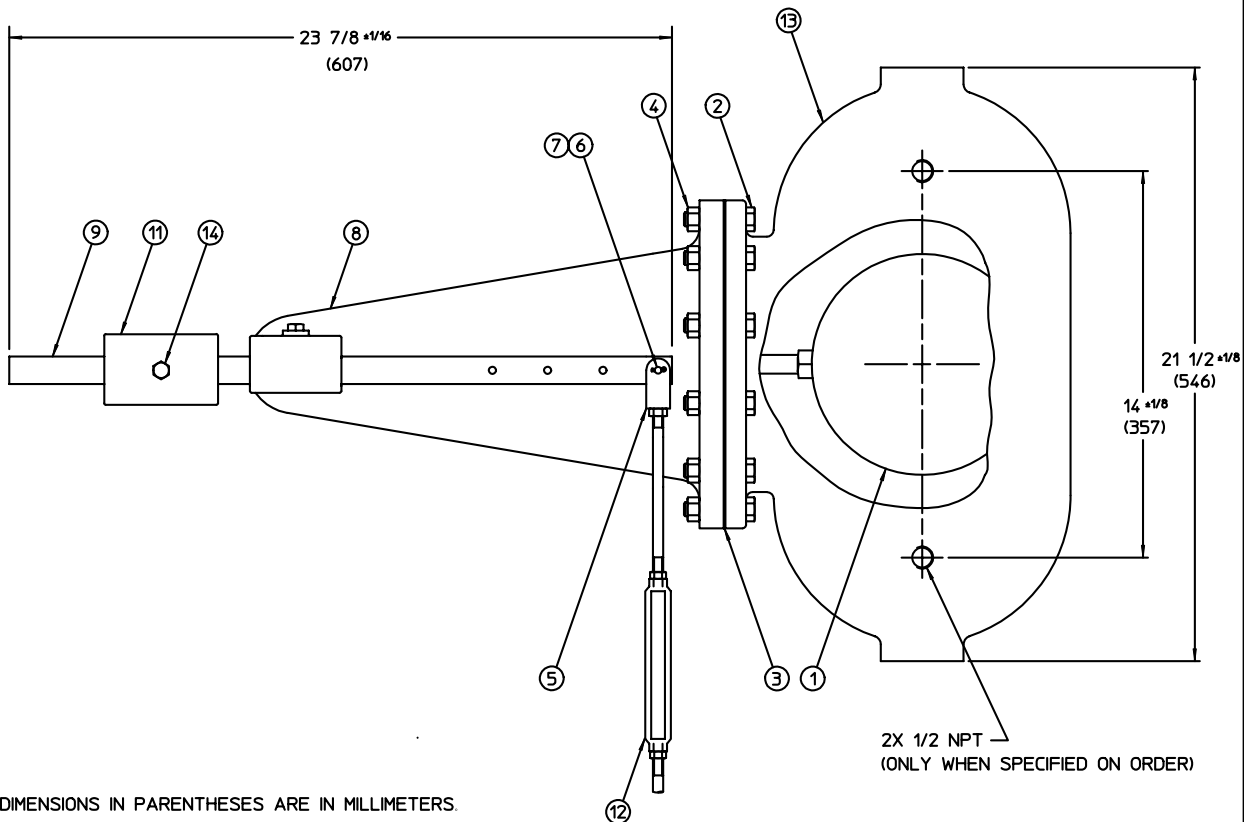
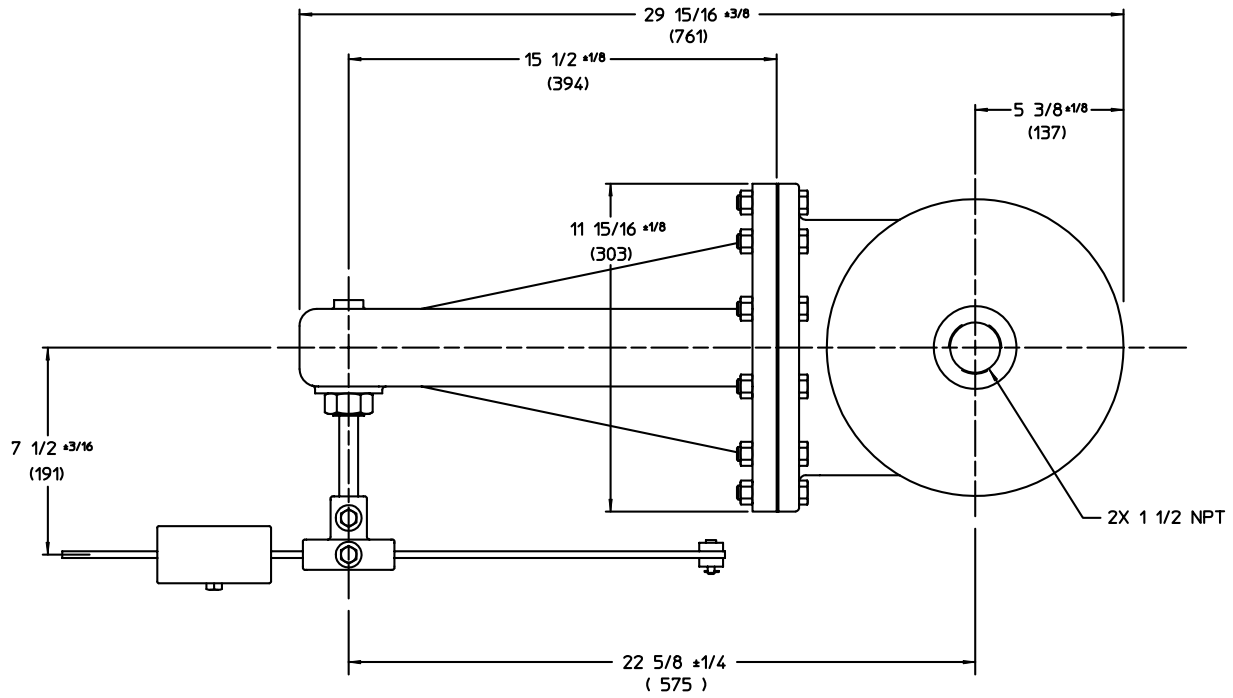

1) DIMENSIONS IN PARENTHESES ARE IN MILLIMETERS.

NOTES:

DRAWING 03770524101-2

Type 377 Float Cage

BILL OF MATERIAL					
NO.	DESCRIPTION	MATERIAL	NO.	DESCRIPTION	MATERIAL
1	FLOAT BALL	ST STL	11	WEIGHT	CAST IRON
2	CAPSCREW	STL PLTD	12	TURNBUCKLE	STL PLTD
3	GASKET	NONASBESTOS	13	FLOAT BOX BODY	CAST IRON
4	NUT	STL PLTD	14	CAPSCREW	STL PLTD
5	CLEVIS	ST STL	15	ROCKER ARM	CAST IRON
6	COTTER PIN	BRASS	16	FLOAT ARM SHAFT WITH BRAZED ELBOW	ST STL/BRONZE
7	CLEVIS PIN	BRASS	17	E RING	STL PLTD
8	FLOAT BOX NECK	CAST IRON	18	BONNET	BRASS
9	LEVER ARM	STEEL	19	O-RING	EPR
10	CAPSCREW	STL PLTD	20	FLOAT ROD	BRASS

PARTS DETAIL

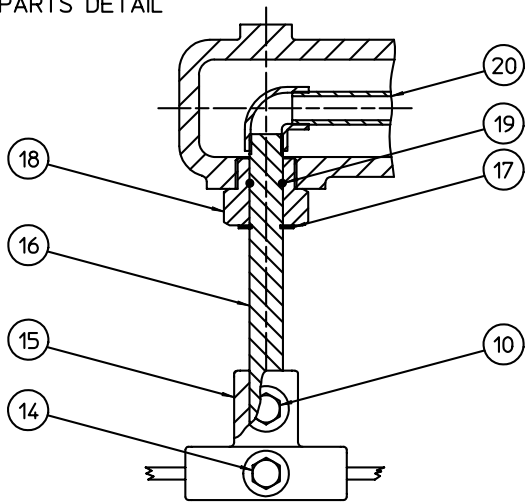

FIGURE 1

DRAWING 00260521101

Type 26 Bronze Valve Body Assembly

SIZE	A	B	C
1/2 - 1 (15-25)	4-7/8 (124)	2-5/8 (67)	3-13/16 (97)
1-1/4 - 1-1/2 (32-40)	5-3/4 (147)	3-1/8 (80)	4-3/16 (107)
2 (50)	6-1/2 (166)	3-7/16 (88)	4-3/4 (121)

ITEM	PART NOMENCLATURE
1	VALVE STEM
2	BONNET SUBASSEMBLY
3	PILOT RETAINER
4	O-RING
5	GROOVE PIN
6	PISTON & PLUG
7	SEAT RING
8	VALVE BODY
9	BOTTOM PLUG

NOTES:
DIMENSIONS IN PARENTHESES ARE IN MILLIMETERS

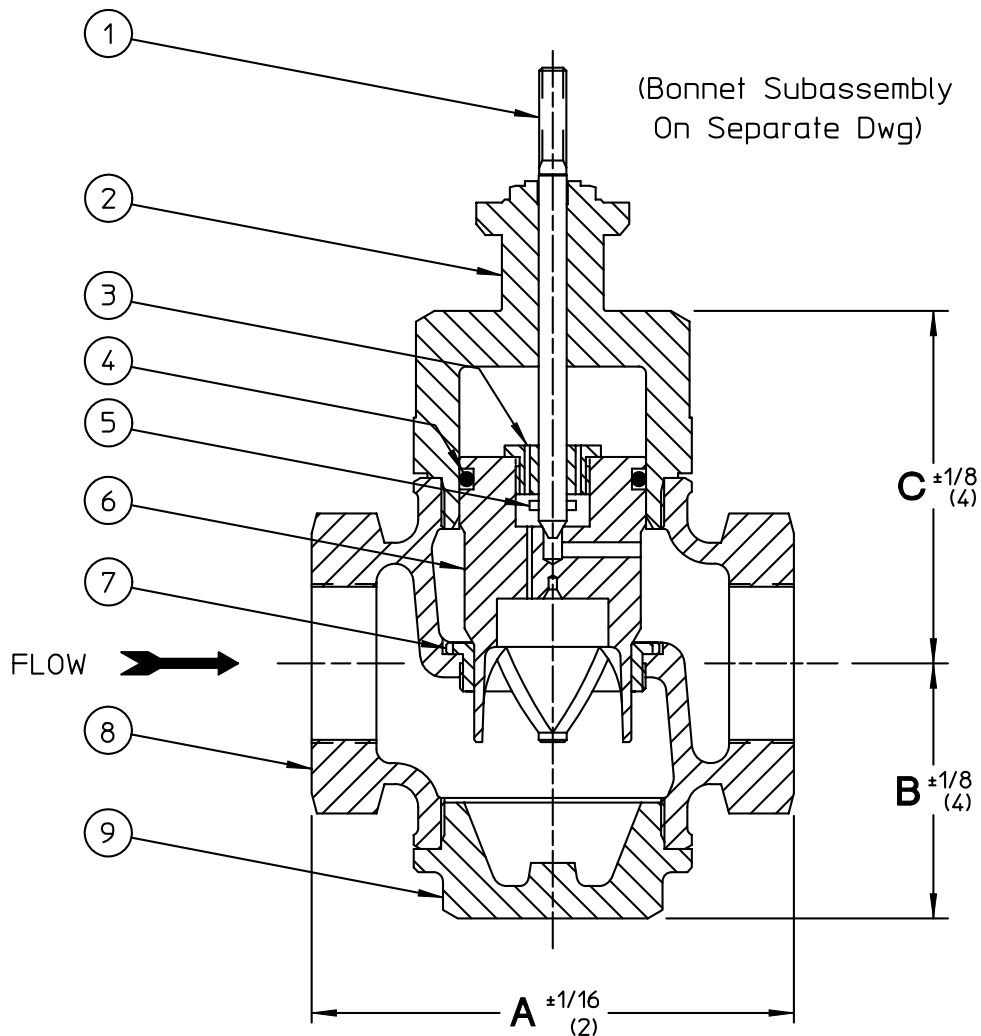

DRAWING 00260521102

Type 26 Stainless Steel Valve Body Assembly

SIZE	A		B		C	
1/2 - 1 (15-25)	5	(127)	2-13/16	(72)	3-13/16	(97)
1-1/2 (40)	6-1/8	(156)	3-3/8	(86)	4-3/16	(107)
2 (50)	6-1/2	(166)	3-11/16	(94)	4-3/4	(121)

ITEM	PART NOMENCLATURE
1	VALVE STEM
2	BONNET SUBASSEMBLY
3	PILOT RETAINER
4	O-RING
5	GROOVE PIN
6	PISTON & PLUG
7	SEAT RING
8	VALVE BODY
9	BOTTOM PLUG

NOTES:
DIMENSIONS IN PARENTHESES ARE IN MILLIMETERS

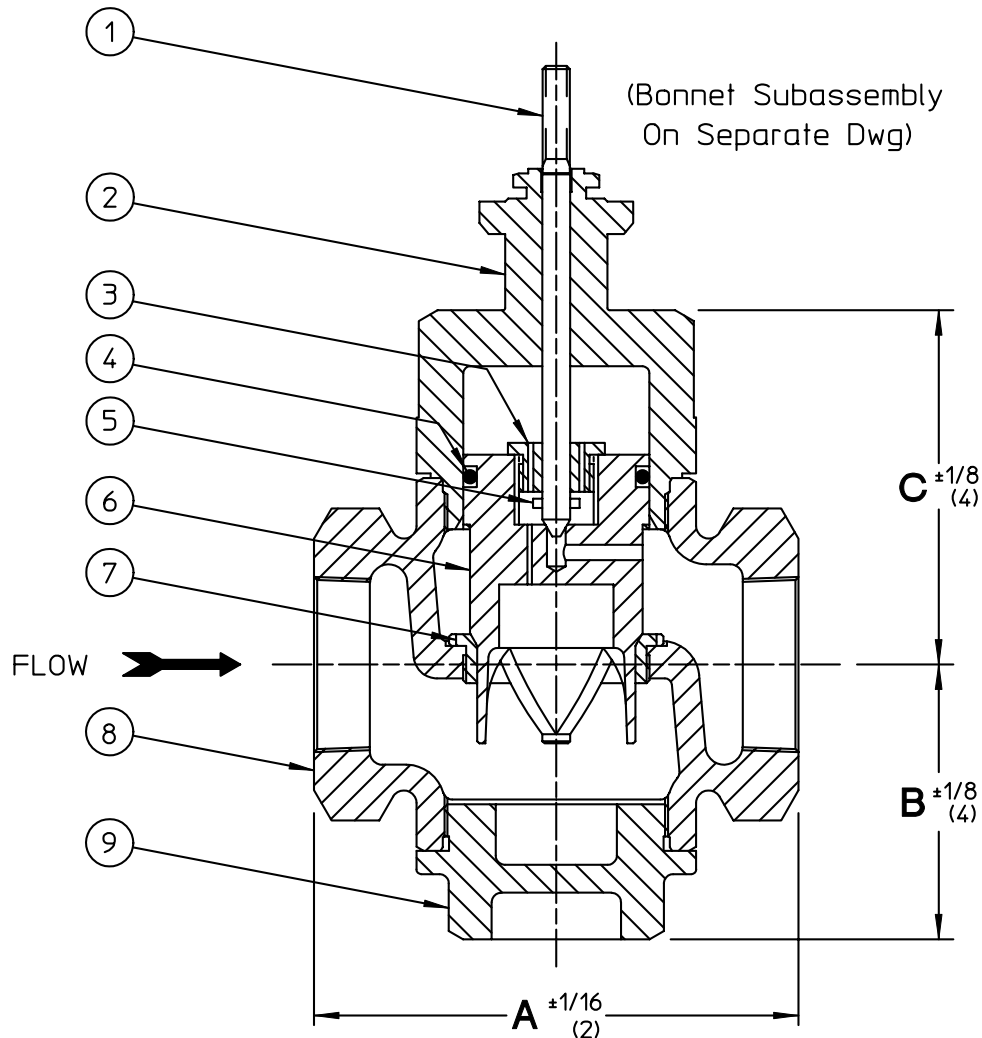

DRAWING 00220521101

Type 22 Valve Body Assembly

SIZE		A	B	C
1-1/2 (40)	250THD	7-3/8 (188)	3-3/4 (96)	4-1/2 (115)
2 (50)	250THD	7-3/8 (188)	3-3/4 (96)	4-1/2 (115)
2-1/2 (65)	125FLG	7-3/4 (197)	4 (102)	4-7/8 (124)
	250FLG	8-3/8 (213)		
3 (80)	125FLG	9 (229)	4-1/4 (108)	5-1/16 (129)
	250FLG	9-3/4 (248)		

ITEM	PART NOMENCLATURE
1	VALVE STEM
2	BONNET SUBASSEMBLY
3	TRAVEL STOP
4	COVER
5	HEX HEAD CAPSCREW
6	GASKET
7	GROOVE PIN
8	UPPER SEAT RING
9	PLUG
10	LOWER SEAT RING
11	VALVE BODY
12	BOTTOM GUIDE PLUG

NOTES:

- 1) 1-1/2 & 2 INCH TYPE 22 VALVE BODY ASSEMBLIES ARE ONLY AVAILABLE WITH NPT CONNECTIONS
- 2) DIMENSIONS IN PARENTHESES ARE IN MILLIMETERS

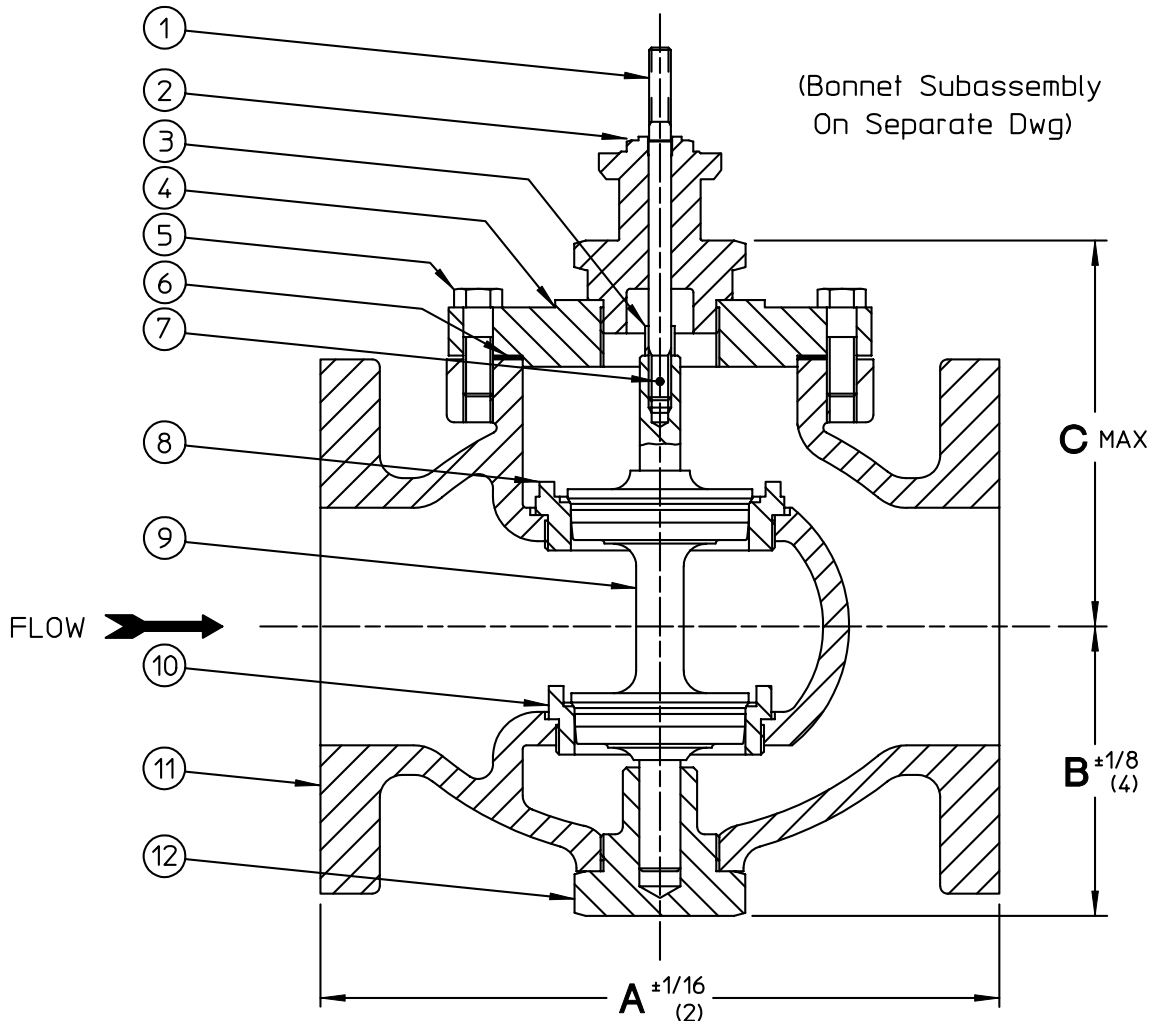

DRAWING C3760953

Teflon V-ring Packing Type 26 Stainless Steel

NOTES:

- 1) RETAINER BEARING (9) IS NOT A SYMMETRICAL PART & SHOULD ONLY BE ASSEMBLED AS FOLLOWS. PRESS RETAINER BEARING (9) INTO PACKING RETAINER (10) UNTIL THE END WITH THE CHAMFER ON THE ID IS FLUSH WITH THE TOP OF THE PACKING RETAINER (10)
- 2) PRESS BONNET BEARING (2) INTO BONNET (1), ORIENTED AS SHOWN, UNTIL IT BOTTOMS OUT IN PACKING GLAND

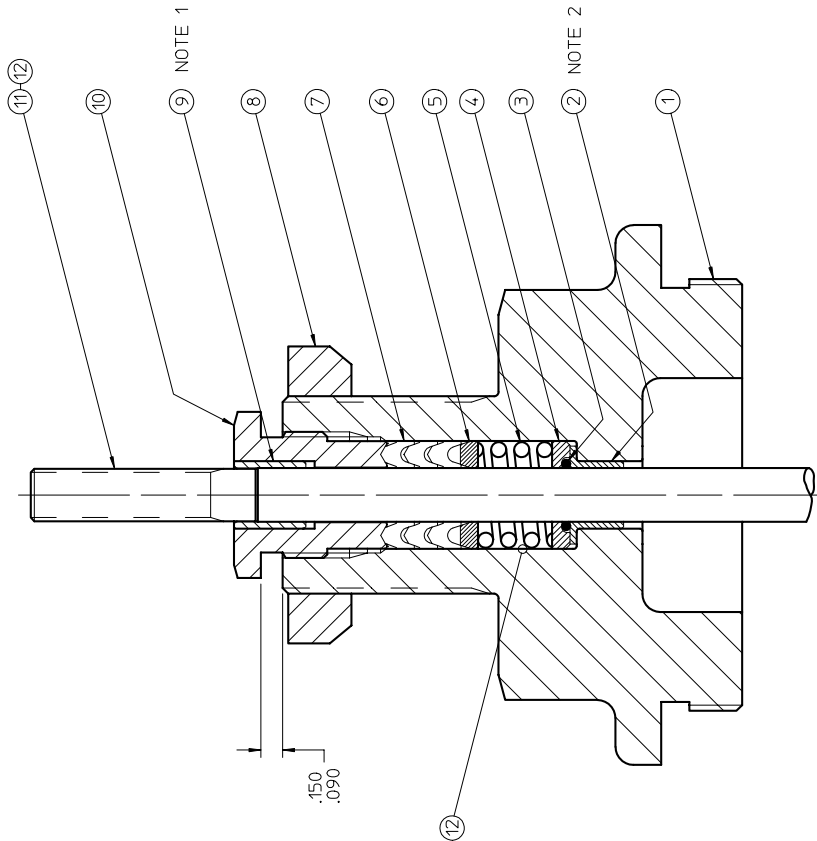

ITEM	A/R	A0940021	DCIII LUBE	DESCRIPTION	MATL SPEC
11	1	AS REQD	VALVE STEM		ST STL TYPE 316
10	1	C1720057-02	PACKING RETAINER		ST STL 300 SERIES
9	1	B1060056	RETAINER BEARING		FIBER REINFORCED POLYETHERETHERKETONE
8	1	B1640034-01	YOKE LOCKNUT		STL PLTD
7	1	A1700054	V-RING PACKING SET		TEFLON
6	1	B1010050-04	MALE ADAPTER		ST STL 300 SERIES
5	1	B1820059	SPRING		ST STL TYPE 302
4	1	B1800050-03	O-RING RETAINER		ST STL 300 SERIES
3	1	04910012	O-RING -012		TEFLON
2	1	B1060055	BONNET BEARING		FIBER REINFORCED POLYETHERETHERKETONE
1	1	SEE OTHER TABLE	BONNET		CAST ST STL ASTM A351 CF8M
ITEM	QTY	PART NO	DESCRIPTION	MATL SPEC	

-03	C1180971-01	2 INCH TYPE 2000SH
-02	C1180867-01	1 1/2 INCH TYPE 2000SH
C3760953-01	C1180668-01	1/2 - 1 INCH TYPE 2000SH
PART NO	BONNET NO	USED ON

DRAWING C3769950

Teflon V-ring Packing Type 26 Bronze & Type 22

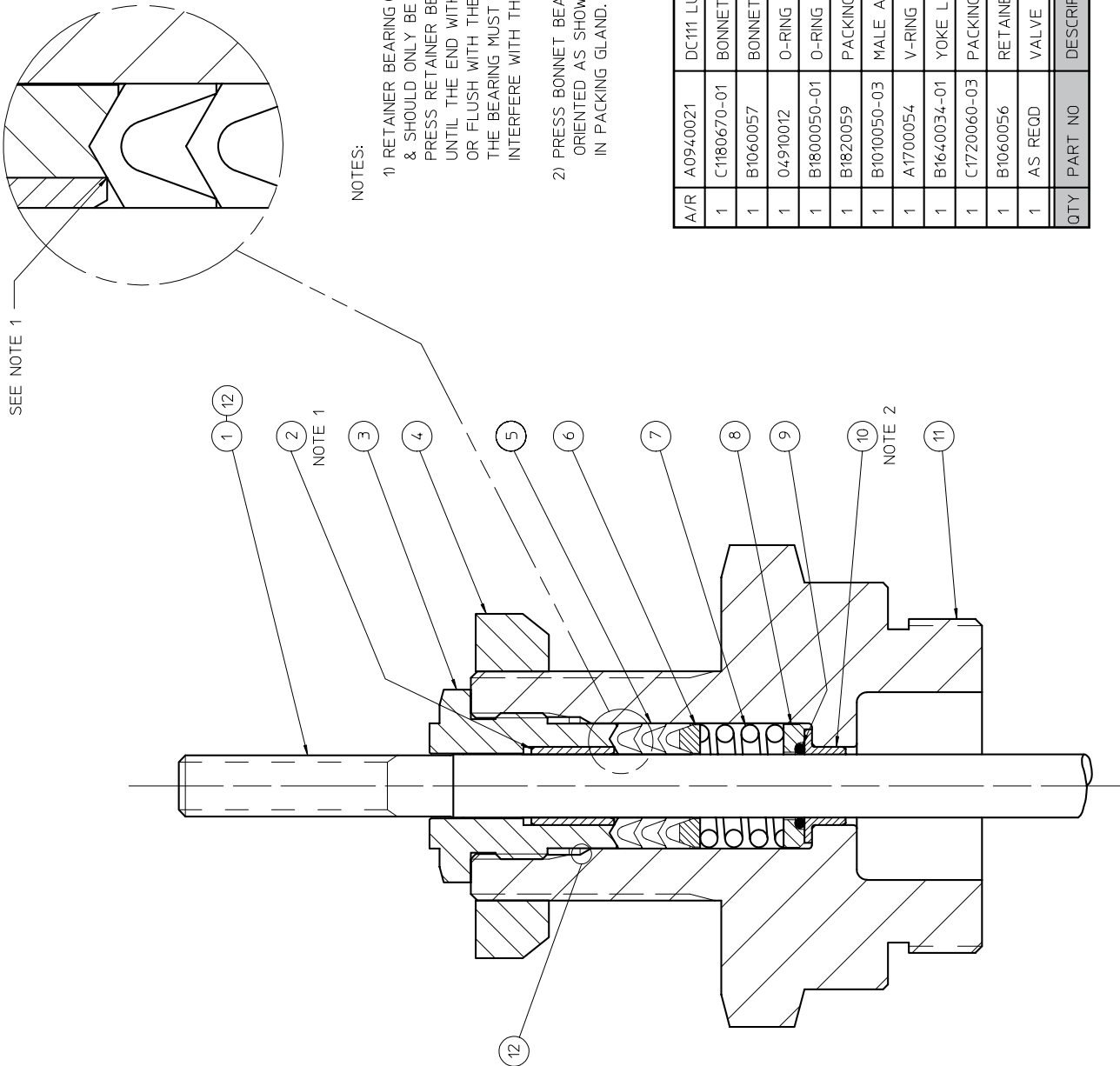

NOTES:

- 1) RETAINER BEARING (2) IS NOT A SYMMETRICAL PART & SHOULD ONLY BE ASSEMBLED AS FOLLOWS. PRESS RETAINER BEARING (2) INTO PACKING RETAINER (3) UNTIL THE END WITH THE CHAMFER ON THE ID IS ABOVE OR FLUSH WITH THE INSIDE EDGE OF THE V-NOTCH. THE BEARING MUST NOT EXTEND PAST THE V-NOTCH AND INTERFERE WITH THE V-RING PACKING.
- 2) PRESS BONNET BEARING (10) INTO BONNET (11), ORIENTED AS SHOWN, UNTIL IT BOTTOMS OUT IN PACKING GLAND.

A/R	QTY	PART NO	DESCRIPTION	MATL SPEC
A0940021	1	DC111 LUBE		
C1180670-01	1	BONNET		BRASS
B1060057	1	BONNET BEARING		FIBER REINFORCED POLYETHERETHERKETONE
04910012	1	O-RING -012		TEFLON
B1800050-01	1	O-RING RETAINER		BRASS
B1820059	1	PACKING SPRING		ST STL TYPE 302
B1010050-03	1	MALE ADAPTER		BRASS
A1700054	1	V-RING PACKING SET		TEFLON
B1640034-01	1	YOKE LOCKNUT		STEEL PLATED
C1720060-03	1	PACKING RETAINER		BRASS
B1060056	1	RETAINER BEARING		FIBER REINFORCED POLYETHERETHERKETONE
AS REQD	1	VALVE STEM		ST STL TYPE 316
QTY	PART NO	DESCRIPTION	MATL SPEC	

DRAWING C3769956

EPDM Lip Packing Type 22

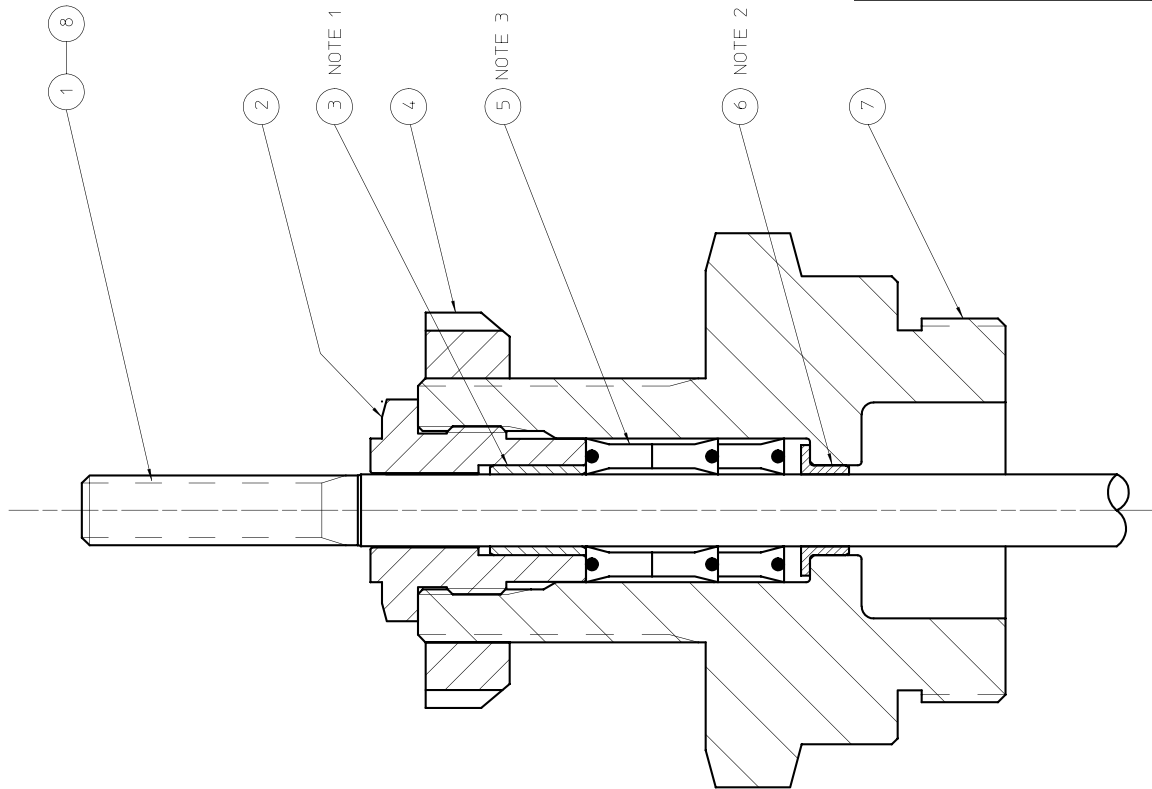

NOTES:

- 1) RETAINER BEARING (3) IS NOT A SYMMETRICAL PART & SHOULD ONLY BE ASSEMBLED AS FOLLOWS. PRESS RETAINER BEARING (3) INTO PACKING RETAINER (2) UNTIL THE END WITH THE CHAMFER ON THE ID IS ABOVE OR FLUSH WITH THE BOTTOM OF THE PACKING RETAINER (2).
- 2) PRESS BONNET BEARING (6) INTO BONNET (7), ORIENTED AS SHOWN, UNTIL IT BOTTOMS OUT IN PACKING GLAND.
- 3) PROTECT ID & OD SEALING LIPS OF PACKING FROM CUTS, NICKS OR SCRAPES DURING INSTALLATION. DO NOT FORCE SEALING LIPS PAST BONNET THREADS OR STEM THREADS. USE OF INSTALLATION SLEEVE IS RECOMMENDED. LUBRICATE PACKING ID & OD AND STEM BEFORE INSTALLATION. PACKING MUST BE ORIENTED AS SHOWN.

8	A/R	A0940021	DC11 LUBE		
7	1	C1180670-01	BONNET		BRASS ASTM B16 H02
6	1	B1060057	BONNET BEARING		FIBER REINFORCED POLYETHERETHERKETONE
5	3	4207-18700375-312	LIP PACKING		HIGH TEMP ETHYLENE PROPYLENE 90 DURO
4	1	B1640034-01	YOKE LOCKNUT		STL PLTD
3	1	B1060056	RETAINER BEARING		FIBER REINFORCED POLYETHERETHERKETONE
2	1	C1720061-03	PACKING RETAINER		BRASS ASTM B16
1	1	AS REQD	VALVE STEM		ST STL TYPE 316
ITEM QTY PART NO			DESCRIPTION	MATL SPEC	

DRAWING 03000521101

Lever Actuator

ITEM	PART NOMENCLATURE
1	LEVER BRACKET
2	LEVER ARM
3	CLEVIS
4	HEX JAMNUT
5	CLEVIS PIN
6	COTTER PIN
7	PIVOT ARM
8	CLEVIS PIN
9	WEIGHT
10	HEX CAPSCREW

NOTES:

- 1) LOCATION OF WEIGHT (9) ON LEVER ARM (2) TO BE DETERMINED BY CUSTOMER
- 2) DIMENSIONS IN PARENTHESES ARE IN MILLIMETERS

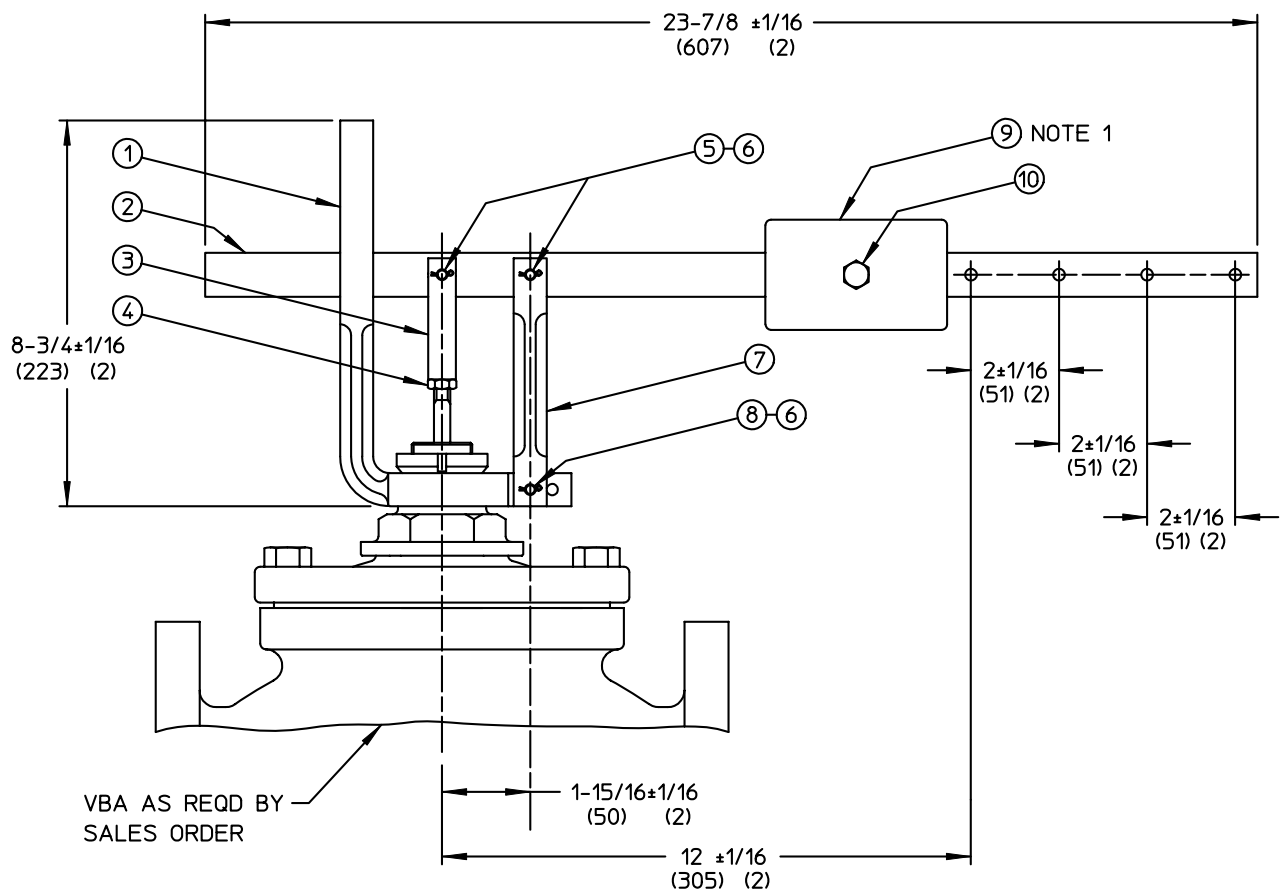

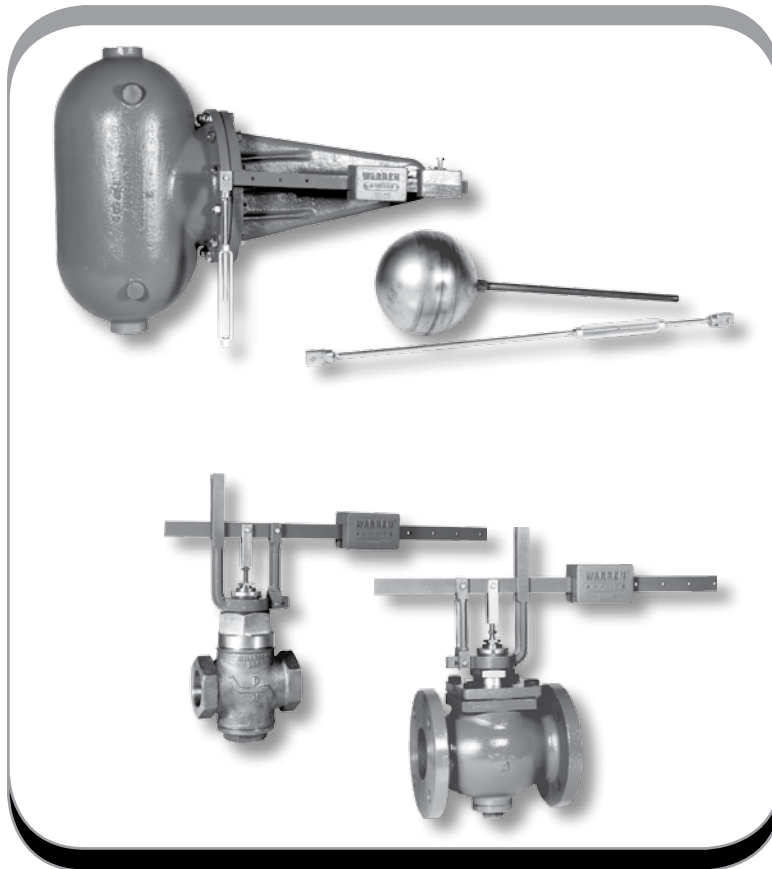

WARREN CONTROLS