



KUNKLE MODELS 215V/337 VACUUM RELIEF AND SAFETY VALVES
SAFETY AND RELIEF PRODUCTS

Cast iron non-code vacuum relief and ASME Section VIII and Section XIII air/gas, 'UV', National Board certified safety valves, both PED certified for non-hazardous gas



MODEL 215V



MODEL 337

FEATURES

- Large nozzle design provides high capacity.
- Flat bronze valve seats are lapped for optimum performance.
- Warn ring offers easy adjustability for precise opening with minimum pre-open or simmer.
- Pivot between disc and spring corrects misalignment and compensates for spring side thrust.
- Model 215V has seal cap for vacuum service.
- Model 337 has 'lift-pin' lift device for easy manual testing.
- Bronze nozzle and disc as standard. Optional SS trim available.
- Each valve tested and inspected for pressure setting and leakage.

NOTES

1. ASME valves made from cast iron; A126 may not be used for lethal or flammable service.
2. Model 215V valves are not suitable for positive pressure.

GENERAL APPLICATION

Model 215V is suitable for the protection of high volume vacuum pumps, conveying systems and light gauge tanks. Model 337 for the protection of low to medium pressure high volume blowers, compressors, conveying systems and bulk hauling trailers/equipment.

TECHNICAL DATA

Connections:	Threaded NPT or BSPT
Temperature range:	-20° to 406°F (-29° to 208°C)
Vacuum range (Type 215V):	2" to 29" Hg (67.7 to 982 mbarg)
Pressure range (Type 337):	1 to 60 psig (0.07 to 4.1 barg)
Codes Type 215V:	PED CE
Type 337:	ASME VIII, XIII (UV Designator) and PED



KUNKLE MODELS 215V/337 VACUUM RELIEF AND SAFETY VALVES

SAFETY AND RELIEF PRODUCTS

PARTS AND MATERIALS

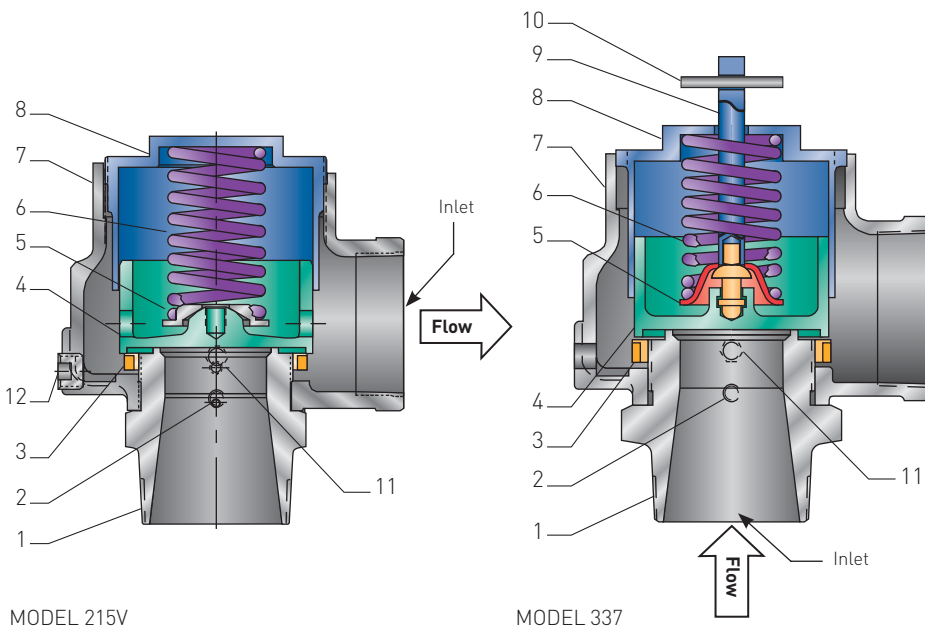

MODEL 215V

MODEL 337

MODELS 215V AND 337

No.	Part name	215V	337
1	Nozzle ^[1]	Bronze, SB62 or brass B283-C48500	Bronze, SB62 or brass B283-C48500
2	Set screw	Steel A108-1018 brass plated	Steel A108-1018 brass plated
3	Regulator ring	Bronze B584 alloy 84400	Bronze B584-C84400
4	Disc ^[1]	Bronze B584 alloy 84400	Bronze B584-C84400
5	Spring step	Steel A-109 coated ^[3]	Steel A109 coated ^[3]
6	Spring	SS, A313 TY 302 or 17-7	SS, A313 TY 302 or 17-7
7	Body	Cast iron A-126, CL A or B	Iron A-126, CL A or B
8	Compression screw	Bronze, B-584 alloy 84400	Bronze, B584-C84400
9	Stem ^[2]	N/A	Brass B16
10	Lift pin ^[2]	N/A	Steel, zinc plated
11	Regulator ring set screw	N/A	Brass B16
12	NPT drainplug	Steel A108-1018	N/A

NOTES

1. Disc and nozzle available in SSA-479 TY 316.
2. Stem and lift pin available on Model 337 only.
3. Corrosion preventative coating.

SPECIFICATIONS

Size inlet and outlet NPS (DN)	Dimensions, in inch (mm)				Weight lb (kg)
	A	B	C 215V	C 337	
2 (50.8)	3 ¼ (82.5)	3 (76.2)	6 ½ (165.1)	7 (177.8)	8 (3.6)
2½ (63.5)	3 ¾ (95.2)	3 ½ (88.9)	7 ⅝ (194.6)	8 (203.2)	12 (5.4)
3 (76.2)	4 ¼ (107.9)	4 (101.6)	8 ½ (215.9)	9 (228.6)	20 (9.07)

Dimensions are for reference only.

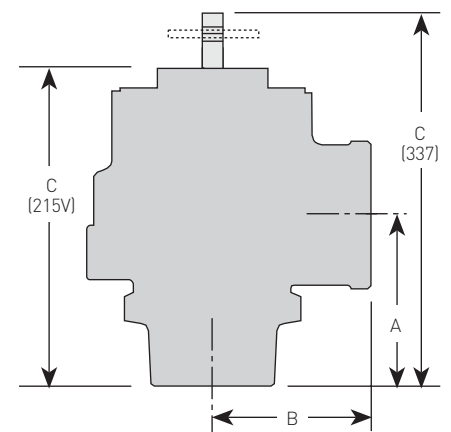

MODEL 337

KUNKLE MODELS 215V/337 VACUUM RELIEF AND SAFETY VALVES

SAFETY AND RELIEF PRODUCTS

CAPACITIES

MODEL 337, non-code⁽¹⁾ and ASME section VIII and section XIII air (SCFM), flow coefficient = 0.860

Set pressure (psig)	Valve inlet and outlet size		
	2"	2½"	3"
	Orifice area, in ²		
	1.916	2.786	4.037
1	250	364	527
5	553	805	1166
10	773	1124	1628
15	988	1436	2081
20	1139	1656	2399
25	1290	1875	2718
30	1441	2095	3036
35	1607	2337	3386
40	1773	2578	3736
45	1939	2820	4086
50	2105	3061	4436
55	2271	3303	4786
60	2438	3544	5136

NOTE

1. No code stamp or 'NB' on nameplate below 15 psig set.

MODEL 337, non-code⁽¹⁾ and ASME section VIII and section XII air (Nm³/h), flow coefficient = 0.860 - metric units

Set pressure (barg)	Valve inlet and outlet size		
	50 mm	63 mm	80 mm
	Orifice area		
	(12.361 cm ²)	(17.974 cm ²)	(26.045 cm ²)
0.5	1056	1536	2226
1.0	1468	2135	3094
1.5	1901	2765	4006
2.0	2251	3273	4743
2.5	2631	3825	5543
3.0	3015	4385	6553
3.5	3400	4944	7164
4.0	3784	5503	7974

NOTE

1. No code stamp or 'NB' on nameplate below 1.1 barg set.

MODEL 215V, non-code vacuum air (SCFM), flow coefficient = 0.860

Relief set (in, HG)	Valve inlet and outlet size		
	2"	2 ½"	3"
	Orifice area, in ²		
	1.916	2.786	4.037
2	239	347	503
5	352	512	742
10	433	630	912
15	444	646	936
20	444	646	936
29	444	646	936

NOTE

1. Based on 10% accumulation.

MODEL 215V, non-code vacuum air (Nm³/h), flow coefficient = 0.860 - metric units

Relief set (mbarg)	Valve inlet and outlet size		
	50 mm	63 mm	80 mm
	Orifice area		
	(12.361 cm ²)	(17.974 cm ²)	(26.045 cm ²)
50	330	481	696
100	453	658	954
150	536	779	1129
200	597	868	1257
250	641	933	1351
300	673	979	1419
350	694	1010	1463
400	705	1026	1486
450	708	1030	1492
500	713	1037	1503
550	713	1037	1503
600	713	1037	1503
650	713	1037	1503
700	713	1037	1503
750	713	1037	1503

NOTE

1. Based on 10% accumulation.

KUNKLE MODELS 215V/337 VACUUM RELIEF AND SAFETY VALVES

SAFETY AND RELIEF PRODUCTS

SELECTION GUIDE

Example:	215V	-	H	01	A	Q	E	0015
Model								
215V								
0337								
Inlet size								
H			2" (50.8 mm)					
J			2½" (63.5 mm)					
K			3" (76.2 mm)					
Variation								
01				Bronze disc and nozzle				
03				SS disc and nozzle				
60				BSPT connections				
63				SS disc and nozzle with BSPT connections				
Design revision								
Indicates non-interchangeable revision								
Current design is at revision 'A'								
Valve service								
K				Air ASME section VIII and section XIII (model 337 only)				
Q				Vacuum (model 215V only)				
N				Non-code air/gas (model 337 only)				
Spring material								
215V:								
E				SST type 302 or type 17-7				
337:								
E				SST type 302 (H-orifice up to 8 psi; J-orifice up to 20 psi; K-orifice up to 25 psi)				
M				SST type 17-7 (H-orifice above 8 psi; J-orifice above 20 psi; K-orifice above 25 psi)				
Set pressure								
337				1 psig (0.7 barg) (0001) to 60 psig (4.1 barg) (0060)				
215V				2" Hg (68 mbarg) (0002) to 29" Hg (982 mbarg) (0029) vacuum				

VCTDS-00383 © 2016, 2022 Emerson Electric Co. All rights reserved 04/22. Kunkle™ is a mark owned by one of the companies in the Emerson Automation Solutions business unit of Emerson Electric Co. The Emerson logo is a trademark and service mark of Emerson Electric Co. All other marks are the property of their prospective owners.

The contents of this publication are presented for informational purposes only, and while every effort has been made to ensure their accuracy, they are not to be construed as warranties or guarantees, express or implied, regarding the products or services described herein or their use or applicability. All sales are governed by our terms and conditions, which are available upon request. We reserve the right to modify or improve the designs or specifications of such products at any time without notice.

Emerson Electric Co. does not assume responsibility for the selection, use or maintenance of any product. Responsibility for proper selection, use and maintenance of any Emerson Electric Co. product remains solely with the purchaser

Emerson.com