

EXHAUST HEADS

Carbon or Stainless Steel Construction • Threaded or Flanged Connections

Helps Reduce
Roof Maintenance
Costs



Type 40EHC
(cast)



Type 40EHMF
(fabricated)

FEATURES

- Choice of Cast or Fabricated Construction
- Removes 99% of Liquid and Solid Entrainment Particles Larger Than 10 Microns
- No Required Maintenance
- Highly Efficient
- Virtually No Back Pressure

Wright-Austin Exhaust Heads are designed to separate entrained water and oil from exhaust air, gas or steam prior to being discharged directly into the atmosphere. They will remove more than 99% of liquids and solids over 10 microns in size from the discharged flow, reducing maintenance costs on roofs and surrounding objects.

Operation

The moisture laden gas, air or steam enters at the inlet of the exhaust head where it is directed into a centrifugal upward motion. The entrained solids and moisture droplets are separated out by a reduction in velocity. Separated material falls into a drain reservoir.

Type 40EHC Exhaust Head

Rugged Cast Construction

The Wright-Austin Type 40EHC exhaust head is designed for long service life...with body, cover and separating element made of high tensile strength cast iron. Sizes 4" and smaller have threaded (NPT) connections. Sizes 3" and 4" and larger have 125# Flanged connections. The flange bolt holes are drilled

to straddle the center line of the drain outlet. Flanges are cast integral with the body and have slotted holes which are recessed to prevent the bolt heads from turning (except for the 3" and 4" sizes which is available with flanged or threaded connections).

Type 40EHMF Exhaust Head

Fabricated Carbon or Stainless Steel Construction

The Wright-Austin Type 40EHMF exhaust head muffler is fabricated from carbon or stainless steel and is electrically welded at all joints to withstand heavy duty usage. These exhaust heads work at high temperatures and remain efficient even when steam or gas is discharged at high velocities. The Type 40EHMF has been designed to minimize the noise associated with high discharge velocities.

The units permit free flow of steam, gas or vapors with an absolute minimum of back pressure. They feature a separating element of 304L stainless steel and the entire exhaust head can be ordered in 304L or 316L stainless steel if required.

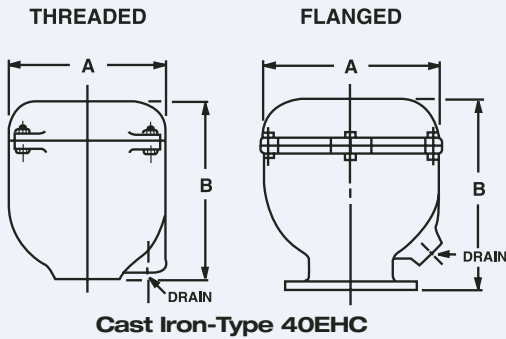

Cast Iron-Type 40EHC

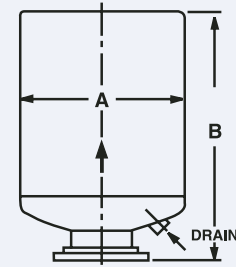

Fabricated Carbon or Stainless Steel- Type 40EHMF

Dimensions - Type 40EHC (in/mm)

	Pipe Size	Diameter A	Height B	Drain Connection (NPT)	Flange O.D.	Weight (lb)	Capacity (lb) Exhaust Stream/Hr at Atmospheric Pressure (14.7 psia)	Capacity (SCFM) Exhaust Air at Atmospheric Pressure (14.7 psia)
Threaded Inlet	1	5.25 / 133	6.12 / 156	1/2	—	11 / 5	160	45
	1-1/2	5.25 / 133	6.12 / 156	1/2	—	11 / 5	370	100
	2, 2-1/2	7.5 / 190	8.87 / 225	3/4	—	25 / 12	1,000	280
	3	8.75 / 222	11.25 / 286	3/4	—	40 / 18	2,100	500
	4	10 / 254	11.87 / 392	1	—	50 / 23	2,700	700
Flanged Inlet	4	10 / 254	15 / 381	1	9 / 229	68 / 31	2,700	700
	5	13 / 330	14 / 356	1-1/2	10 / 254	90 / 41	4,000	1,100
	6	14.75 / 375	18.75 / 476	1-1/2	11 / 279	115 / 52	6,000	1,700
	8	18 / 457	20 / 508	2	13.5 / 343	190 / 86	10,500	2,900
	10	23 / 584	24 / 610	2	16 / 406	335 / 152	16,000	4,500

Dimensions - Type 40EHMF (in/mm)

Pipe Size	Diameter of Outlet	A	B	Drain Size	Drain Type	Weight (lb/kg)	Capacity (lb) Exhaust Stream/Hr at Atmospheric Pressure (14.7 psia)	Capacity (SCFM) Exhaust Air at Atmospheric Pressure (14.7 psia)
2-1/2	2.5 / 63	8.62 / 219	16 / 406	1	NPT	55 / 25	1,000	280
3	3 / 76	10.75 / 273	19 / 483	1-1/2	NPT	65 / 30	1,600	410
4	4 / 102	14 / 356	24 / 610	1-1/2	NPT	100 / 45	2,700	700
5	5 / 127	16 / 406	26 / 660	1-1/2	NPT	130 / 59	4,000	1,100
6	6 / 152	18 / 457	30 / 762	1-1/2	NPT	140 / 64	6,000	1,700
8	8 / 203	20 / 508	36 / 914	2	NPT	240 / 109	10,500	2,900
10	10 / 254	24 / 610	42 / 1,067	2	NPT	390 / 177	16,000	4,500
12	12 / 305	30 / 762	48 / 1,219	2-1/2	NPT	550 / 250	24,000	6,500
14	14 / 356	36 / 914	54 / 1,372	2-1/2	NPT	700 / 341	34,000	8,800
16	16 / 406	40 / 1,016	60 / 1,524	3	NPT	850 / 386	44,000	11,500
18	18 / 457	42 / 1,067	66 / 1,676	3	NPT	1,175 / 534	52,000	14,500
20	20 / 508	48 / 1,219	72 / 1,829	3	NPT	1,500 / 682	66,000	17,000
24	24 / 610	54 / 1,372	84 / 2,134	4	Flanged	1,850 / 841	94,000	26,000
30	30 / 762	72 / 1,829	102 / 2,591	4	Flanged	2,100 / 955	145,000	40,000
36	36 / 914	78 / 1,981	112 / 2,845	4	Flanged	4,500 / 2,045	210,000	55,000
42	42 / 1,067	96 / 2,438	130 / 3,302	4	Flanged	6,100 / 2,773	290,000	76,000
48	48 / 1,219	102 / 2,591	148 / 3,760	4	Flanged	7,800 / 3,545	375,000	99,000