

TYPE D50 PRESSURE REDUCING VALVE

PRESSURES to 300 PSIG at 420°F



**TYPE D50 DIRECT ACTING
PRESSURE REDUCING VALVE**

- Direct Acting
- Steam, Water or Gas
- Spherical Seating Surface on Floating Stainless Steel Disc for Tight Shutoff
- Unique Adjustable Aspirator
- Five Spring Ranges
- Integral Stainless Steel Strainer
- ANSI/FCI 70-2 Class IV Shutoff

OPTIONS

- Teflon® Disc for Dead-end Service for Liquid and Gas

Installation Tip: Add Uniflex Pipe Coupling for ease of maintenance

APPLICATION DATA

- Steam Irons
- Autoclaves
- Laundry Mangles
- Single Radiators
- Steam Tables
- Vulcanizers

VALVE RATINGS

Body Material	Pressure PSIG (bar)	Temperature °F (°C)
WITH ST. STL. DISC		
Cast Iron	200 (13.8)	@ 400 (204.4)
Stainless Steel	300 (21.0)	@ 420 (215.6)
WITH TEFLON® DISC		
All	300 (21.0)	@ 300 (148.9)
	200 (13.8)	@ 400 (204.4)

SPRING RANGES

3-15	All Sizes	75-140	1/2-1 1/4" CI & Brz.
10-50	All Sizes	30-100	1 1/2-2" CI
25-80	1/2-1 1/4" C.I. & Brz.	30-140	1/2-1" St. Stl.

Canadian Registration # OC 0591.9C

SIZING INFO

RATED FLOW COEFFICIENTS (Cv)

VALVE SIZE					
1/2	3/4	1	1 1/4	1 1/2	2
2.2	3.3	4.9	5.0	10.1	10.8

TYPE D50 PRESSURE REDUCING VALVE

SPECIFICATION

The valve shall be self operated, requiring no external energy source. The valve shall operate quickly and provide dead end shut-off. The body materials and rating shall be cast iron for 200 psig and 400°F, Bronze or Stainless Steel for 300 psi and 420°F. Valve trim material is to be stainless steel. Valve to have a standard aspirator to allow for adjustment of operation.

MATERIALS OF CONSTRUCTION

Body, Cast IronASTM 126 Cl. B
 Body, BronzeASTM B61-80 UNS C92200
 Body, St. Stl.....ASTM 743 CF-8M
 Stem304 St. Stl ASTM 276 Cond. A
 Disc.....316 St. Stl. ASTM 276 Cond. A
 Seat304 St. Stl ASTM 276 Cond. A
 Gasket.....Teflon
 Diaphragm304 St. Stl ASTM 276 Cond. A
 Spring302 St. Stl.

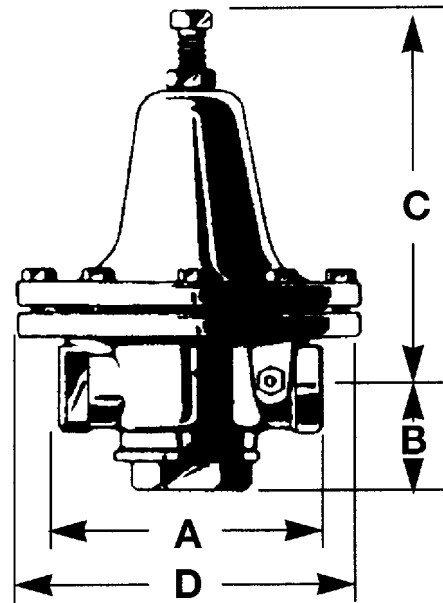

TYPE D50 DIRECT ACTING PRESSURE REDUCING VALVE

DIMENSIONS inches (mm) AND WEIGHTS pounds (kg)

Body Mat'l.	Size	Dimensions, Inches				Weight (lbs.)
		A	B	C	D	
C.I. & Brz	1/2, 3/4 (13, 19)	4 5/8 (143)	1 3/4 (44)	6 7/8 (175)	6 (152)	12 (5.5)
C.I.	1, 1 1/4 (25, 32)	5 5/8 (143)	2 (51)	7 1/4 (184)	7 1/2 (191)	19 (8.6)
C.I.	1 1/2, 2 (38, 51)	6 5/8 (168)	2 3/4 (70)	11 1/2 (292)	9 (229)	30 (13.6)
St. Stl.	1/2 (13)	5 (127)	1 5/8 (41)	5 1/2 (140)	4 7/8 (124)	8 (3.6)
St. Stl.	3/4, 1 (19, 25)	5 5/8 (143)	2 1/4 (57)	6 1/2 (165)	7 7/16 (191)	22 (10)