



TITAN FLOW CONTROL, INC.

FOOT VALVE ASSEMBLY ♦ GLOBE STYLE DESIGN

ASME CLASS 150 ♦ DUCTILE IRON ♦ FLANGED ENDS

MODEL: FV 50-DI
(DUCTILE IRON)

SIZE RANGE: 2" ~ 12"

LARGER SIZES AVAILABLE: UP TO 24"

DESIGNED TO SILENTLY
MAINTAIN PRIME DURING
PUMP OUTAGE



FEATURES

♦ DESIGNED FOR LONG SERVICE LIFE

DUCTILE IRON BODY MAINTAINS THE ANTI-CORROSIVE PROPERTIES OF CAST IRON WHILE ACHIEVING A YIELD STRENGTH COMPARABLE TO CARBON STEEL. DUCTILE IRON ALSO OFFERS HIGHER PRESSURE/TEMPERATURE RATINGS THAN CAST IRON. CARBON AND STAINLESS STEEL UNITS ARE ALSO AVAILABLE UPON REQUEST.

♦ MINIMAL HEAD LOSS

HEAD LOSS IS MINIMIZED BY PROVIDING A LARGE CROSS-SECTIONAL AREA WHICH EXCEEDS THAT OF THE ADJACENT PIPELINE. ADDITIONALLY, THE SPRING-LOADED, CENTER GUIDED DISC IS DESIGNED WITH VERY LOW CRACKING PRESSURE WHICH REDUCES THE AMOUNT OF ENERGY REQUIRED TO OPEN THE VALVE.

♦ QUICK CLOSURE TO REDUCE WATER HAMMER

SILENT SHUT-OFF IS ACHIEVED VIA THE FULLY AUTOMATIC, SPRING ASSISTED DISC THAT CLOSES NEAR ZERO FLOW VELOCITY. THE LIGHTWEIGHT, CENTER GUIDED DISC DESIGN CREATES A POSITIVE SHUTOFF PRIOR TO FLOW REVERSAL AND HELPS TO KEEP SLAMMING AND SURGES TO A MINIMUM.

♦ BRONZE METAL-TO-METAL SEATS

PRECISION MACHINED SEALING SURFACES ALLOW THE FV 50-DI TO MAINTAIN A TIGHT SEAL THAT MEETS OR EXCEEDS API 598 LEAKAGE REQUIREMENTS. RESILIENT SEATS ARE ALSO AVAILABLE TO PROVIDE BUBBLE TIGHT SEALS.

♦ NUMEROUS SCREEN OPTIONS

THE STANDARD SCREEN CONSTRUCTION MATERIAL IS TYPE-304 STAINLESS STEEL. IN ADDITION, A WIDE VARIETY PERFORATIONS, MESHES, AND MATERIALS ARE READILY AVAILABLE. SCREENS CAN BE BASKET SHAPED OR CONE SHAPED.

TECHNICAL

PRESSURE/TEMPERATURE RATING ⁽¹⁾
DUCTILE IRON - ASTM A536 - CLASS 150

WOG (Non-shock): 250 PSI @ 100 °F

TEMPERATURE RANGE

-20 ~ 450 °F

SPRING MATERIAL
MAXIMUM TEMPERATURE

Stainless Steel: 450 °F

1. The bolting pattern for Cast Iron ASME Class 125 and Ductile Iron ASME Class 150 are identical thus they are interchangeable.
2. The above listed temperatures are theoretical and may vary during actual operating conditions.
3. Longterm use at maximum temperature is not recommended for optimal performance. Longterm use at maximum temperature will result in performance degradation.

APPLICATIONS

GENERAL APPLICATION: A FOOT VALVE IS A SPECIAL TYPE OF CHECK VALVE THAT HAS A BUILT-IN STRAINER. IT IS INSTALLED AT THE INTAKE SIDE OF A SUCTION PIPE AND PUMP. ITS PURPOSE IS TO PREVENT THE LOSS OF PRIME WHEN THE LIQUID SOURCE (WET WELL) IS LOWER THAN THE PUMP. PRIME IS DEFINED AS THE CHARGE OF LIQUID REQUIRED TO BEGIN PUMPING ACTION AND PRIMING IS THE PROCESS OF FILLING THE PUMP AND SUCTION PIPE WITH LIQUID.

THE CHECK VALVE PART OF THE FOOT VALVE OPENS WHEN THE PUMP STARTS TO ALLOW LIQUID TO ENTER THE SUCTION PIPE AND PUMP. WHEN THE PUMP STOPS THE CHECK VALVES CLOSES AND PREVENTS THE LIQUID FROM EMPTYING. THUS THE FOOT VALVE ELIMINATES THE NEED TO PRIME THE PUMP EACH TIME IT IS STARTED. THE STRAINER COMPONENT OF THE FOOT VALVE HELPS TO REMOVE UNWANTED DEBRIS FROM THE LIQUID THAT MAY CAUSE DAMAGE TO THE PUMP.

The above data represents common market and service applications. No representation or guarantee, expressed or implied, is given due to the numerous variations of concentrations, temperatures and flow conditions that may occur during actual service.

TITAN® FLOW CONTROL, INC.
YOUR PIPELINE TO THE FUTURE!

Tel: 910-735-0000 ♦ Fax: 910-738-3848 ♦ titan@titanfci.com ♦ www.titanfci.com
290 Corporate Drive ♦ PO Box 7408 ♦ Lumberton, NC 28358



TITAN® FLOW CONTROL, Inc.

290 Corporate Drive
Lumberton, NC 28358
Tel: 910.735.0000

E-mail: titan@titanfci.com
Web: www.titanfci.com
Fax: 910.738.3848

FOOT VALVE ASSEMBLY

FV 50-DI (Ductile Iron)

Flanged Ends • Globe Style • Center Guided Disc

ASME Class
150 lb

BILL OF MATERIALS (1)

No.	PART	FV 50-DI
1	Body	Ductile Iron ASTM A536
2	Disc (2)	Cast Bronze ASTM B62
3	Spring (2)	Series 300 Stainless Steel
4	Bushing (2)	Cast Bronze ASTM B62
5	Seat (2) (3)	Cast Bronze ASTM B62
6	Bolts	Stainless Steel
7	Screen	Type 304 Stainless Steel

1. Bill of Materials represents standard materials. Equivalent or better materials may be substituted at the manufacturer's discretion.
2. Denotes recommended spare parts.
3. Resilient Seats (Buna-N) are available upon request.

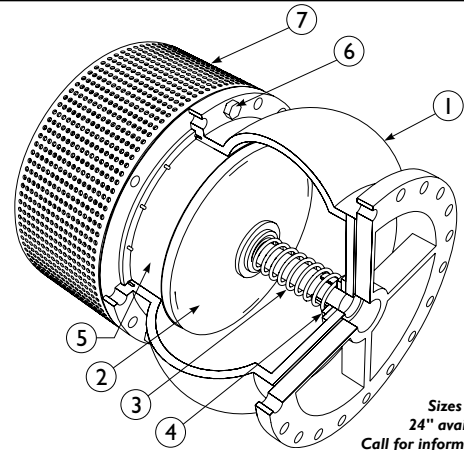
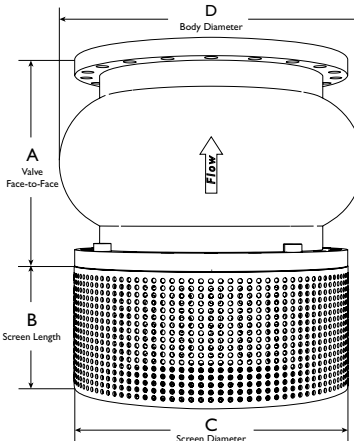

Sizes up to 24" available.
Call for information.

DIMENSIONS AND PERFORMANCE DATA (1)

SIZE	in	2	2 1/2	3	4	5	6	8	10	12
	mm	50	65	80	100	125	150	200	250	300
A DIMENSION FACE TO FACE	in	6.25	7.00	7.50	8.50	9.50	10.50	13.50	16.25	20.25
	mm	159	178	191	216	242	267	343	413	515
B DIMENSION SCREEN LENGTH	in	3.00	3.00	3.00	3.00	4.00	5.00	6.00	7.00	8.00
	mm	77	77	77	77	102	127	153	178	204
ØC DIMENSION SCREEN DIAMETER	in	6.00	7.00	7.50	9.00	10.00	11.00	13.50	16.00	19.00
	mm	153	178	191	229	254	280	343	407	483
ØD DIMENSION BODY DIAMETER	in	4.625	5.75	6.625	8.625	10.00	11.125	15.84	17.687	21.25
	mm	117	146	168	219	254	283	402	449	540
ASSEMBLED WEIGHT	lb	25.0	35.0	36.5	61.0	76.0	91.5	180.0	265.0	411.0
	kg	11.3	15.9	16.6	27.7	34.5	41.5	81.6	120.1	186.2
Flow Coefficient	C _v	65	105	150	265	410	600	1100	1800	2500
Cracking Pressure (2)	psi	≤ .5	≤ .5	≤ .5	≤ .5	≤ .5	≤ .5	≤ .5	≤ .5	≤ .5

1. Dimensions, weights, and flow coefficients are provided for reference only. When required, always request certified drawings.
2. Cracking pressure is for horizontal installations only. For vertical installations, please consult factory.

Additional Design & Technical Notes:

- The FV 50-DI is designed to fit Cast Iron ASME Class 125 and Ductile Iron ASME Class 150 Flanges. The bolting pattern for Cast Iron ASME Class 125 and Ductile Iron ASME Class 150 are identical.
- Ductile Iron body maintains the anti-corrosive properties of Cast Iron while achieving a yield strength comparable to Carbon Steel. Ductile Iron also offers higher pressure & temperature ratings than Cast Iron.
- Screens are available in either basket shaped or cone shaped. A wide variety of perforations, meshes, and materials are available for screens.
- Resilient seats (Buna-N) are available upon request. Please contact factory.

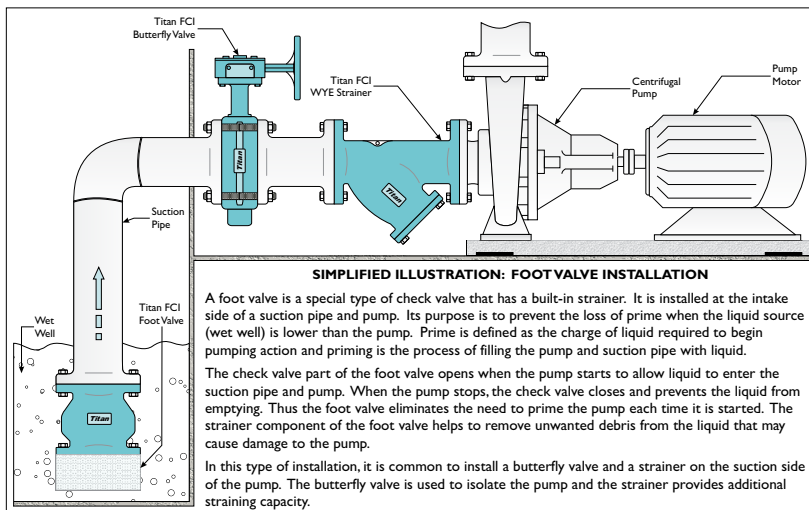

PRESSURE - TEMPERATURE RATINGS (1)

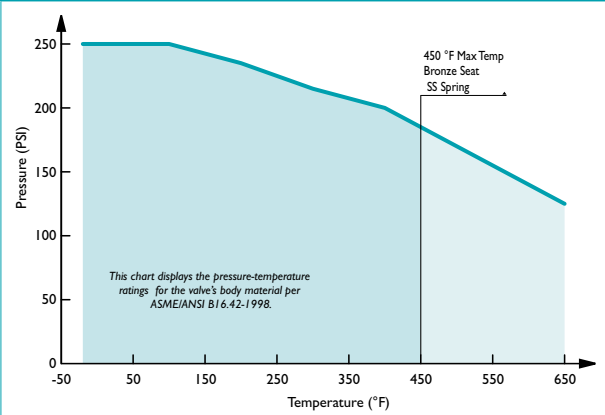

1. This chart displays the pressure-temperature ratings for the valve's body. Max temperature limits have been added for seat and spring materials.

PRESSURE - TEMPERATURE RATING

ASME CLASS 150	ASTM A536
WOG (Non-shock)	250 PSI @ 100 °F

1. The listed pressure and temperature ratings are theoretical and may vary during actual operating conditions.
2. Longterm use at maximum temperature is not recommended for optimal performance. Longterm use at maximum temperature will result in performance degradation.

As †Titan product changes occur, there may be short-term differences between actual product specifications and the information contained within our literature. †Titan FCI reserves the right to make design and specification changes to improve our products without prior notification. When required, request certified drawings. †TITAN is a registered trademark of Titan Flow Control Incorporated.

MAX TEMPERATURE SPRING

SPRING	Max Temperature
Stainless Steel	450 °F

TEMPERATURE RANGE SEAT

SEAT	Temperature
Bronze	-20 °F @ 450 °F

REFERENCED STANDARDS & CODES

CODE	DESCRIPTION
ASME B16.42	Ductile Iron Pipe Flanges and Flanged Fittings
ASME B16.5	Pipe Flanges & Flanged Fittings
MSS SP-6	Standard Finishes for Connecting-end Flanges
MSS SP-25	Standard Marking System for Valves
MSS SP-55	Quality Standard for Valve Castings