

HEAT-TIMER[®]

Installation and Operation Manual

Motorized Stainless 2-Way Valves

Safety Valve—ETV Applications

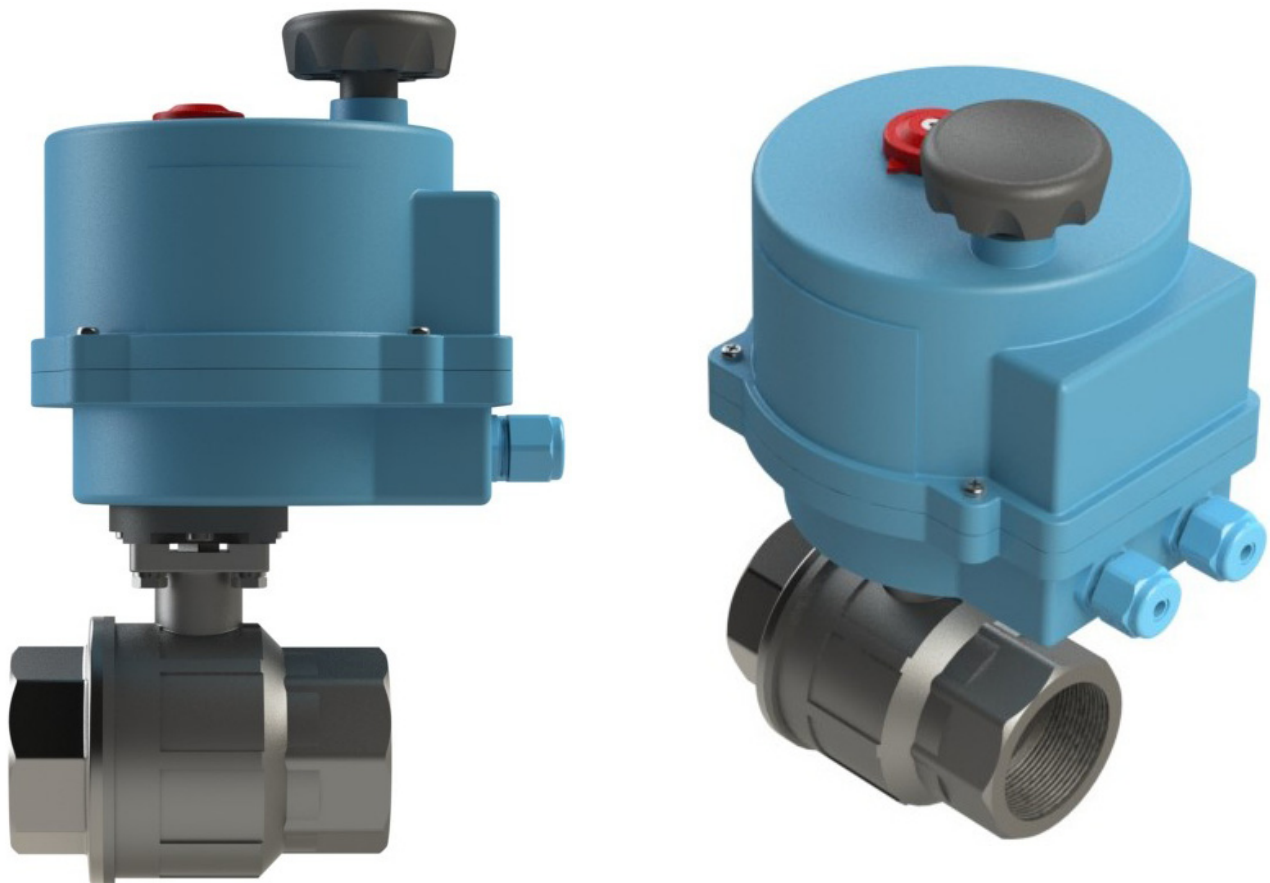

⚠ WARNING

This Heat-Timer valve is strictly an operating valve; it should never be used as a primary limit or safety control. All equipment must have its own certified limit and safety controls required by local codes. The installer must verify proper operation and correct any safety problems prior to the installation of any Heat-Timer equipment.

Table of Contents

Controls, Indicators, and Connections	3
Detailed Operation	5
Overview	5
Actuator Status LEDs	5
Battery Backup	5
Actuator Manual Operation	6
Maintenance	7
Specifications	8
Actuator Specifications	8
2-Way Valve Specifications	10
Installation Instructions	11
Supplied Materials	11
Required Materials (Not Supplied)	11
Design Considerations	11
Installing the Valve Body	12
Wiring the Actuator	13
Mounting the Actuator Power Transformer	13
Removing the Actuator Cover	14
Power Input Wiring	14
Connecting the Actuator to an ETV Platinum Plus Control	15
Completing the Wiring	16
Valves 1 1/2" or larger and Valves with Battery Backup	
Removing the Actuator Cover	17
Power Input Wiring	17
Connecting the Actuator to an ETV Platinum Plus Control	18
Completing the Wiring	19
Troubleshooting	20
Notes	21
Warranty	24

Controls, Indicators, and Connections

Figure 1A: Motorized Stainless 2-Way Valves (1 1/4" and smaller) Controls, Indicators, and Connections

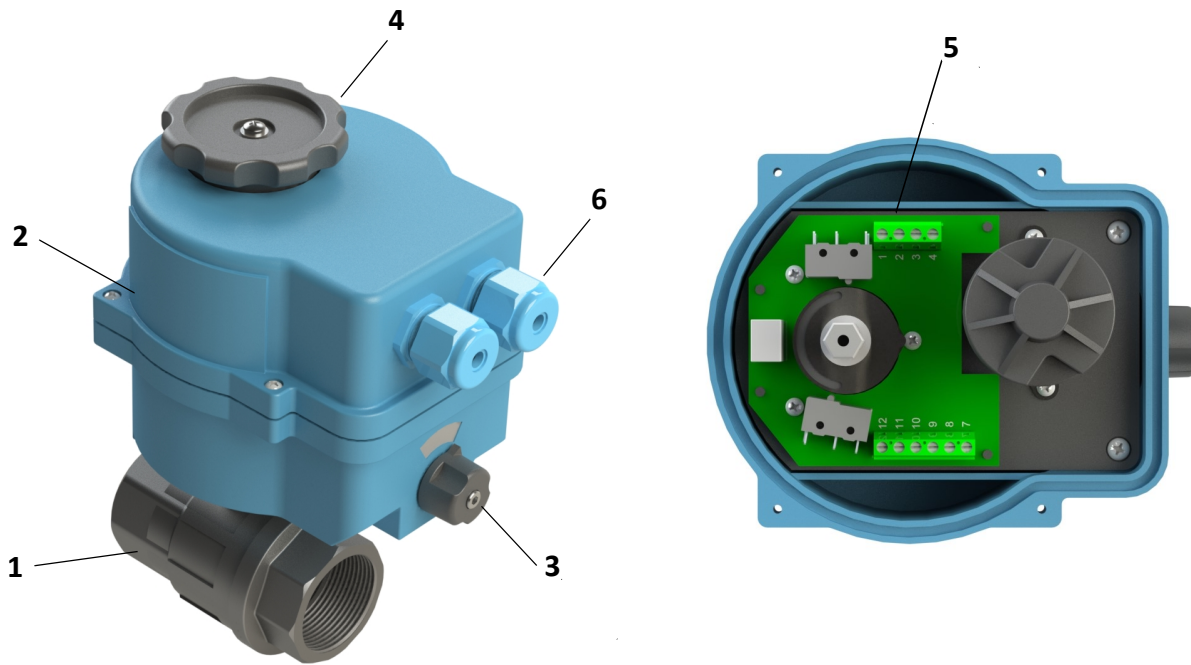

Item	Description	Item	Description
1	Valve Body	5	Wiring Connections - Terminal F <ul style="list-style-type: none"> • Terminal 1 - Closing • Terminal 2 - Com • Terminal 3 - Opening • Terminal 4 - Not Used
2	Valve Actuator	6	Wiring Entry Fittings
3	Valve Operation Selector		
4	Actuator Manual Control Knob		

Controls, Indicators, and Connections

Figure 1B: Motorized Stainless 2-Way Valves (1 1/2" and larger) Controls, Indicators, and Connections

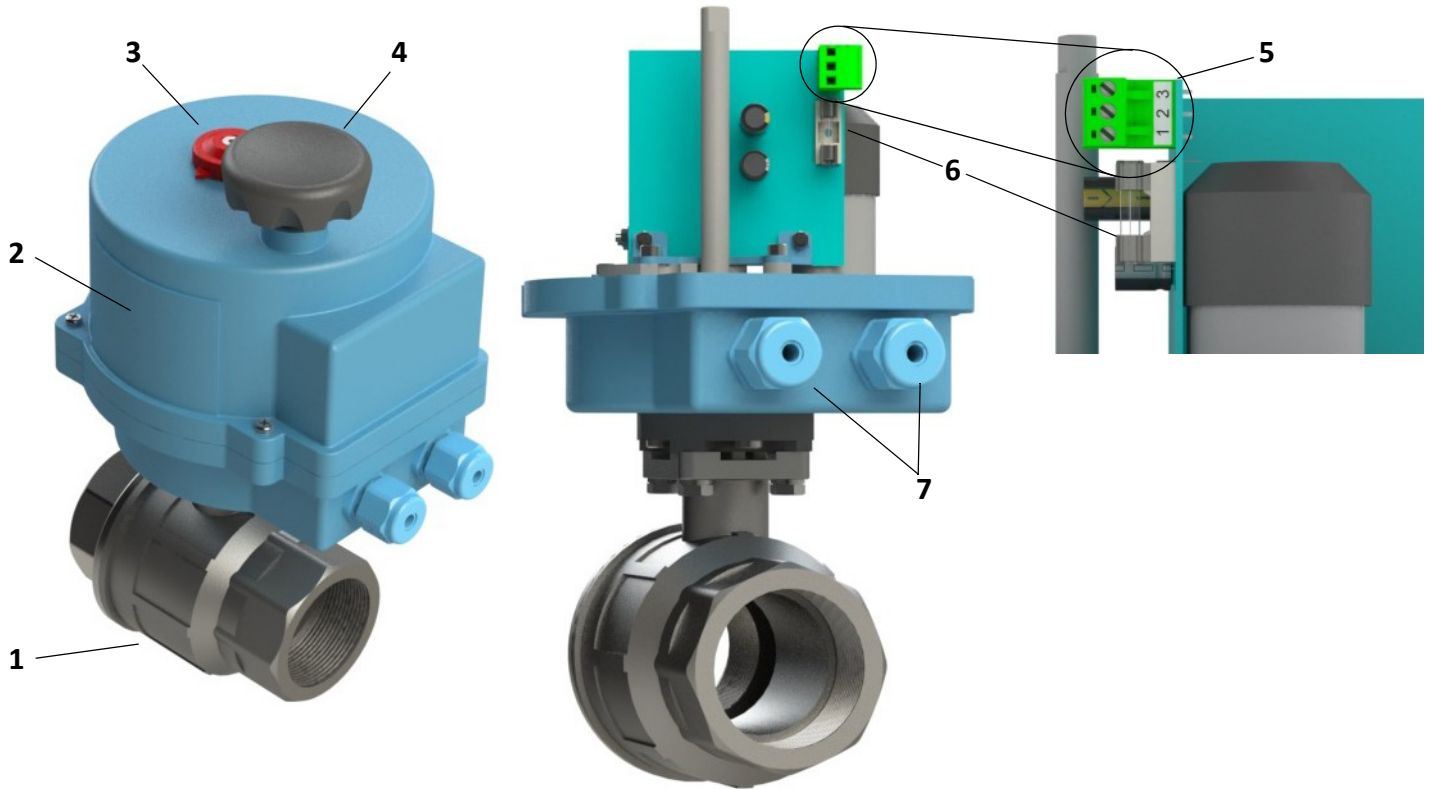

Item	Description	Item	Description
1	Valve Body	5	Wiring Connections - Terminal F <ul style="list-style-type: none"> • Terminal 1 – Closing • Terminal 2 – COM • Terminal 3 – Opening
2	Valve Actuator	6	Fuse (2A)
3	Valve Position Indicator	7	Wiring Entry Fittings
4	Actuator Manual Control Knob		

Detailed Operation

Overview

The motorized stainless 2-way valves works with any domestic hot water system in conjunction with the ETV Platinum as a safety shutdown valve. The motorized valves can also be used as a 2-way shut off valve with 100% closure in many other applications such as a boiler isolation valve.

Actuator Status LEDs

2-way Motorized Valve Actuator (1 1/2" and larger) and all valve sizes with battery backup actuators have three status LED's

LED	Description
Green	Lights when power is provided to the actuator.
Yellow	Flashes when the actuator is in "working" mode. The flash speed indicates the actuator power source. <ul style="list-style-type: none"> • Slow: Voltage is supplied on terminal block F. • Fast: Voltage is supplied from an optional battery backup.
Red	Lights when the actuator is in fault mode due to one of the following conditions: <ul style="list-style-type: none"> • Unblock operation failed, actuator exceeded torque limit. • Power supply voltage is under the minimum allowance. • Exceeded the maximum working time of a single operation / actuator timed out.

Battery Backup - Optional

Actuators equipped with the optional built-in battery backup will CLOSE automatically in the event of a loss of power. Any OPEN operation that is currently in progress will be interrupted.

The actuator returns to normal automatic operation when power is restored.

The battery backup power board contains a Red status LED that displays the level of charge of the battery

- **Fast Flashing:** the battery is not connected to the power supply board or the battery is charging;
- **Light ON:** the battery is not charge at a nominal value and it could not guarantee a complete safety operation
- **Light OFF:** the battery is charged at the nominal value;

The LED display is correct if the battery is not deteriorated or damaged.

Actuator Manual Operation for valves 1 1/4" and smaller

Motorized valves can be manually operated during power outages or when servicing the equipment.

CAUTION

DO NOT manually operate the valve when power is supplied to the actuator. Manually operating the valve while the controller is also positioning the valve may result in damage to the equipment. Only manually operate the valve when power has been removed from the actuator.

1. Ensure power has been removed from the valve actuator.
2. Turn the operation selector (2) from AUTO to MAN
3. Rotate the handwheel (1) to manually position the valve to the desired position.
4. The actuator does not have a valve position indicator to assist in determining the current position of the valve so the valve can only be fully OPEN or fully CLOSED.

CLOCKWISE rotation closes the valve
COUNTER-CLOCKWISE rotation opens the valve

5. To return the actuator back into service, turn the operation selector back to AUTO and restore power back to the actuator.

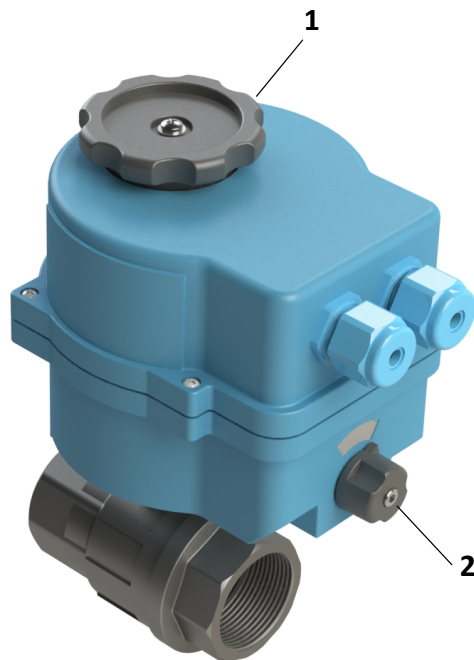

Actuator Manual Operation for valves 1 1/2" and larger

NOTE: This section applies to all valve sizes with battery backup actuators

Motorized valves can be manually operated during power outages or when servicing the equipment.

⚠ CAUTION

DO NOT manually operate the valve when power is supplied to the actuator. Manually operating the valve while the controller is also positioning the valve may result in damage to the equipment. Only manually operate the valve when power has been removed from the actuator

1. Ensure power has been removed from the valve actuator.
2. Press down on the actuator manual control knob (1) and rotate slightly to engage the valve stem to the knob.
NOTE: If the manual control knob is not fully engaged with the valve stem can result in damage to the manual control knob.
3. While continuing to press down on the actuator manual control knob, turn the knob until the valve is in the desired position.
 The valve position indicator (2) shows the current position of the valve.
4. When the valve is in the desired position, release pressure on the manual control knob.
 The knob is disengaged from the valve stem and the actuator returns to automatic positioning operation.
5. Return the valve back to service by restoring power to the actuator.

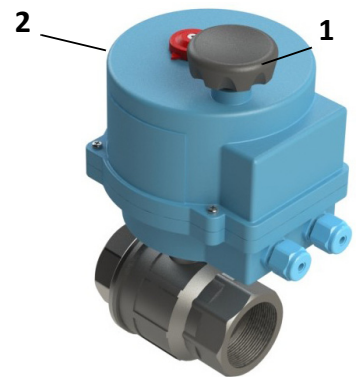

Maintenance

Type	Notes
Lubrication	The valve and actuator do not require any formal maintenance to operate. The internal lubrication of the actuator is sufficient for the life of the actuator.
Cleaning	Any cleaning of the actuator external enclosure should be done with a light detergent with a low level of chemical aggressiveness.
Battery Testing	Actuators with Battery Backup Only It is recommended that the actuator battery backup annually to ensure proper operation. To test the battery backup: <ol style="list-style-type: none"> 1. Remove power from the actuator. 2. Observe the actuator. Ensure the actuator closes the valve. NOTE: Contact Heat-Timer for information on replacing the battery, if necessary.

Specifications

Actuator Specifications

Valve Model	Voltage Input	Absorbed Current	Absorbed Power	Temp. Rating	Working Time	Max. Torque	Limit Switches	Battery Backup Option
1/2"	24Vac	0.6A	15 VA	-4°F to 131°F	10 sec.	133 in-lbs	(2) SPDT 1A @250	Yes
3/4"								
1"								
1 1/4"								

Dimensions (inches)								Heat-Timer P/N	
A	B	C	D	E	F	G	H	With Battery Backup	No Battery Backup
1/2	9.36	8.68	6.18	7.48	2.38	5.1	2.63	920550-00	920540-00
3/4	9.59	8.76	6.18	7.48	2.38	5.1	3.07	920551-00	920541-00
1	10.16	9.15	6.18	7.48	2.38	5.1	3.54	920552-00	920542-00
1 1/4	10.56	9.29	6.18	7.48	2.38	5.1	3.93	920553-00	920543-00

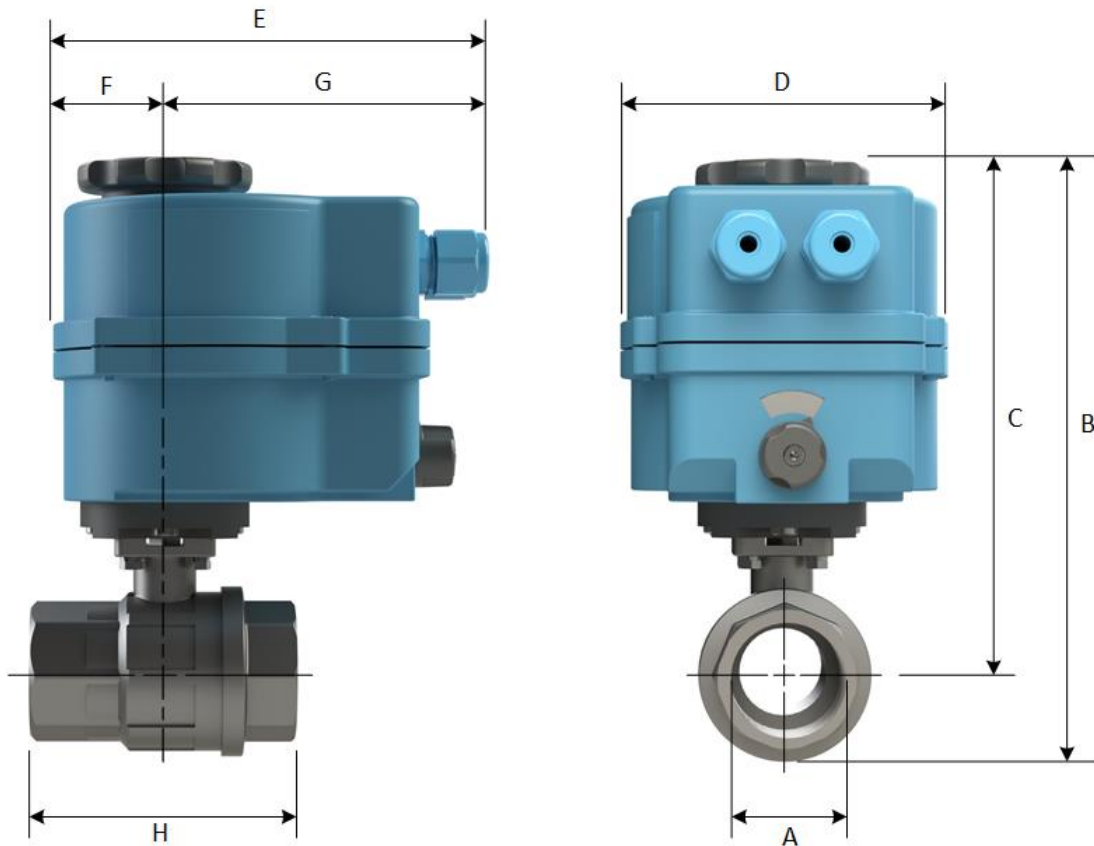

Figure 2A: Valve Body and Actuator Dimensions

Specifications

Actuator Specifications

Valve Model	Voltage Input	Absorbed Current	Absorbed Power	Temp. Rating	Working Time	Max. Torque	Limit Switches	Battery Backup Option
1 1/2"	24Vac	1.0–0.7A	24–17 VA	-4°F to 131°F	8 sec.	266 in-lbs	(2) SPDT 1A @250	Yes
2"					27 sec.	975 in-lbs		
2 1/2"		1.0–0.7A	24–17 VA		27 sec.	975 in-lbs		
3"		1.0–0.7A	24–17 VA		27 sec.	975 in-lbs		

Dimensions (inches)								Heat-Timer P/N	
A	B	C	D	E	F	G	H	With Battery Backup	No Battery Backup
1 1/2	11.4	9.88	6.18	7.48	2.38	5.1	4.4	920554-00	920544-00
2	12.15	10.24	6.18	7.48	2.38	5.1	5.31	920555-00	920545-00
2 1/2	15.06	12.74	7.28	8.43	2.66	5.77	6.32	920556-00	920546-00
3	16.51	13.77	8.31	9.33	3.31	6.02	7.01	920557-00	920561-00

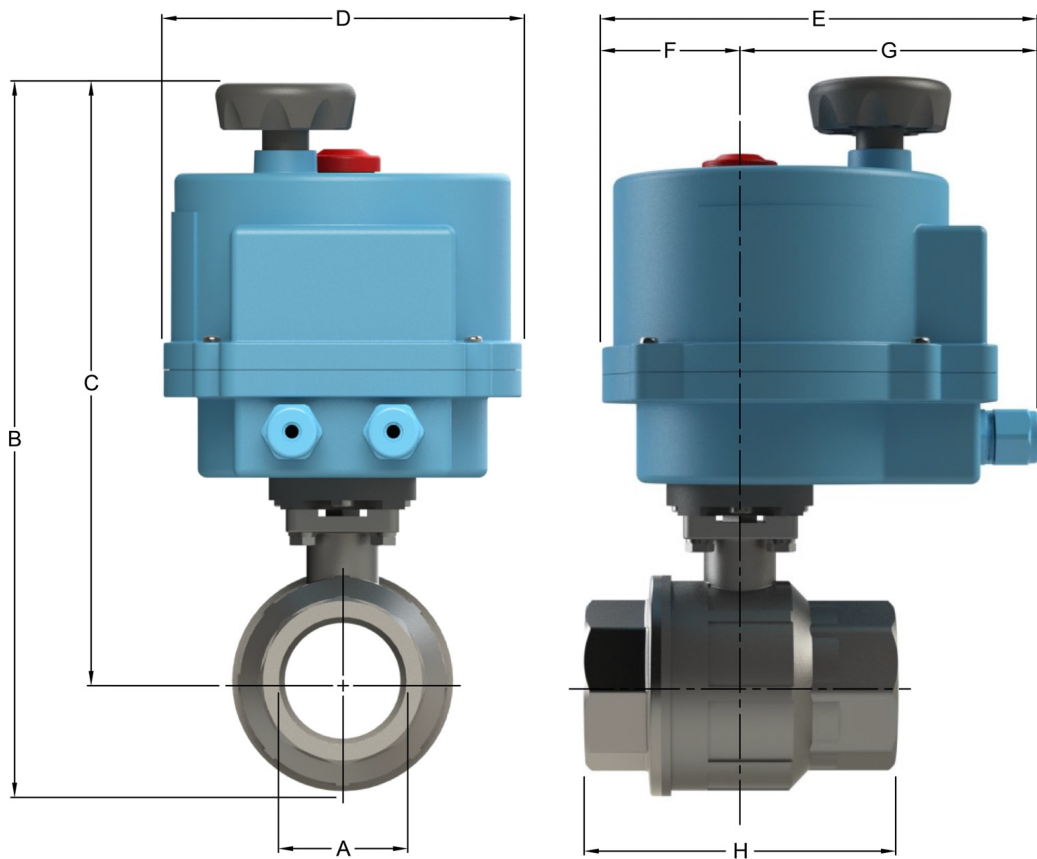

Figure 2B: Valve Body and Actuator Dimensions

Installation Instructions

The installation process for Motorized Stainless 2-Way Valves consists of the following basic steps:

1. Initial installation (see “Design Considerations” on page 11).
2. Installing the valve body (see page 12).
3. Wiring the actuator (see page 13).

Supplied Materials

The following materials are supplied with the control module:

- Motorized Stainless 2-Way Valve
- Hex "L" Key (p/n 200240-025)
- 24Vac Transformer (p/n 210006-00)
- Installation and Operation Manual (p/n 059434-00)
- Warranty Card (p/n 059115-00)

Required Materials (Not Supplied)

The following materials/tools are required for installation, but are not supplied:

- General tool kit (screwdrivers, wire strippers, power drill, etc.)
- 18 AWG cable (Heat-Timer p/n 703001-01 or equivalent #18/2 cable)

Design Considerations

When installing the system, certain design considerations must be taken into account. These include:

- All piping, including the piping of the valve body, must meet or exceed all applicable local, state, and/or federal guidelines, codes, regulations, and laws.
- Support all piping using hangers. **DO NOT** support piping by the unit or its components.
- Use isolation valves to isolate system components.
- Use unions to allow for servicing and, if required, removal of the valve and other components.
- Include drain valves to assist in servicing of the valve.
- Use a generous amount of pipe thread sealant. **DO NOT** use pipe thread tape. When using the valve in a domestic water application, ensure the thread sealant is compliant with domestic water application and meets NSF 61 requirements.

Installing the Valve Body

CAUTION

Use a two-wrench method (using one wrench to prevent the valve body from turning or twisting) when tightening piping onto the valve body connections. Failure to support the valve body in this manner may cause damage to the valve body or the actuator.

1. Ensure all debris (dirt, metal shavings, etc.) is flushed from the piping system before installing the valve body.
2. Ensure all service clearances are met. See “Actuator Specifications” valve and actuator assembly dimensions on page 8.

NOTE: The installation should account for an additional clearance of 4 – 6" (101.6mm – 152.4mm) above the actuator. This space is needed to allow for the manual operation of the actuator. Refer to “Actuator Manual Operation” on page 6.

3. Install the valve body while observing the following precautions:
 - The preferred orientation of the valve stem and actuator is upright (vertically). However, where space restrictions dictate, the valve assembly can be mounted diagonally or horizontally (see Figure 3).
 - **DO NOT** install motorized valves upside down. Doing so can stress the valve stem.

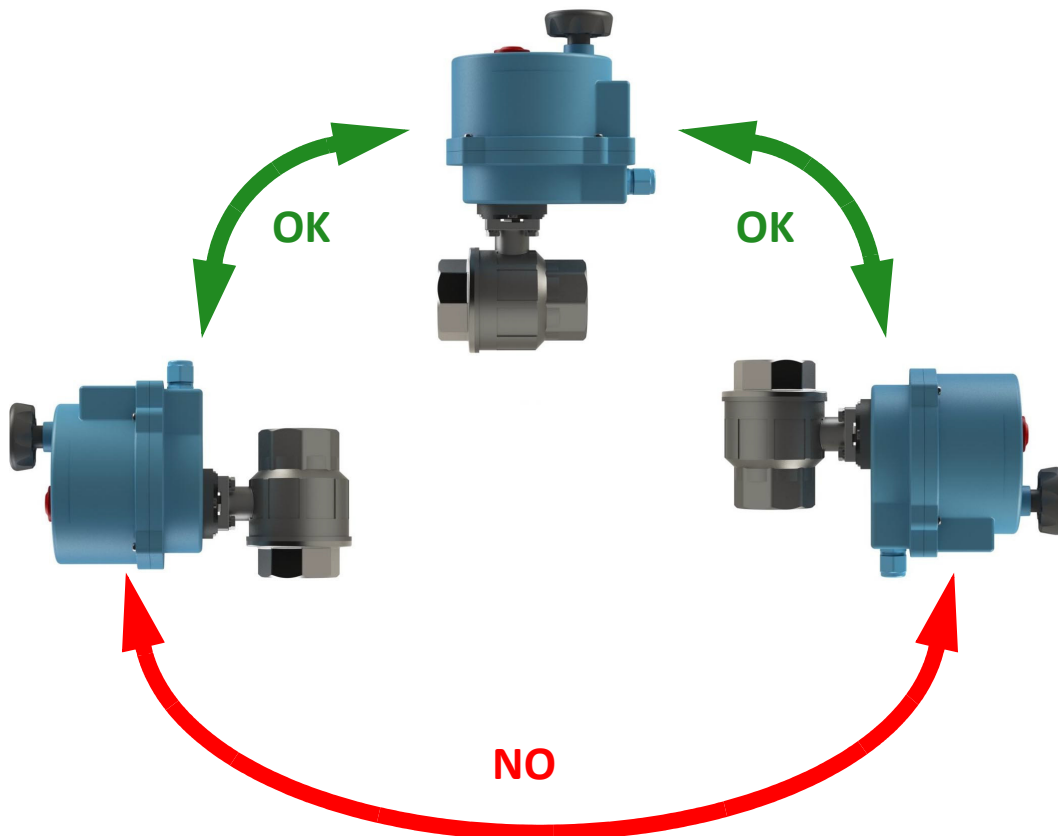

Figure 3: Acceptable Valve Body and Actuator Orientation

Wiring the Actuator

Mounting the Actuator Power Transformer

NOTE: Actuators must be powered using the provided 24Vac transformer(s). For configurations where a control device is operating two actuators in series, a single transformer can be used to power both actuators. If a control device is operating two actuators in parallel, external double-throw relays and two transformers (one for each actuator) must be installed.

1. Select an appropriate location to mount the 24Vac power transformer(s). The location must meet the following minimum requirements:
 - The location should be within close proximity of the actuator to reduce wiring length.
 - The mounting surface should be flat and strong enough to hold the weight of the transformer.
 - **DO NOT** mount the device in a location where it will be exposed to extreme heat, cold, humidity, or moisture.
2. Secure the transformer(s) to the mounting surface using two screws (not supplied).

Actuator Wiring

For valve sizes 1 1/4" or smaller - reference pages 14 to 16

For valve sizes 1 1/2" or larger - reference pages 17 to 19

For all valve sizes with the optional battery backup - reference pages 17 to 19

Removing the Actuator Cover 1 1/4" Valves and smaller

1. De-energize the circuit that will provide power to the actuator transformer by turning off the appropriate circuit breaker.
2. Remove the actuator wiring enclosure:
 - a. Remove the Manual Control Knob screw (1).
 - b. Remove the four enclosure cover screws (2).



CAUTION

Use care when removing the actuator upper cover to avoid damaging the internal electronic parts.

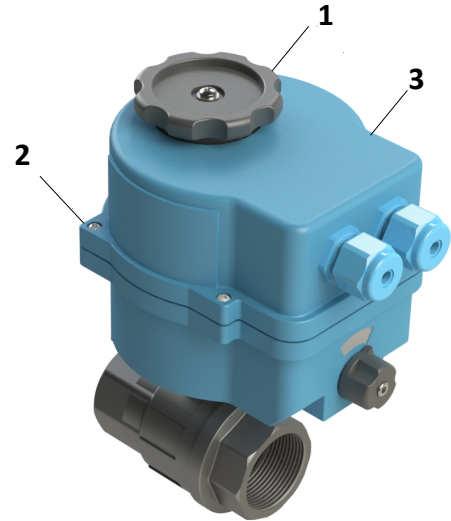

- c. Remove the actuator upper cover (3).

Power Input Wiring



WARNING

ELECTRICAL SHOCK HAZARD! For your safety, to avoid the risk of electric shock, disconnect electrical power to the device before servicing or making any electrical connections. **DO NOT** re-connect electrical power until **ALL** wiring to the actuator is completed. Failure to do so may result in severe personal injury or death.

All wiring must meet or exceed all applicable local, state, and/or federal guidelines, codes, regulations, and laws.

1. De-energize the circuit that will provide power to the actuator transformer by turning off the appropriate circuit breaker.
2. Route the 24Vac wiring from the transformer through one of the actuator electrical entry fittings (1).
3. Route the 24Vac wiring within the actuator to Terminal Block F (4).
4. Connect the wiring to the appropriate terminal based on the application and control being used. See “**Connecting the Actuator to an ETV Platinum Plus Control**” on page 15.

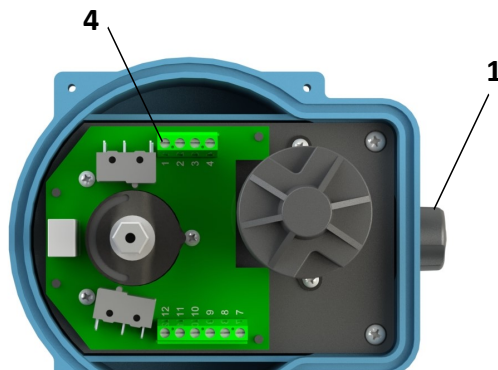

Connecting the Actuator (1 1/4" and smaller) to an ETV Platinum Plus Control

Refer to the following diagram when connecting actuators to an ETV Platinum Plus control.

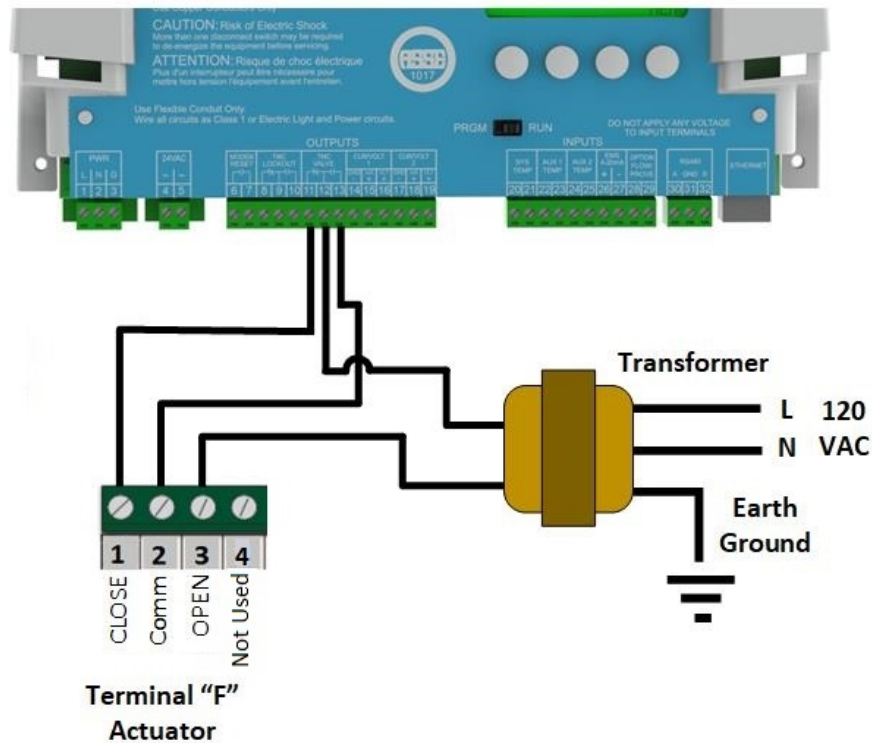

Figure 4A: Valve Actuator (1 1/4" and smaller) Wiring Diagram – ETV Platinum Plus Control

WARNING

ELECTRICAL SHOCK HAZARD! For your safety, to avoid the risk of electric shock, disconnect electrical power to the device before servicing or making any electrical connections. **DO NOT** re-connect electrical power until **ALL** wiring to the actuator is completed. Failure to do so may result in severe personal injury or death.

All wiring must meet or exceed all applicable local, state, and/or federal guidelines, codes, regulations, and laws.

1. Connect one of the 24Vac transformer outputs to the actuator Common terminal (3) on Terminal Block F.
2. Connect the second 24Vac transformer output to the TMC Valve Common terminal (12) on the ETV Platinum Plus.
3. Connect the TMC Valve normally closed (NC) terminal (11) to the actuator CLOSE terminal (1) on Terminal Block F.
4. Connect the TMC Valve normally open (NO) terminal (13) to the actuator OPEN terminal (2) on Terminal Block F.
5. Continue with **"Completing the Wiring"** on page 16.

Completing the Wiring

1. After all wiring is complete, install the actuator wiring enclosure:

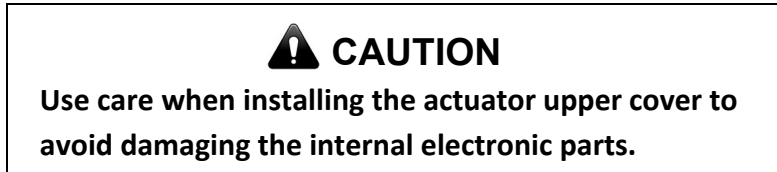

- a. Place the actuator upper cover (3) on the actuator.
 - b. Secure the upper cover with the four enclosure cover screws (2).
 - c. Secure the position indicator with the screw (1).
2. Restore power to the circuit powering the actuator transformer.

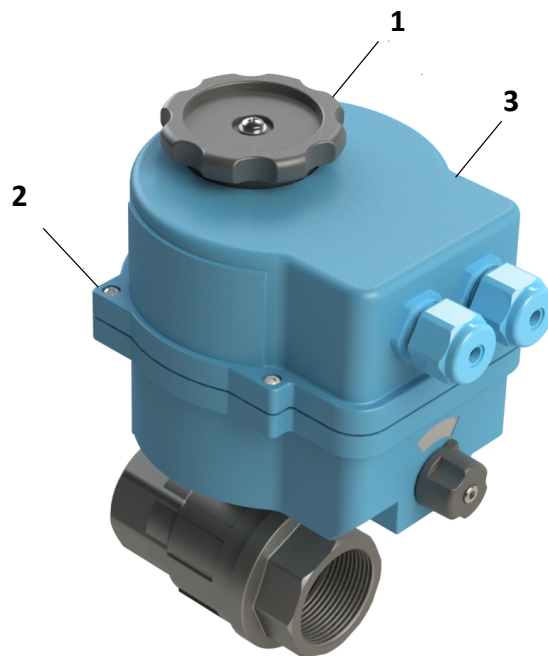

Removing the Actuator Cover 1 1/2" Valves and larger

1. De-energize the circuit that will provide power to the actuator transformer by turning off the appropriate circuit breaker.
2. Remove the actuator wiring enclosure:
 - a. Remove the position indicator screw (1).
 - b. Remove the position indicator (2).
 - c. Remove the four enclosure cover screws (3).

CAUTION

Use care when removing the actuator upper cover to avoid damaging the internal electronic parts.

- d. Remove the actuator upper cover (4).



Power Input Wiring

WARNING

ELECTRICAL SHOCK HAZARD! For your safety, to avoid the risk of electric shock, disconnect electrical power to the device before servicing or making any electrical connections. **DO NOT** re-connect electrical power until **ALL** wiring to the actuator is completed. Failure to do so may result in severe personal injury or death.

All wiring must meet or exceed all applicable local, state, and/or federal guidelines, codes, regulations, and laws.

1. De-energize the circuit that will provide power to the actuator transformer by turning off the appropriate circuit breaker.
2. Route the 24Vac wiring from the transformer through one of the actuator electrical entry fittings (1).
3. Route the 24Vac wiring within the actuator to Terminal Block F (2).
4. Connect the wiring to the appropriate terminal based on the application and control being used. See “**Connecting the Actuator to an ETV Platinum Plus Control**” on page 18.

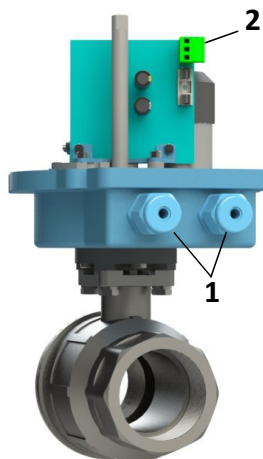

Connecting the Actuator to an ETV Platinum Plus Control

Refer to the following diagram when connecting actuators to an ETV Platinum Plus control.

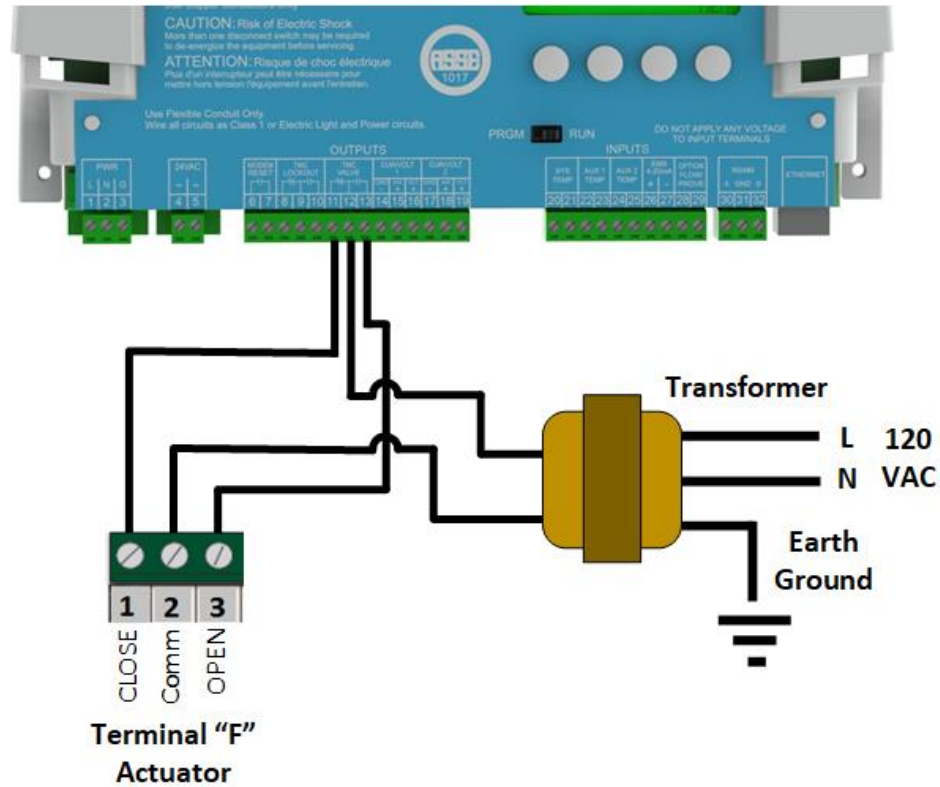

Figure 4B: Valve Actuator Wiring Diagram – ETV Platinum Plus Control

⚠ WARNING

ELECTRICAL SHOCK HAZARD! For your safety, to avoid the risk of electric shock, disconnect electrical power to the device before servicing or making any electrical connections. **DO NOT** re-connect electrical power until **ALL** wiring to the actuator is completed. Failure to do so may result in severe personal injury or death.

All wiring must meet or exceed all applicable local, state, and/or federal guidelines, codes, regulations, and laws.

1. Connect one of the 24Vac transformer outputs to the actuator Common terminal (2) on Terminal Block F.
2. Connect the second 24Vac transformer output to the TMC Valve Common terminal (12) on the ETV Platinum Plus.
3. Connect the TMC Valve normally closed (NC) terminal (11) to the actuator CLOSE terminal (1) on Terminal Block F.
4. Connect the TMC Valve normally open (NO) terminal (13) to the actuator OPEN terminal (3) on Terminal Block F.
5. Continue with “**Completing the Wiring**” on page 19.

Completing the Wiring

1. After all wiring is complete, install the actuator wiring enclosure:

 **CAUTION**

Use care when installing the actuator upper cover to avoid damaging the internal electronic parts

- a. Place the actuator upper cover (4) on the actuator.
 - b. Secure the upper cover with the four enclosure cover screws (3).
 - c. Install the position indicator (2).
 - d. Secure the position indicator with the screw (1).
2. Restore power to the circuit powering the actuator transformer.



Troubleshooting

Symptom	Possible Cause	Recommended Action(s)
Actuator does not open.	No power to the actuator or control.	<ul style="list-style-type: none"> • Ensure there is power between actuator COMMON terminal and OPEN terminal. • Check the 2A fuse on the actuator circuit board. Replace the fuse if necessary. • Ensure the ETV Platinum Plus control has power. If the control is in an alarm condition, the control should close the valve as long as there is power on the control TMC terminals, or on loss of power if the battery backup option is installed.
Actuator does not close.	No power to the actuator or control.	<ul style="list-style-type: none"> • Ensure there is power between actuator COMMON terminal and CLOSE terminal. • Check the 2A fuse on the actuator circuit board. Replace the fuse if necessary. • Ensure the ETV Platinum Plus control has power. If the control is in an alarm condition, only the battery backup option will close the valve on loss of power.

NOTE: The 2A fuse only applies to valve actuators 1 1/2" & larger and actuators with battery backup.

Notes

Notes

Notes

WARRANTY

WARRANTIES AND LIMITATIONS OF LIABILITY AND DAMAGE: Heat-Timer Corporation warrants that it will replace, or at its option, repair any Heat-Timer Corporation manufactured product or part thereof which is found to be defective in material workmanship within one year from the date of installation only if the warranty registration has been completed online within 30 days of the date of installation. Damages to the product or part thereof due to misuse, abuse, improper installation by others or caused by power failure, power surges, fire, flood or lightning are not covered by this warranty. Any service, repairs, modifications or alterations to the product not expressly authorized by Heat-Timer Corporation will invalidate the warranty. Batteries are not included in this warranty. This warranty applies only to the original user and is not assignable or transferable. Heat-Timer Corporation shall not be responsible for any maladjustments of any control installed by Heat-Timer Corporation. It is the user's responsibility to adjust the settings of the control to provide the proper amount of heat or cooling required in the premises and for proper operation of the heating or cooling system. Heat-Timer Corporation shall not be required to make any changes to any building systems, including but not limited to the heating system, boilers or electrical power system, that is required for proper operation of any controls or other equipment installed by Heat-Timer Corporation or any contractor. Third Party products and services are not covered by this Heat-Timer Corporation warranty and Heat-Timer Corporation makes no representations or warranties on behalf of such third parties. Any warranty on such products or services is from the supplier, manufacturer, or licensor of the product or service.

THE FOREGOING IS IN LIEU OF ALL OTHER WARRANTIES, EXPRESS OR IMPLIED AND HEAT-TIMER CORPORATION SPECIFICALLY DISCLAIMS ANY AND ALL WARRANTIES OF MERCHANTABILITY FOR A PARTICULAR PURPOSE. UNDER NO CIRCUMSTANCES SHALL HEAT-TIMER CORPORATION, ITS AUTHORIZED REPRESENTATIVES, AFFILIATED OR SUBSIDIARY COMPANIES BE LIABLE FOR SPECIAL, CONSEQUENTIAL, PUNITIVE, INDIRECT OR INCIDENTAL DAMAGES, EXCEPT AS SPECIFICALLY STATED IN THESE TERMS AND CONDITIONS OF SALE. THE SOLE REMEDY WITH RESPECT TO ANY PRODUCT OR PART SOLD OR INSTALLED BY HEAT-TIMER CORPORATION SHALL BE LIMITED TO THE RIGHT TO REPLACEMENT OR REPAIR F.O.B. FAIRFIELD, NJ. HEAT-TIMER CORPORATION SHALL NOT BE LIABLE OR RESPONSIBLE FOR LOSS OR DAMAGE OF ANY KIND RESULTING FROM DELAY OR INABILITY TO DELIVER FOR ANY REASON, INCLUDING BUT NOT LIMITED TO FIRE, FLOOD, LIGHTNING, POWER FAILURE OR SURGES, UNAVAILABILITY OF PARTS, STRIKES OR LABOR DISPUTES, ACCIDENTS AND ACTS OF CIVIL OR MILITARY AUTHORITIES. HEAT-TIMER CORPORATION MAKES NO REPRESENTATIONS OR WARRANTIES THAT THE PRODUCTS ARE FREE OF RIGHTFUL CLAIMS OF ANY THIRD PARTY FOR INFRINGEMENT OF PROPRIETARY RIGHTS. HEAT-TIMER CORPORATION'S AGGREGATE LIABILITY UNDER THESE TERMS AND CONDITIONS OF SALE SHALL IN NO EVENT EXCEED THE PURCHASE PRICE OF THE PRODUCT.

ICMS Internet Access Service and ICMS Data Service are not provided as part of the sale of any RINet control unless specifically included on the invoice. These services must be purchased separately. The Internet Access provider may retain ownership of any modems provided as part of Internet Access Service. Such modems shall be returned to the Internet provider at the time of termination of such Internet Access Service, otherwise the Purchaser may be charged for the price of such modem.

Rev. 100114

