

# Installation and Operation Manual

# Multi-MOD Platinum

Multi-Boiler Modulating Control for Hydronic and Steam Applications with Space Feedback

Modulation Signal: 135Ω, 4-20mA, or Voltage

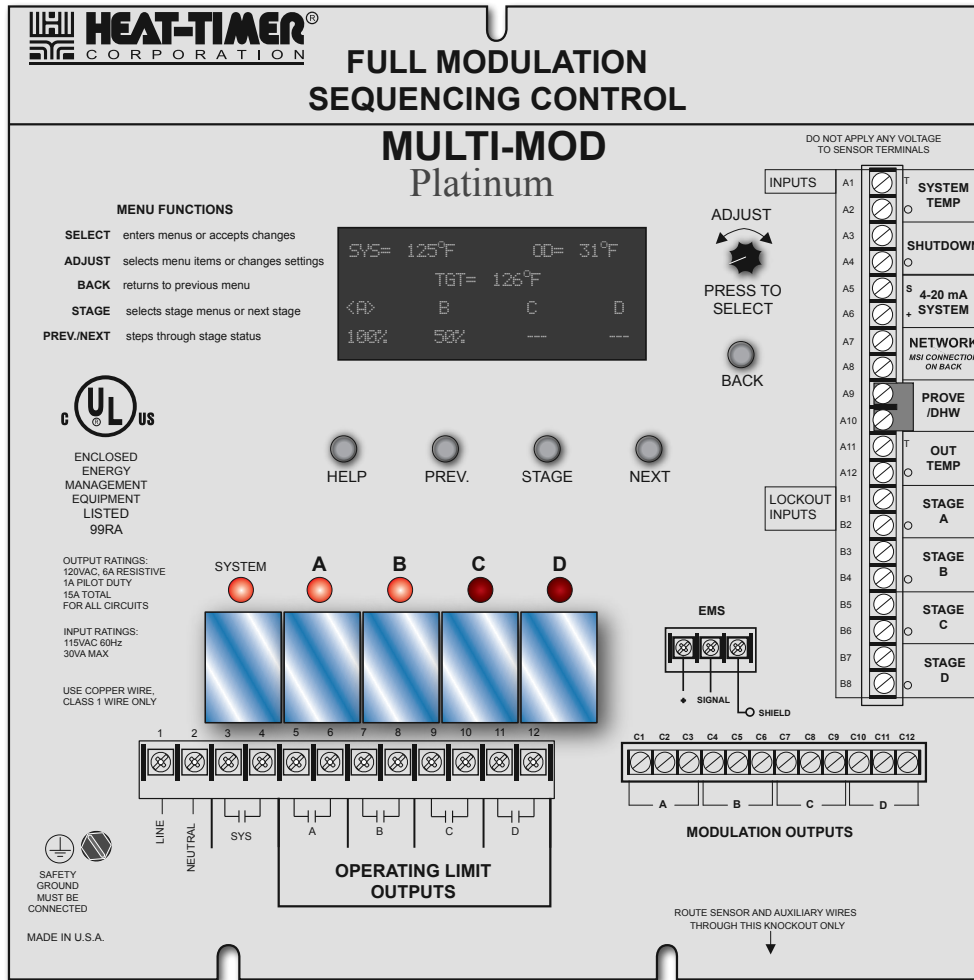

## ⚠ WARNING

This Heat-Timer control is strictly an operating control; it should never be used as a primary limit or safety control. All equipment must have its own certified limit and safety controls required by local codes. The installer must verify proper operation and correct any safety problems prior to the installation of this Heat-Timer control.

# CONTENT

CONTENT . . . . .	2	Outdoor Reset Settings . . . . .	32
MULTI-MOD PLATINUM OVERVIEW . . . . .	3	Reset Ratio . . . . .	33
Standard Features . . . . .	3	Target Offset . . . . .	33
Optional Features . . . . .	4	Minimum Target . . . . .	33
MODULATION CONCEPT . . . . .	4	Maximum Target . . . . .	34
UNDERSTANDING OPERATION CONCEPT . . . . .	5	System Run-On . . . . .	34
Reset Ratio/Outdoor Reset . . . . .	5	STAGE MODULATION . . . . .	36
Space Feedback Concept . . . . .	6	Gain . . . . .	36
INITIAL PILOT PROGRAM . . . . .	7	Purge Delay . . . . .	36
Make Sure You Have the Right Control . . . . .	7	Lag Delay . . . . .	37
MULTI-MOD PLATINUM FUNCTION CHART . . . . .	8	Standby Time . . . . .	37
MULTI-MOD PLATINUM BACK CHART . . . . .	9	Last-Stage-Hold . . . . .	37
EXTENSION FUNCTION CHART . . . . .	10	Soft-off Delay . . . . .	37
EXTENSION BACK CHART . . . . .	11	Modulation Speed . . . . .	38
INSTALLATION . . . . .	12	Lead Stage Rotation . . . . .	38
Mounting the Enclosure . . . . .	12	Lead Stage . . . . .	38
Activate the Battery . . . . .	12	Lead Auto Rotate . . . . .	38
Remote Communication Wiring . . . . .	12	STAGE SETTINGS . . . . .	39
BACnet MSTP or Modbus RS485 Wiring . . . . .	12	Stage Menu . . . . .	39
Internet or BACnet IP Ethernet Wiring . . . . .	13	Moving Around the Stages Menus . . . . .	39
Input Wiring . . . . .	17	Mode . . . . .	39
Outdoor sensor . . . . .	17	Ignition % . . . . .	40
System Sensor . . . . .	17	Modulation Start . . . . .	40
4-20mA Temperature Sensor Wiring . . . . .	18	Copy Settings (Stage A Only) . . . . .	41
Setback Wiring . . . . .	20	SCHEDULES MENU . . . . .	42
Interfacing to MPC . . . . .	20	Schedules . . . . .	42
Interfacing to HWR . . . . .	20	Shift . . . . .	42
Connecting Multi-MOD Platinum to Extensions . . . . .	21	Day/Night Schedule . . . . .	43
External Set Point Wiring . . . . .	22	Copy Schedule . . . . .	44
Connecting Internet communication . . . . .	22	Set Date and Time . . . . .	44
Connecting BACnet Communication . . . . .	22	Vacation Schedule Setting . . . . .	44
Connecting MODBUS Communication . . . . .	22	COMMUNICATION MENU . . . . .	45
Network Sensors Wiring . . . . .	22	Internet Communication . . . . .	45
Modulating Output Card Installation . . . . .	23	Space Lockout . . . . .	45
DISPLAY . . . . .	23	Day and Night Target . . . . .	46
BUTTON FUNCTIONS . . . . .	23	Space Feedback Gain . . . . .	46
DISPLAY STAGE MODULATION STATUS . . . . .	24	BACnet Communication . . . . .	46
Display Messages . . . . .	24	Modbus Communication . . . . .	46
SYSTEM STARTUP MENU . . . . .	25	MAINTENANCE MENU . . . . .	47
SYSTEM STARTUP . . . . .	26	System and Outdoor Sensor Trim . . . . .	47
Sensor Type . . . . .	26	Stage Output Trim . . . . .	47
Sensor Type Table . . . . .	26	SECURITY . . . . .	48
System Temperature Sensor Type . . . . .	26	Password Enabled . . . . .	48
EMS Input Mode . . . . .	27	Password Change . . . . .	48
Stage Interface . . . . .	27	RESET CONTROL TO FACTORY DEFAULTS . . . . .	48
DHW Set Point . . . . .	29	TROUBLESHOOTING . . . . .	49
Sensor Fault . . . . .	29	SPECIFICATIONS . . . . .	51
Fast Cool Down . . . . .	30	Multi-MOD Platinum Specifications . . . . .	51
Day Light Saving . . . . .	30	Extension Module Specifications . . . . .	51
SYSTEM SETTINGS MENU . . . . .	31	WIRING DIAGRAMS . . . . .	52
SYSTEM SETTINGS . . . . .	32	WARRANTY . . . . .	58
Season . . . . .	32		
Set Point . . . . .	32		
Outdoor Cutoff Temperature . . . . .	32		

HT# 059299-00 A

# MULTI-MOD PLATINUM OVERVIEW

The Multi-MOD Platinum is a multi-boiler modulating control. It uses PID logic in addition to overlapping the lead and lag boiler modulation, its patent logic, to achieve a smooth modulation and efficient system performance. It is capable of modulating 4 on board boilers. When used with extensions panels it can connect to a total of 20 modulating boilers. Up to two external extensions can be used, each connecting to 8 modulating boilers. The Multi-MOD Platinum is used in a variety of applications including building heating and process applications.

## STANDARD FEATURES

<b>Heat or Cool:</b>	The Multi-MOD Platinum can operate in heating or cooling applications.
<b>Outdoor Reset or Set Point:</b>	When connected to a temperature sensor and an outdoor sensor, the Multi-MOD Platinum can change the target based on the outdoor temperature (Outdoor Reset) or it can modulate the boilers to maintain a fixed set point. See "Sensor Type" on page 26.
<b>Multiple Sensor Types:</b>	The Multi-MOD Platinum can operate in a temperature or pressure environment to maintain a set point. For high temperature applications it can connect to 4-20mA temperature sensors. See "Sensor Type" on page 26.
<b>Modulation signal:</b>	It accurately modulate motors using any of the 0-5V, 0-10V, 1-5V, 2-10V, 4-20 mA, or 0-135Ω modulating signals. It can also modulate a combination of boilers with different modulating signals. See "Output Type" on page 27.
<b>Setback Schedule:</b>	The Multi-MOD Platinum now has a built-in 7-day schedule. Each day has 4 day and 4 night time settings. See "Schedules" on page 42.
<b>External Setback:</b>	The Multi-MOD Platinum can accept setback input from external controls to lower the target Set Point. See "Setback Wiring" on page 20 and "Setback" on page 35.
<b>Boost:</b>	The Boost raises the building space temperature to day levels quicker. It does that by raising the target water temperature before the first day schedule. See "Boost and Early Shutdown" on page 34.
<b>Day/Night Shift:</b>	This feature allows the user to temporarily switch the control from Night Time settings to Day Time settings or visa versa. See "Shift" on page 42.
<b>Outdoor Cutoff:</b>	The outdoor sensor is used to turn all the outputs off whenever the outdoor temperature rises above the outdoor Cutoff value. See "Outdoor Cutoff Temperature" on page 32.
<b>Season:</b>	The Multi-MOD Platinum operation can be turned off during off-season using the Season setting. See "Season" on page 32.
<b>Rotation:</b>	The control has three modes of rotation: Manual, Last-On, or Automatic. The Automatic option rotates the stages based on time. See "Lead Stage Rotation" on page 38.
<b>Process or Normal Modulation:</b>	Use Normal (PID) logic for slow responding systems as in heating systems. Use Process in fast responding systems. See "Modulating Mode" on page 28.
<b>Standby Stages:</b>	Any stage can be set to be a standby boiler (backup boiler). A Standby boiler will only run after the rest of the boilers reach full fire and remain at it for the Standby Delay period. See "Standby Time" on page 37.
<b>Prove Input:</b>	This input checks for component status before activating any stage. It can be used to check the combustion air damper or flow switch status. See "Prove Wiring" on page 19.
<b>Shutdown Input:</b>	This input turns off the heating from a remote location. See "Shutdown Wiring" on page 18.
<b>System Output:</b>	This output can be used to activate a system pump, combustion air damper, or perform any other function that is required before any stage is activated.
<b>DHW Priority:</b>	The control offers multiple DHW Priority options. See "Prove/DHW Mode" on page 28.
<b>Connects to EMS:</b>	The Multi-MOD Platinum can accept a remote 4-20 mA set point signal. See "External Set Point Wiring" on page 22.
<b>Gain:</b>	The Gain adjusts the aggressiveness of the modulation. See "Gain" on page 36..
<b>Last Stage Hold:</b>	This feature is used primarily to reduce boiler short cycling. The Last Stage Hold maintains the system on longer and off longer. See "Last-Stage-Hold" on page 37.
<b>Password Security:</b>	The Multi-MOD Platinum is equipped with a password that is used to stop unauthorized user from changing any of the control settings. See "Security" on page 48.

## OPTIONAL FEATURES

- Internet Communication:** The Internet communication option gives remote access to the control from any computer with a web browser. The access is through Heat-Timer ICMS web site. Internet ready controls have the capability to connect to a large number of network sensors. These sensors can be space, temperature, pressure, oil tank levels, and many more. Furthermore, the Internet option adds history graphing, export reports to e-mail, and alarming that is delivered by e-mail, web, and text messaging. See "Internet Communication" on page 45.
- BACnet Communication:** The Multi-MOD Platinum can be upgraded to communicate over BACnet IP or MSTP networks. All Multi-MOD Platinum functions can be monitored from a remote location. See BACnet Communication Upgrade Manual.
- Modbus Communication:** The Multi-MOD Platinum can be upgraded to communicate over Modbus RTU networks. All Multi-MOD Platinum functions can be monitored from a remote location. See Modbus Communication Upgrade Manual.
- Space Feedback:** When the Multi-MOD Platinum is equipped with Internet communication, it can connect to a large number of wireless and wired space sensors. It uses the space average temperature to regulate the building heat for better comfort control and fuel savings. See "Space Feedback Concept" on page 6.

## MODULATION CONCEPT

The Multi-MOD Platinum modulates the boilers to achieve the smoothest operation and highest system efficiency. It does that by overlapping the lead and lag boiler operation. The concept depends on the Ignition % and the Modulation Start %.

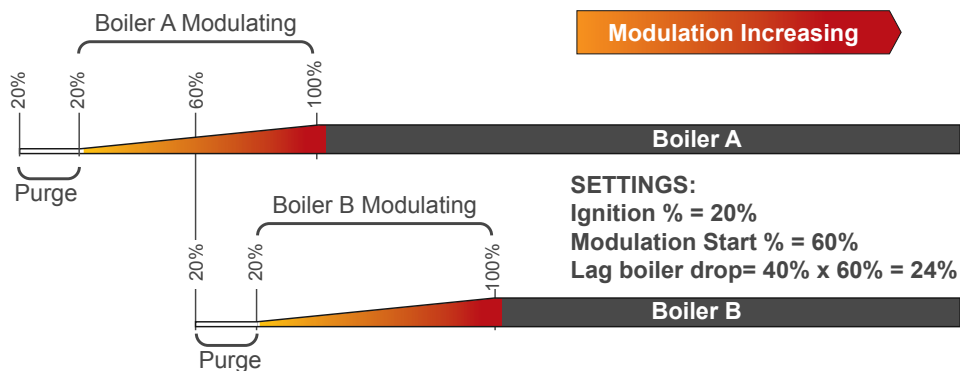

### Normal Modulation Increase

When the control needs to start heating, it activates the System output. In most cases, this output operates a system pump or a combustion air damper. Then, the control checks the safety components operation status by checking the Prove input for closure. If the Prove signal was shorted, the control starts the lead boiler Purge. Whenever a boiler is activated, it must first go through the Purge period. See "Purge Delay" on page 36. During Purge the control sets the boiler modulation to the lowest firing rate set by the Ignition %. See "Ignition %" on page 40. After the Purge ends, the control starts to modulate the lead boiler gradually. Whenever, the lead boiler reaches its Modulation Start %, the control starts the lag boiler Purge. See "Modulation Start" on page 40. After the lead boiler reaches its full capacity, the lag boiler may start its upward modulation. This process repeats for each additional lag boiler or until the system is satisfied.

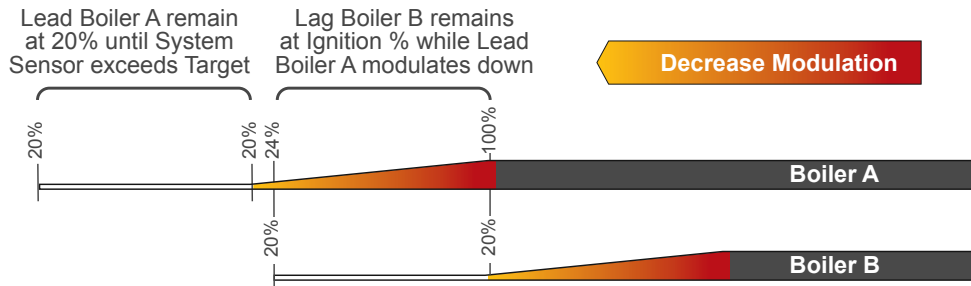

### Normal Modulation Decrease

When the load is reduced, the control will gradually decrease the lag boiler's modulation until it reaches its lowest firing %. The lag boiler will remain at the Ignition % while the control is reducing the lead boiler's modulation. When the lead boiler reaches 40% of the Modulation Start %, the control turns off the lag boiler.

## UNDERSTANDING OPERATION CONCEPT

The Multi-MOD Platinum has multiple operating modes that satisfy most hydronic or steam systems. When used to control a hydronic system, it can change the target Set Point based on outdoor temperature (Outdoor Reset) or it can modulate its stages to achieve a fixed Set Point.

In Outdoor Reset, the Multi-MOD Platinum controls a hot water heating system to provide a building with comfortable and even heat levels. It varies the temperature of the circulating heating water in response to changes in the outdoor temperature. The heating water temperature is controlled through the modulation of the stages.

The Multi-MOD Platinum also controls the system-circulating pump with an adjustable Outdoor Cutoff. When the outdoor temperature is above Outdoor Cutoff, the pump is off and no heating water is circulated through the system. When the outdoor temperature drops below the Outdoor Cutoff, the system pump output is activated and the heating water circulates through the system. The temperature of the heating water is controlled by the Reset Ratio, Offset, Minimum Target, Maximum Target, and the outdoor temperature.

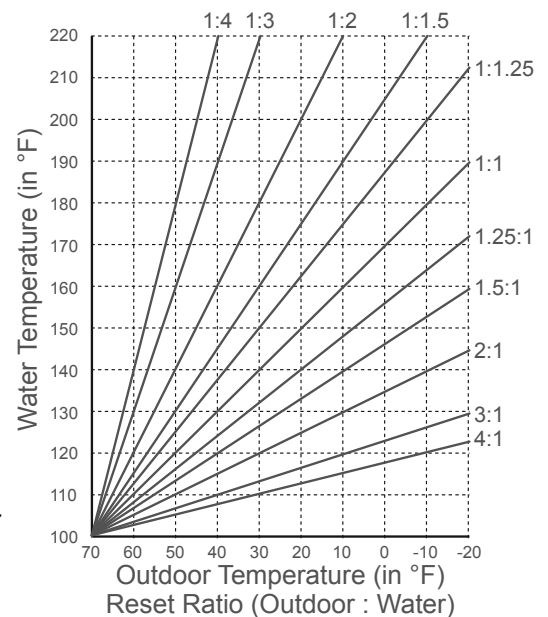

### Reset Ratio Curves

## RESET RATIO/OUTDOOR RESET

When a building is being heated, heat escapes through the walls, doors, and windows to the colder outside air. The colder the outside temperature, the more heat escapes. If you can input heat into the building at the same rate that it is lost out of the building, then the building temperature will remain constant. The Reset Ratio is an adjustment that lets the building achieve this equilibrium between heat input and heat loss. Outdoor reset is the most efficient way a building can be heated.

The starting reset ratio for most systems is the 1.00 (OD):1.00 (SYS) (Outdoor Temperature : Heating Water Temperature) ratio. This means that for every degree the outdoor temperature drops, the temperature of the heating water will increase one degree. The starting point of the ratio is adjustable, but comes factory set to 70°F Outdoor Temperature and 100°F Water Temperature. For example with a 1.00 (OD):1.00 (SYS) ratio, if the outdoor temperature is 50°F, this means that the outdoor temperature has fallen 20° from the starting point of 70°F. Therefore, the heating water temperature will increase 20° to 120°F (100°F + 20°F).

Each building has different heat loss characteristics. A very well insulated building will not lose much heat to the outside air, and may need a Reset Ratio of 2.00 (OD):1.00 (SYS) (Outdoor : Water). This means that the outdoor temperature would have to drop 2° to increase the water temperature 1 degree. On the other hand, a poorly insulated building with insufficient radiation may need a Reset Ratio of 1.00 (OD):2.00 (SYS). This means that for each degree the outdoor temperature drops the water temperature will increase 2°. The Multi-MOD Platinum has a full range of Reset Ratios to match any buildings heat loss characteristics.

A heating curve that relies not only on Outdoor temperature but also on type of radiation will improve the comfort. See the Building Suggested Settings table for different types of radiation based on an average building insulation and heat loss. The contractor can fine-tune these settings to the specific building need.

### SPACE FEEDBACK CONCEPT

A Multi-MOD Platinum control that is equipped with Internet communication is capable of using Heat-Timer space sensors to fine-tune its outdoor reset operation while providing significant savings. The Multi-MOD Platinum adjusts the target water temperature based on the Space Feedback Gain and the difference between the current Space Average and the Space target. Example: Using a Space Feedback Gain of 4, if the Space Average is 70°F and the day target is set to 72°F, the control will add 4° to the System Target temperature for every 1° (ambient temperature) the Space Average is below the Space Target. In this example, it would add 8° to the target water temperature to compensate for the 2° reduction in the Space Average. See "Space Feedback Gain" on page 47.

If the Space temperature exceeded the Space Target by 2° while the target water temperature is at the Minimum Target temperature for an hour, the control will turn the boilers off until the Space Average drops below the Space Target.

### WARNING

When controlling a none-condensing boiler directly without the use of a mixing valve, minimum boiler water temperature must be set to boiler manufacturer specifications. In that case, system temperature must not go below such temperature.

### Suggested Reset Settings

Transfer Unit	Reset Ratio	Offset
Radiators (Steel & Cast Iron)	1.00 : 1.00	0°F
Baseboard (Finned copper tube & Cast Iron)	1.00 : 1.00	0°F
Radiant (High Mass/Concrete)	4.00 : 1.00	-10°F
Radiant (Low Mass/Joists)	2.00 : 1.00	-10°F
Fan Coils & Air Handlers	1.00 : 1.00	20°F

---

## INITIAL PILOT PROGRAM

Setting an Initial Pilot Program eases the installation and configuration of the Multi-MOD Platinum and gives the opportunity to use many of the energy saving features while providing comfort.

The program should consist of the following:

- Select the features that your system can utilize,
- Making sure you are ordering the right control and accessories (Multi-MOD Platinums do not come with sensors or stage relays, these items must be ordered separately,
- Install and wire the Control,
- Set the System Startup menu,
- Set the System Settings,
- Set the Stages and their rotation,
- Set the Schedules
- Adjust the Reset Ratio and Water Offset (In Reset Mode Only) or set the Set Point,

The following are for communication equipped controls only:

- If the control had communication, connect and install the communication,
- If the control had Internet communication, install and wire the sensors.

### MAKE SURE YOU HAVE THE RIGHT CONTROL

If you need the Multi-MOD Platinum to do additional tasks that either is not listed or do not know how to configure them, contact Heat-Timer Corp. Sales Department either by Phone (973)575-4004, E-mail to: [support@heat-timer.com](mailto:support@heat-timer.com), or using the web contact form <http://www.heat-timer.com>.

# MULTI-MOD PLATINUM FUNCTION CHART

The digital display shows the system status, set point, lead stage <in brackets>, and status of each stage.

Depress the knob to go to menu and accept changes. Rotate the knob to scroll and change settings.

Depress the button to view the date and time or to go back through the menus

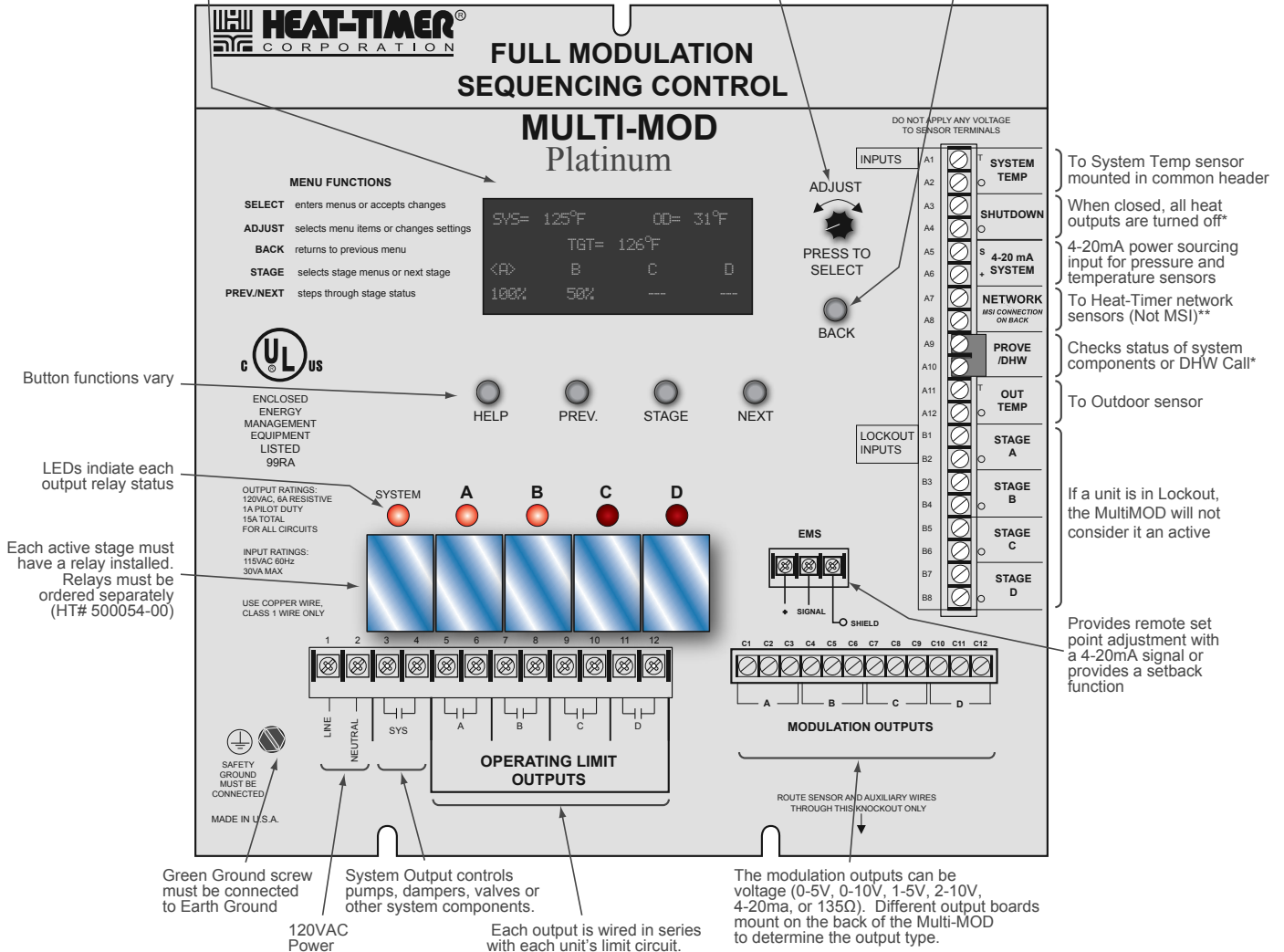

\* DRY CONTACTS ONLY

\*\* Only available with the Remote Communications package



# MULTI-MOD PLATINUM BACK CHART

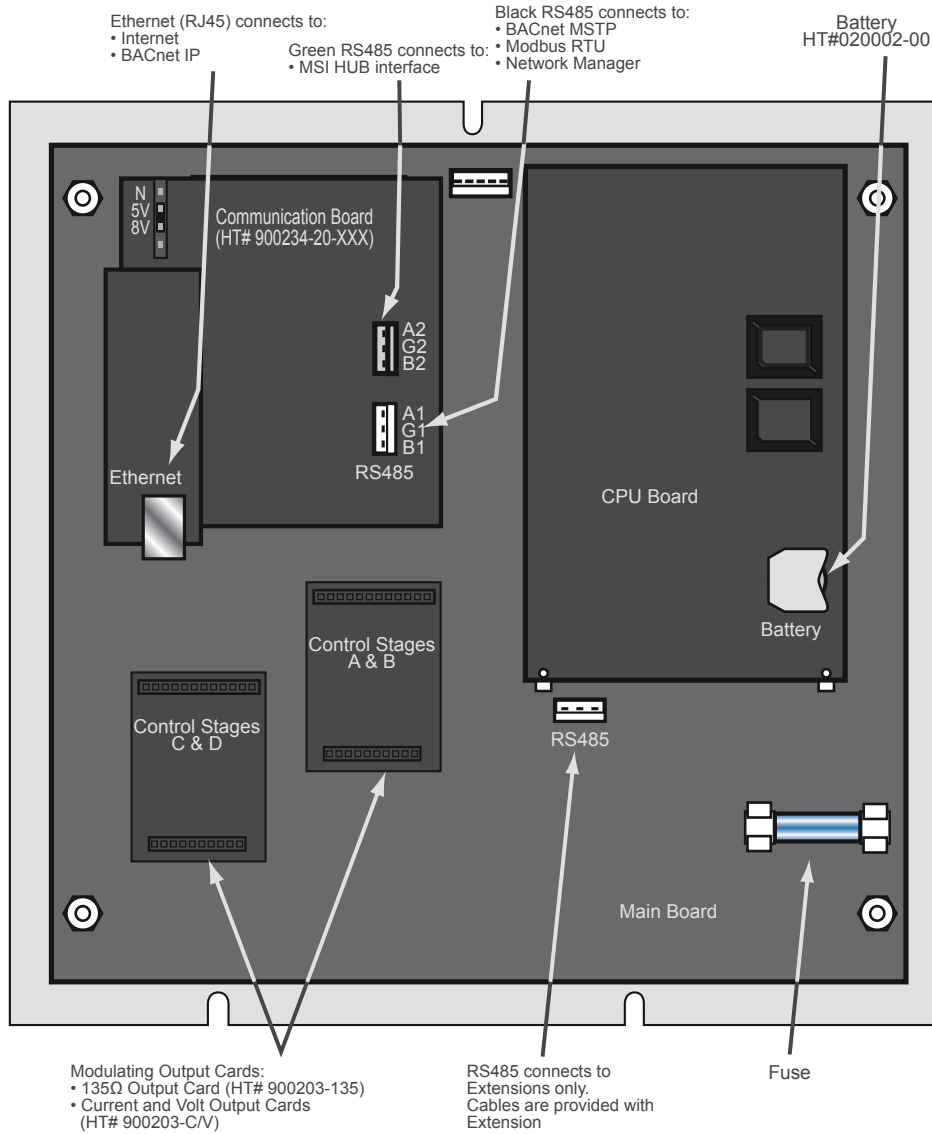

# EXTENSION FUNCTION CHART

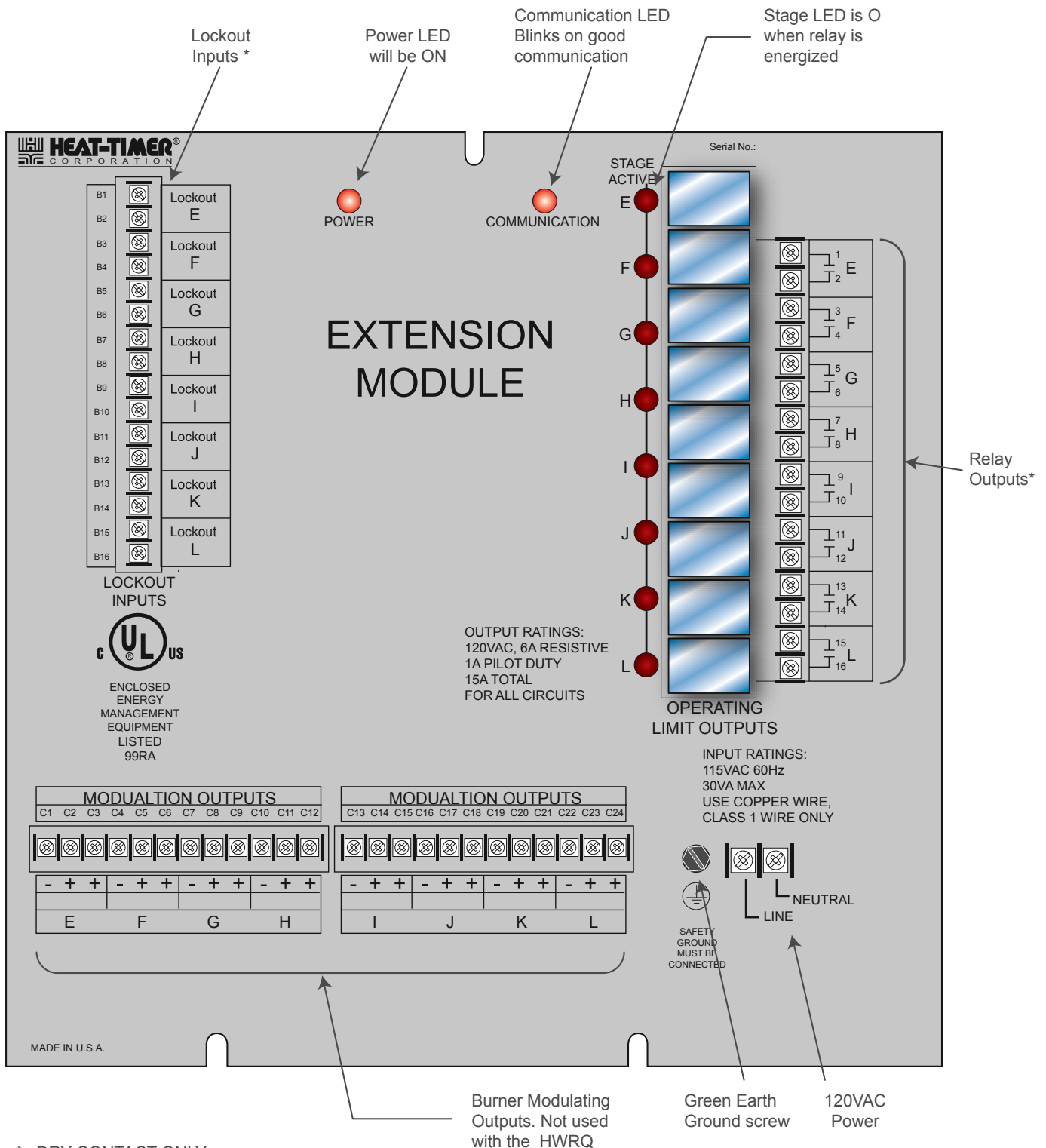

\* DRY CONTACT ONLY

HT# 059299-00 A

# EXTENSION BACK CHART

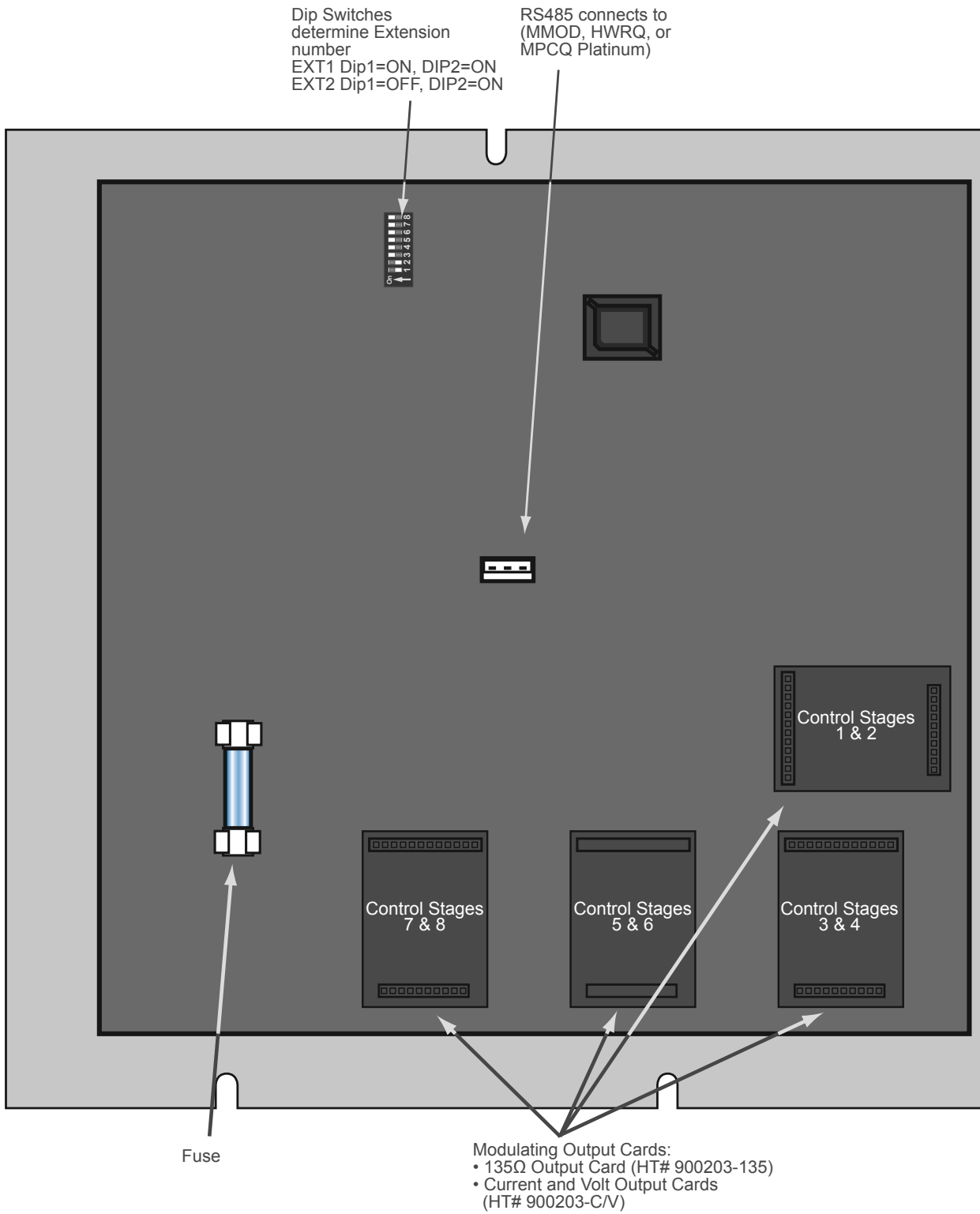

# INSTALLATION

## MOUNTING THE ENCLOSURE

- Select a location near the equipment to be controlled.
- The surface should be flat, sufficiently wide, and strong enough to hold the Multi-MOD.
- Installation location should be away from extreme heat, cold, or humidity.
- Remove the control from its enclosure by removing the top center screw and loosening the two bottom screws.
- Screw the enclosure to the surface through the mounting holes in the back of the enclosure.
- Return the panel to the enclosure. Replace the top screw and tighten the bottom two screws.

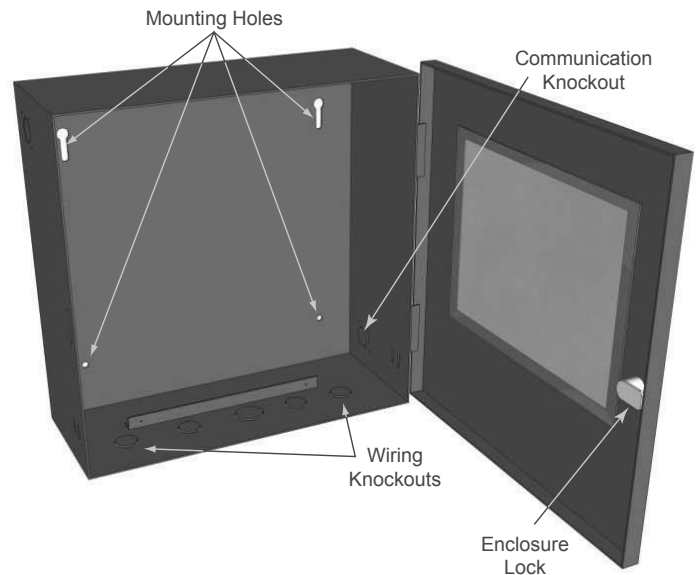

### **⚠ WARNING**

Use existing the Enclosure Knockouts.  
**DRILLING HOLES THROUGH THE CONTROL ENCLOSURE VOIDS CONTROL WARRANTY.**

## ACTIVATE THE BATTERY

- Turn the Multi-MOD Platinum panel over to reveal the piggyback circuit board (CPU board).
- Remove the plastic strap the covers the battery. The contacts should be touching the battery.

### **⚠ ALERT**

Do not install the battery unless you plan to power the control at once.  
 If the control is not powered, the battery will lose its charge in 100 days.



## REMOTE COMMUNICATION WIRING

- If a control is ordered as a standard control, it can be field upgraded to have communication by adding the appropriate upgrade kit. A new CPU board and a communication board will be included in any of the Upgrade Kits.

Communication Upgrade Kit	Part #
Multi-MOD Internet Upgrade Kit	900204-20-RINet
Multi-MOD BACnet IP or MSTP Upgrade Kit	900204-20-BAC
Multi-MOD Modbus Upgrade Kit	900204-20-BUS

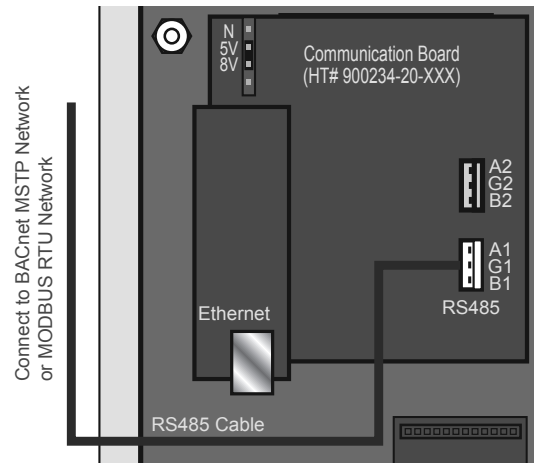

## BACNET MSTP OR MODBUS RS485 WIRING

- All Communication to Modbus RTU or BACnet MSTP must use the RS485 on the control's Communication Board.

HT# 059299-00 A

- The RS485 cable length must not exceed 3500 feet.
- The RS485 cable must use one of the Platinum control's enclosure side knockouts. Do not use bottom knockouts for communication cabling.
- Connect the RS485 cable coming from the BACnet MSTP or Modbus network to the Black RS485 communication socket on the back of the control's Communication Board. The terminals are labeled 'A1 (+)', G1 (Ground), and 'B1 (-)'.

**⚠ ALERT**  
The RS485 Ground terminal (G) **MUST** be connected to the BMS RS485 Ground.

### INTERNET OR BACNET IP ETHERNET WIRING

- The Ethernet cable must use one of the Platinum control's enclosure side knockouts. Do not use bottom knockouts for communication cabling.
- For reliable communication, the maximum Ethernet cable run must not exceed 200'.
- Use only CAT-5E Ethernet cable or better when connecting from the Internet Modem, router or the IP network to the Ethernet RJ45 communication socket on the back of the control's Communication Board.

**⚠ WARNING**  
Class 1 voltage wiring (low voltage) must use a different knockout and conduit from any Class 2 voltage wiring (high voltage).

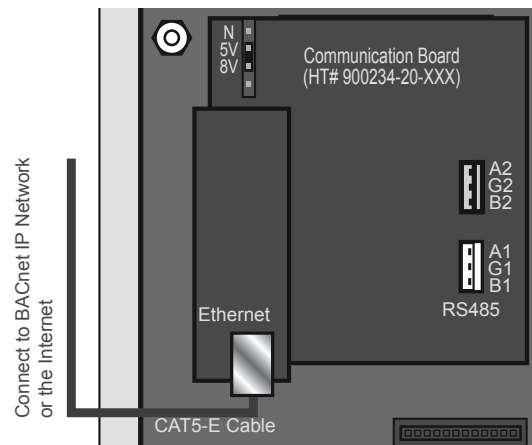

### POWER WIRING

(Terminals 1, 2, and Ground)

- Bring the 120VAC power wires through the enclosure's bottom knockouts.
- Connect the hot line to the Line terminal (1) and connect the neutral line to the Neutral terminal (2). Connect the green screw to Earth Ground.
- Heat-Timer recommends the installation of a surge suppressor and a power switch before the power line connection.

**⚠ ALERT**

- Use a separate circuit breaker for the control. Do not share the control power with other major equipment, pumps and motors.
- Output relays do not source any power. A separate power source must be used. Use the output relay to enable or disable the equipment.

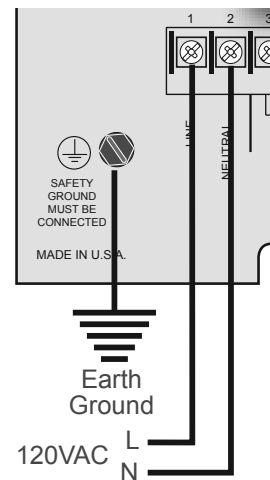

### OUTPUT RELAY WIRING

- Output relays do not source any power. If the equipment connected to an output relay requires power, an external power source must be used.
- To use an output, you must install a relay. Relays must be ordered separately (HT# 500054-00).
- Each output relay on the Multi-MOD is rated for 1 Amp (1/8 HP) at 120 VAC 60 Hz. If higher relay rating is required, connect the equipment to an external relay. Use the Multi-MOD output relay to control the external relay.

HT# 059299-00 A

## SYSTEM OUTPUT WIRING

(Terminals 3, 4)

- The System output can be used to activate a pump, a pump starter, a combustion air damper, or other equipment.
- The Multi-MOD Platinum activates the System output whenever there is a call for any of the stages. The System output remains energized whenever a stage is active.
- The System output does not source any power. A separate power source is required for the equipment.
- The System relay comes pre-installed.

### System Output Operation in Set Point Mode

- If an outdoor sensor was used, the System output will remain active after all the stages are turned off for as long as the outdoor temperature is below the outdoor Cutoff. See "Outdoor Cutoff Temperature" on page 32. If the outdoor temperature rises 2° above the outdoor Cutoff, the System output de-activates after it runs for the full Run-On period. See "System Run-On" on page 34.
- If no outdoor sensor was used and after the last stage turns off, the System output runs for the Run-On period before turning off.

### System Output Operation in Reset Mode

- The System output activated whenever the outdoor temperature drops below the outdoor Cutoff.
- When the outdoor temperature rises 2°F above the Outdoor Cutoff, the System output will remain active for the Run-On, then turn off.

## STAGE OUTPUT WIRING

Stage1 (Terminals 5, 6), Stage2 (Terminals 7, 8),  
Stage3 (Terminals 9, 10), Stage4 (Terminals 11, 12)

- The Multi-MOD Platinum is designed to operate up to four boilers without the addition of Extensions modules. The Multi-MOD Platinum can connect to a maximum of two Extension modules maximizing the number of stages controlled to 20. Each Extension module can connect to a maximum of eight stages.
- Each of the Multi-MOD Platinum or extension stages has an activation output in addition to the modulation output. Each of the stage outputs has an LED to show its status.
- Some modulating boilers may require an activation signal. The stage activation output is used to provide this signal. To use the stage activation output, you must install a relay in the stage relay socket. Relays must be ordered separately (HT# 500054-00).
- Each output relay on the Multi-MOD is rated for 1 Amp at 120 VAC 60 Hz.
- Wire the stage activation signal in series with the boiler limits.

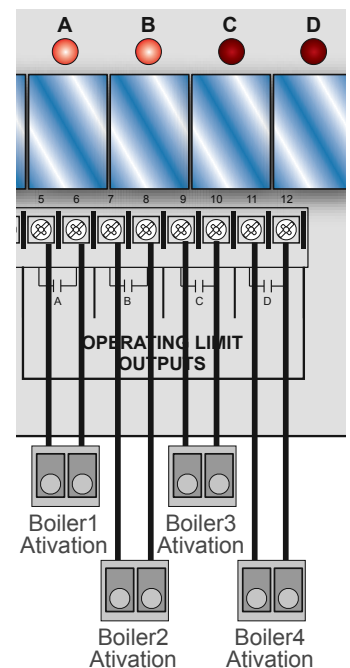
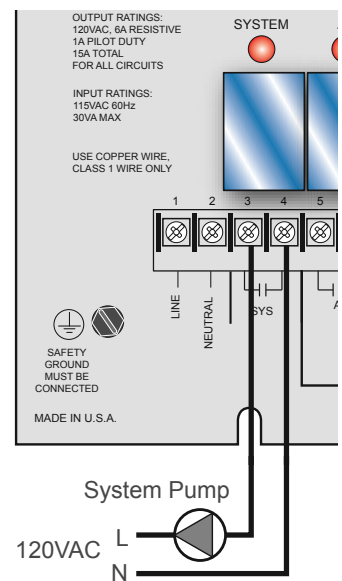

### ALERT

For proper operation set the Mode of any unused stage to Off. See "Mode" on page 39.

HT# 059299-00 A

## STAGE OUTPUT AND BOILER PUMP WIRING

- To have the Multi-MOD Platinum operate the boilers and their pumps, use SPDT relays (Single-Pole Double-Throw) and TDR relays (Time-Delay relay).
- The SPDT relay sends the activation signal from the Multi-MOD Platinum stage activation output to the boiler Interlock (TT) and its pump.
- The TDR relay receives the SPDT pump activation signal and send it to the pump. When the SPDT relay signal ends, the TDR keeps the pump running for an additional period. This additional delay acts as the Run-On delay available for the System output. See "System Run-On" on page 34.

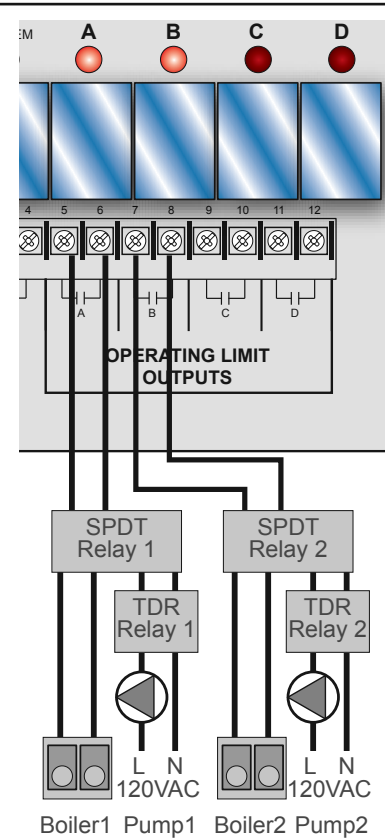

## 135Ω MODULATING MOTOR WIRING

Stage1 (Terminals C1, C2, C3), Stage2 (Terminals C4, C5, C6),  
Stage3 (Terminals C7, C8, C9), Stage4 (Terminals C10, C11, C12)

- The Multi-MOD Platinum can operate up to four 135 Ω modulating motors (Multi-MOD ordered with 135-Ohm Output cards.) Each 135 Ohm Output card operates two stages. See "Modulating Output Card Installation" on page 23.
- Terminals C1, C4, C7, and C10 on the Multi-MOD Platinum connects to the modulation decreasing terminals on the burners (Blue/Black modulating wires).
- Terminals C3, C6, C9, and C12 on the Multi-MOD Platinum connects to the modulation increasing terminals on the burners (White modulating wires).
- Terminals C2, C5, C8, and C11 on the Multi-MOD Platinum connects to the modulation common terminals on the burners (Red modulating wires).

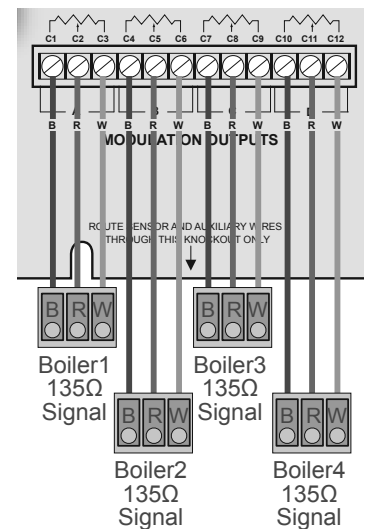

## WIRING TO 4-20 MA MODULATING MOTORS

Stage1 (Terminals C1, C2), Stage2 (Terminals C4, C5),  
Stage3 (Terminals C7, C8), Stage4 (Terminals C10, C11)

- The Multi-MOD Platinum can operate up to four 4-20 mA modulating motors (Multi-MOD ordered with C/V (Current/Voltage) output cards). See "Modulating Output Card Installation" on page 23.
- To program the control for 4-20 mA output, See "Output Type" on page 27.
- Apply the supplied label marked Current/Voltage below the modulating terminals.
- The Multi-MOD sources 24VDC excitation voltage for the 4-20mA signal.

- Terminals C2, C5, C8, and C11 on the Multi-MOD Platinum must be connected to the modulation Signal (+) terminals on the burners.
- Terminals C1, C4, C7, and C10 on the Multi-MOD Platinum must be connected to the modulation Common terminals on the burners.

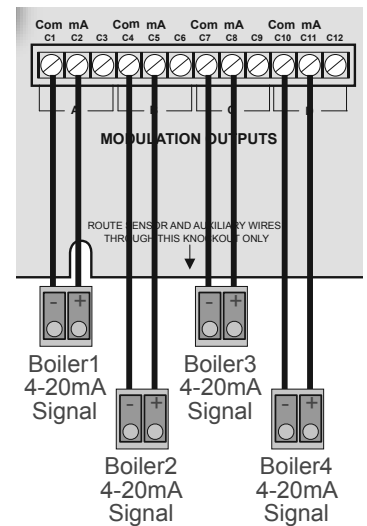

## WIRING TO VOLTAGE-MODULATING MOTORS

Stage1 (Terminals C1, C3), Stage2 (Terminals C4, C6),  
Stage3 (Terminals C7, C9), Stage4 (Terminals C10, C12)

- The Multi-MOD Platinum can operate up to four voltage-modulating motors (Multi-MOD ordered with C/V (Current Voltage) output cards). See "Modulating Output Card Installation" on page 23.
- The Multi-MOD Platinum can modulate any of the following voltage motors: 0-10V, 0-5V, 2-10BV, 1-5V. See "Output Type" on page 27.
- Apply the supplied label marked Current/Voltage below the modulating terminals.
- Terminals C1, C4, C7, and C10 on the Multi-MOD Platinum must be connected to the modulation Ground terminals on the burners.
- Terminals C3, C6, C9, and C12 on the Multi-MOD Platinum must be connected to the modulation Voltage (V+) terminals on the burners.

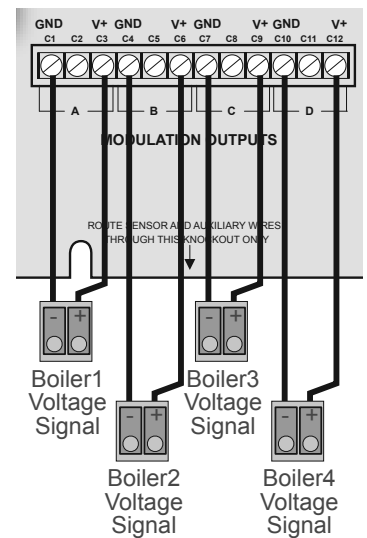

## WIRING TO MODBUS MODULATING MOTORS

(RS485 on Back of Motherboard)

- The Multi-MOD Platinum can communicate to and modulate burners equipped with the Siemens® LMV. The LMV communicates over Modbus networks. See "Stage Interface" on page 27.
- The LMV Interface communicates the boiler modulation from the Multi-MOD Platinum to the Siemens® LMV burner control. In addition, it sends the boiler lockout information from the LMV to the Multi-MOD Platinum. Each burner must be connected to a LMV Interface. The LMV Interface must be purchased separately (HT #926621-00). In addition, an Interface Power Supply (HT #926622-00) must be purchased for every 10 LMV Interfaces.
- See LMV Interface Manual for information on configuring and wiring to the Siemens® LMV equipped burners.



## INPUT WIRING

### OUTDOOR SENSOR

- An outdoor sensor must be used when selecting Reset °F or Reset °C. The sensor is used to calculate the system target. In addition it is used in the outdoor Cutoff. See "Sensor Type" on page 26 and "Outdoor Cutoff Temperature" on page 32.
- If an outdoor sensor is installed in any of the set point options, it will only be used in the outdoor Cutoff. This feature will automatically be activated when an outdoor sensor is connected.
- Use only the Outdoor Sensor included with the unit (HT# 904220-00).

#### Outdoor Sensor Installation

- Locate the sensor on the north side of the building at least 10' above the ground. The sensor MUST never be in direct sunlight.
- Be sure the location is away from doors, windows, exhaust fans, vents, or other possible heat or cool sources.
- Adhere the Outdoor Label to the back of the sensor base.
- Use the Enclosure Base bottom knockout for the conduit. Use the locknut to hold the conduit and enclosure base together. Install and screw the cover to the base.
- If screws are used to affix the enclosure to the wall, make sure to seal around the sensor and wall except from the bottom.

#### Outdoor Sensor Wiring

(Terminals A11, A12)

- Connect the sensor wires to the Out Temp terminals. Temperature sensors have no polarity.
- Connect the shield to terminal A12 with one of the other sensor wires. Do not connect the shield at the sensor end.
- The sensor wires can be extended up to 500' using 18 AWG 2-conductor shielded cable (HT# 703001-01).

### SYSTEM SENSOR

The Multi-MOD must be connected to a temperature or pressure sensor. The sensor connected must match the Sensor Type selected in the Startup menu. Sensors must be ordered separately.

#### System Temperature Wiring

(Terminals A1, A2)

- The Multi-MOD Platinum is designed to connect to a Heat-Timer temperature sensor (HT# 904250-00). The sensor must be inserted into a 3/8ID well (HT# 904011-00).
- Locate the sensor in the common header where it will register the output before any takeoffs. If the sensor cannot read the output of all the stages, it will not be able to control the system properly.

**⚠ WARNING**  
Class 1 voltage wiring (low voltage) must use a different knockout and conduit from any Class 2 voltage wiring (high voltage).

**⚠ WARNING**  
To avoid damage to the Multi-MOD, NO VOLTAGE can be applied to the Multi-MOD Platinum input terminals.

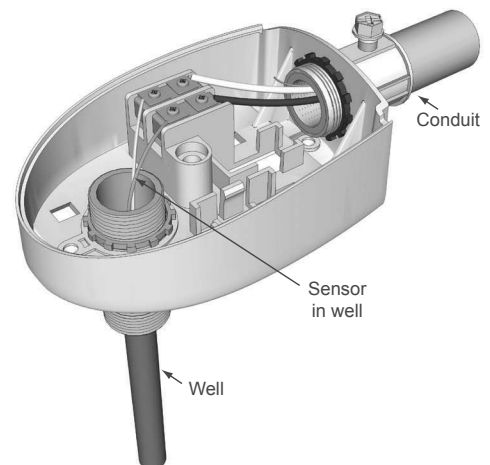
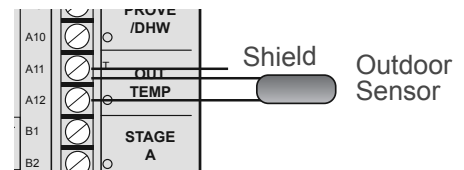
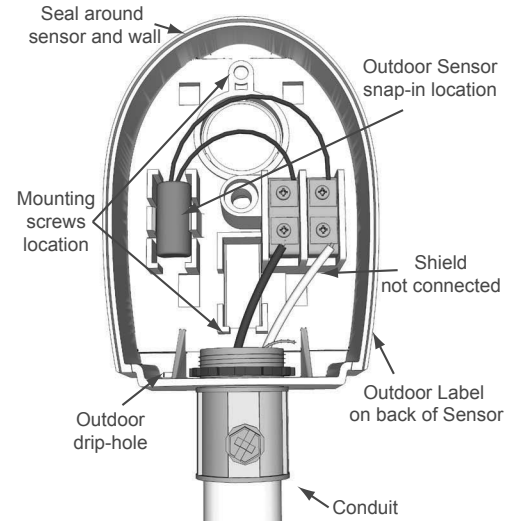

- Attach the sensor wires to the Out Temp terminals (A11 and A12). Temperature sensors have no polarity.
- Connect the shield to terminal A12 with one of the other sensor wires. Do not connect the shield at the sensor end.
- The sensor wires can be extended up to 500' using shielded 2-conductor cable (#18/2).

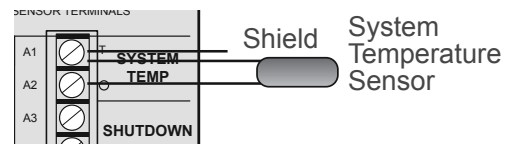

#### 4-20MA TEMPERATURE SENSOR WIRING

(Terminals A5, A6)

- The Multi-MOD Platinum can connect to a 4-20mA temperature sensor (HT# 904160-00). See "Sensor Type" on page 26.
- Locate the temperature sensor on the main supply header where it will register the output of all the stages. If the sensor cannot read the output of all the stages, the Multi-MOD Platinum will not be able to control the stages properly.
- 4-20mA Temperature Sensor wires can be extended up to 500' by splicing with 18 gauge twisted pair wire.
- Connect the sensor's Blue wire to terminal PRESS - A5 (S).
- Connect the sensor's Brown wire to terminal PRESS - A6 (+).
- Cut the rest of the transducer wires and tubes.

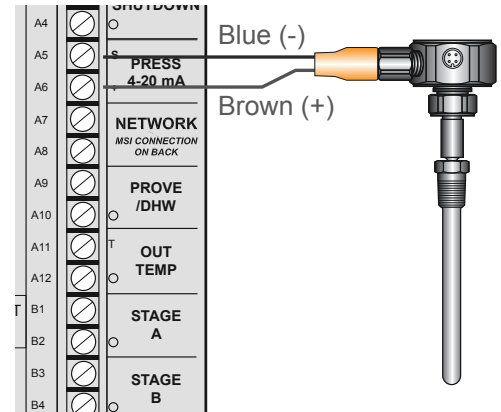

#### System Pressure Transducer Wiring

(Terminals A5, A6)

- The Multi-MOD Platinum is designed to connect to a pressure transducer. See "Sensor Type" on page 26.
- Locate the transducer on the main supply header where it will register the output of all the stages. If the transducer cannot read the output of all the stages, the Multi-MOD Platinum will not be able to control the stages properly.
- Attach the transducer to the steam header using a 1/4" isolation tube (pigtail) (HT# 135020-00).
- Pressure transducer wires can be extended up to 500' by splicing with 18 gauge twisted pair wire.
- Connect the Black wire from the pressure transducer to terminal PRESS - A5 (S).
- Connect the Red wire from the pressure transducer to terminal PRESS - A6 (+).
- Cut the rest of the transducer wires and tubes.

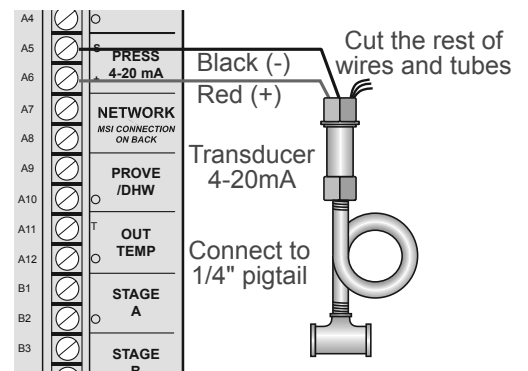

#### SHUTDOWN WIRING

(Terminals A3, A4) Dry-Contact

- The Shutdown is used to turn off the control remotely. It can be configured for Normally Open (Shutdown) or Normally Closed (TSTAT)
- If boilers are running and the shutdown terminal is closed remotely all active stages will modulate down to low fire (Ignition %). They will remain there until the adjustable Soft-Off period has finished. See page 37 for Soft-Off.
- The System output will remain active until the Run-On Delay ends, then it will also turn off. See "System Run-On" on page 34.

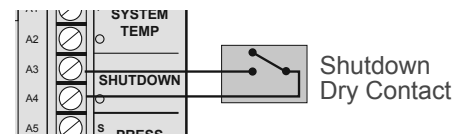

**WARNING**

To avoid damage to the Multi-MOD, NO VOLTAGE can be applied to the Multi-MOD Platinum input terminals.

## PROVE WIRING

(Terminals A3, A4) Dry-Contact

- The System Prove feature is provided to check the system component operation status before activating any stages. Prove must be selected from the Prove/DHW Startup option. See "Prove/DHW Mode" on page 28.
- A typical use of this feature is to check for water flow before firing any boiler stages. When there is a call for heat, the System Output relay activates the system pump. When the pump establishes flow, a flow switch closes the Prove input terminals. Only then, can the Multi-MOD Platinum activate and modulate the boilers as required to hold the set point.
- If the Prove input is open on a call for a stage, the Multi-MOD Platinum will enable only the System output. All stage outputs will be off when the Prove input is open.
- A factory installed jumper provides the System Prove signal. Do not remove the jumper unless it is replaced by a Prove signal.

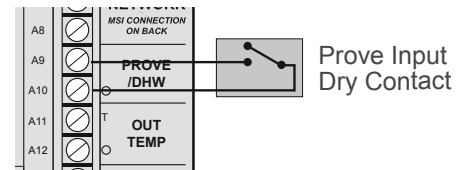

**WARNING**

Do not remove the factory installed Prove jumper unless it is replaced by a prove signal. If the Prove input is not closed/shorted, the Multi-MOD Platinum will NOT activate the stages. The Prove input cannot be used as a safety limit. All equipment must have its own certified limit and safety controls as required by code.

## DHW CALL WIRING

(Terminals A3, A4) Dry-Contact

- The DHW Call feature is used to raise the system Target to the DHW Set Point. In addition, it regulates the operation of the System output. The System output operation varies based on the DHW Priority setting selected from the Startup menu. See "Prove/DHW Mode" on page 28.
- Wire a DHW aquastat to the DHW Call terminals. The call must be dry-contact.
- Remove the jumper on the DHW terminals for proper operation.

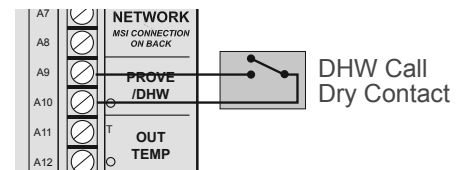

## LOCKOUT INPUTS WIRING

(Terminals B1 through B8) Dry-Contact

- The Multi-MOD Platinum will not activate or modulate any Stage in Lockout. A Lockout signal tells the Multi-MOD Platinum that the related stage is encountering a problem and cannot be started. The Stage display status will show (L/O).
- However, using the Lockout will drastically improve the control's set point management.
- There is a Lockout input for each stage on the Multi-MOD Platinum and Extension Module.
- The Lockout signal must be a dry-contact closure from the boiler. No voltage can be placed across the terminals. If the source of the signal has voltage, use a relay.

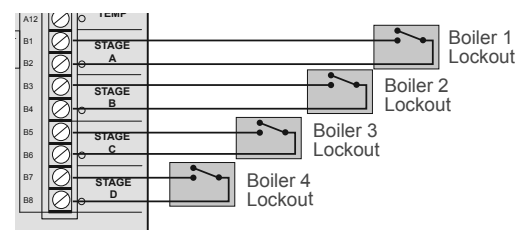

**WARNING**

Do not use the Lockout inputs as a safety check. All equipment must have their certified limit and safety controls installed as required by code.

## SETBACK WIRING

(EMS Input Terminals +, Signal) Dry-Contact

- The Setback is used to reduce the system target when less load is required during the night or on the weekends when a building is unoccupied, but a minimum level of heat is still required.
- To use the Setback, the EMS Input mode must be set to Setback. See "EMS Input Mode" on page 27. Also, the Setback value must be greater than 0. See "Setback" on page 35.
- The Setback can be activated based on the Night Schedule settings or an external dry-contact Setback input.
- When using an external Setback, wire the dry-contact Setback signal to the EMS terminals (+) and (SIGNAL).
- When the Setback terminals are shorted, the Setback is enabled and the Multi-MOD Platinum will hold the lower Set Point. The main display will show "Setback to: 150F" to indicate this condition.
- When the setback signal ends, the Multi-MOD Platinum will revert to the higher target setting.

**⚠ WARNING**

To avoid damage to the Multi-MOD, NO VOLTAGE can be applied to the Multi-MOD Platinum input terminals.

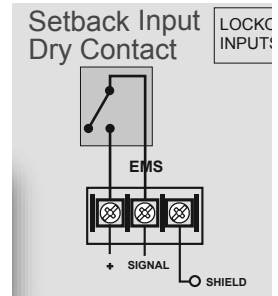

## INTERFACING TO MPC

(Terminals A3, A4) Dry-Contact

- The MPC Platinum is a steam cycling outdoor reset control.
- The MPC Platinum can be used to activate and deactivate the Multi-MOD Platinum Shutdown terminals. First, the MPC Platinum Option 2 Relay Mode must be set to Inverse of Output. See MPC Platinum Manual.
- Wire the MPC Platinum Option 2 output terminals 15 and 16 to the Multi-MOD Platinum Shutdown input terminals A3 and A4.

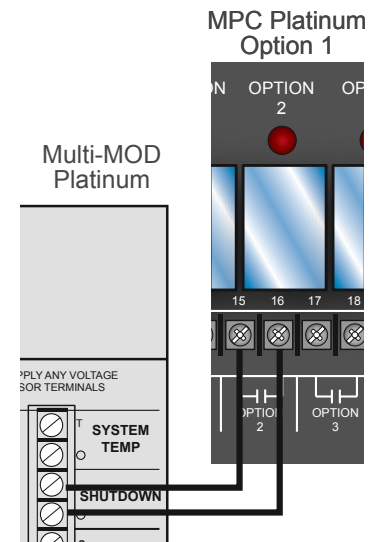

## INTERFACING TO HWR

(Terminals A1, A5, and A6)

- The HWR Platinum is a hydronic outdoor reset control.
- The HWR Platinum is capable of controlling the Multi-MOD Platinum. To set the Multi-MOD Platinum to operate with the HWR, set the Multi-MOD Platinum Sensor Type to HWR. See "Sensor Type" on page 26.
- In the HWR mode, the Multi-MOD Platinum does not require any sensor. The HWR Platinum will have system and outdoor sensors. The HWR Platinum increases or decreases the Multi-MOD Platinum modulation.
- Connect the HWR terminal 11 to the Multi-MOD terminal A6.
- Connect the HWR terminal 12 to the Multi-MOD terminal A5.
- Connect the HWR terminal 13 to the Multi-MOD terminal A1.

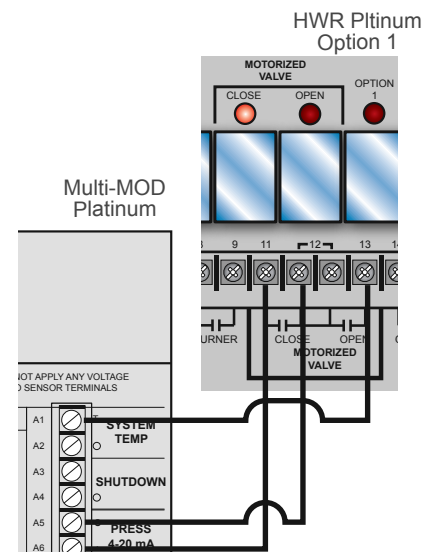

HT# 059299-00 A

# CONNECTING MULTI-MOD PLATINUM TO EXTENSIONS

(RS485 on Back of Motherboard)

- When an application requires more than 4 modulating stages, up to two Extension Modules can be used to add 16 additional stages. Each extension can connect to 8 stages with lockout inputs. The Multi-MOD Platinum can manage the Extension panels using an RS485 connection.
- Each extension is supplied with all the necessary cables to connect to the Multi-MOD Platinum and the other extension. The Round-to-Round cable connects one enclosure to the other (HT# 900065-00).
- The Flat-to-Round cable connects the main PCB board to the enclosure (HT# 900048-00).
- A set of dip switches on the back of the Extension Module is used to configure the Extensions ID. See Dip Switch settings on the right.
- The connection from the Multi-MOD to the Extensions can be either in parallel or in series. See diagrams

Extension 1  
Dip Switch Setting

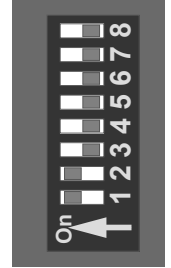

Extension 2  
Dip Switch Setting

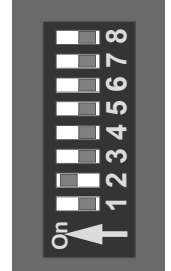

## ⚠ WARNING

To connect to the Extension, use the RS485 connector on the Multi-MOD's main PCB board. DO NOT use the RS485 connector on the BACnet communication board

- Note that, Extension panels do not come with Modulating Output Cards or relays. These items must be purchased separately.

### Connecting two Extension Panels in Series

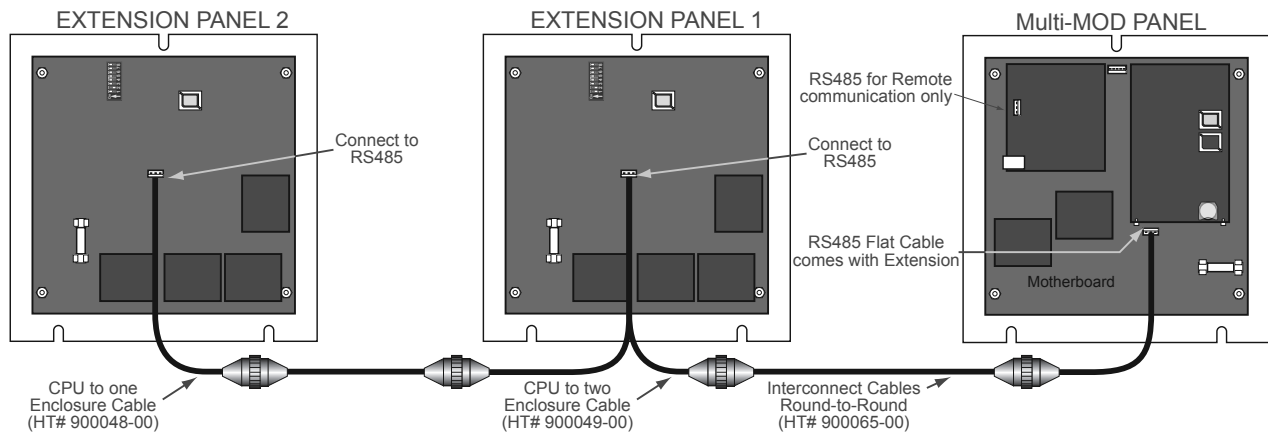

### Connecting two Extension Panels in Parallel

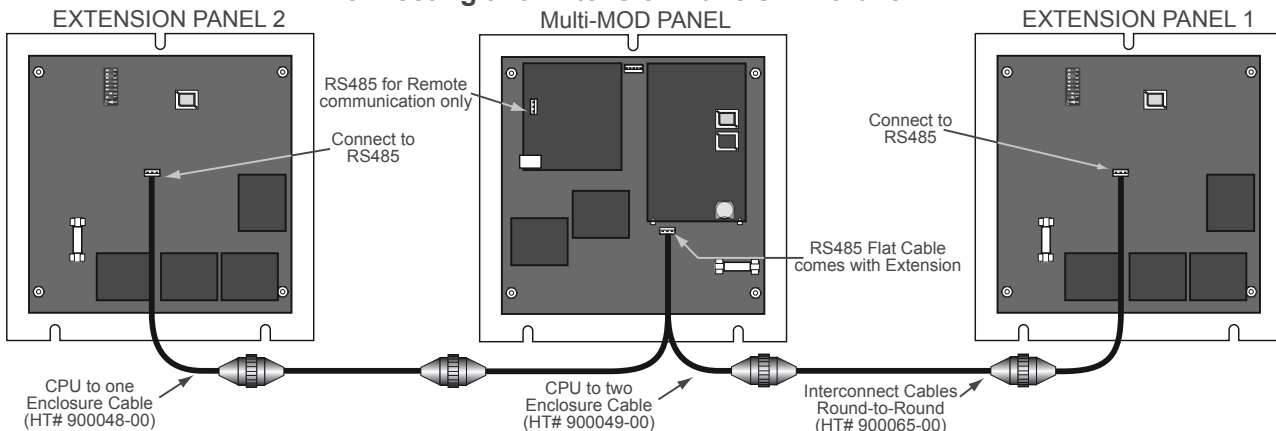

HT# 059299-00 A

## EXTERNAL SET POINT WIRING

(EMS Input Terminals +, Signal, Shield)

- The Multi-MOD Platinum can be configured to accept a remote 4-20mA set point from an Energy Management System (EMS).
- Set the Multi-MOD Platinum EMS Input Mode to EMS-Control. See "EMS Input Mode" on page 27.
- There are two ways to wire the 4-20mA signal. The method used depends on signal power source.
- If the EMS sources the voltage for the 4-20mA signal, connect the EMS signal (+) to the Multi-MOD EMS SIGNAL terminal. Then connect the EMS signal (-) to the Multi-MOD EMS SHIELD terminal. This is the most common method.
- If the Multi-MOD Platinum sources the current for the 4-20mA signal, connect the EMS signal (+) to the Multi-MOD EMS + terminal. Then connect the EMS signal (-) to the Multi-MOD EMS SIGNAL terminal.

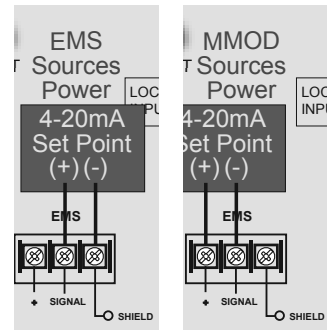

## CONNECTING INTERNET COMMUNICATION

- Internet capable Multi-MOD Platinum controls are equipped with an Internet communication board installed on the back of the main board.
- Connect the Ethernet cable coming from the Internet Modem or Internet server to the RJ45 socket on the back of the communication board.
- See Platinum Internet Setup Manual for additional information on configuring Internet controls and their features.

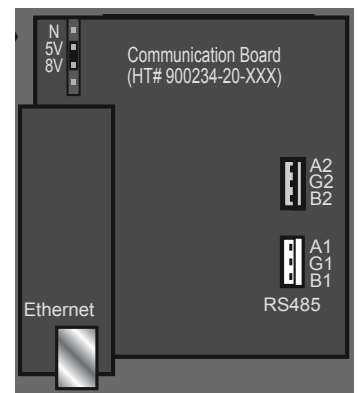

## CONNECTING BACNET COMMUNICATION

- BACnet capable Multi-MOD Platinum controls has a BACnet communication board that can communicate over BACnet IP or BACnet MSTP networks.
- When using BACnet IP, connect the BACnet CAT5 Ethernet cable coming from the BACnet network to the BACnet RJ45 Communication socket (Ethernet socket) on the Multi-MOD communication board.
- When using BACnet MSTP, connect the RS485 BACnet cable coming from the BACnet network to the Black RS485 Communication socket on the Multi-MOD communication board.
- Set the Multi-MOD BACnet Settings as described in the BACnet Manual.

## CONNECTING MODBUS COMMUNICATION

- MODBUS capable Multi-MOD Platinum controls has a MODBUS communication board that can communicate over MODBUS RTU networks.
- Connect the RS485 BACnet cable coming from the MODBUS network to the Black RS485 Communication socket on the Multi-MOD communication board.
- Set the Multi-MOD MODBUS Settings as described in the MODBUS Manual.

## NETWORK SENSORS WIRING

- The Multi-MOD Platinum with Internet communication is capable of connecting to large number of Network sensor. Heat-Timer has a variety of Network Sensors that can measure temperature, pressure, vacuum, humidity, oil level, and other mediums. See Internet Communication Manual for information on connecting and configuring network sensors.

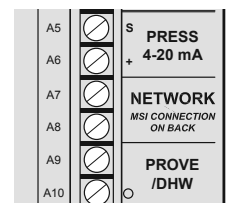

HT# 059299-00 A

## MODULATING OUTPUT CARD INSTALLATION

- The Multi-MOD Platinum is equipped with two Modulating Output Cards. While the extension can accept up to four output cards. Every two modulating boiler outputs are controlled by one Modulating Output Card. See "Multi-MOD Platinum Back Chart" on page 9 and "Extension Function Chart" on page 10.
- The cards are installed on the back of the control's main board.
- There are two types of cards available:
  - 135Ω Cards (HT# 900203-135): operates two 135 Ohm modulating motors.
  - Current/Voltage Cards (HT# 900201-C/V): operates two 4-20mA, 0-10V, 0-5V, 2-10V, or 1-5V modulating motors. Each card can provide only one output signal. Affix the Current Voltage label below the Modulation Output terminals (C1 through C12).
- The Multi-MOD Platinum comes with its Modulating Output cards installed. However, when ordering Extension Modules, the Modulating Output Cards must be ordered separately.

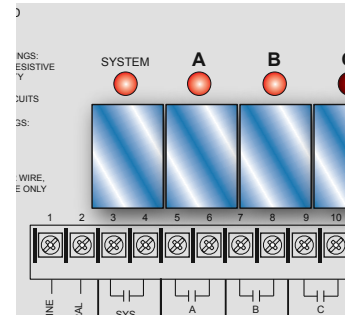

## DISPLAY

- The Multi-MOD Platinum is equipped with an 80 character (4 lines x 20 character) bright digital display.
- All the menus are in English.
- The default main display is divided into four rows.
  - First Row: displays System and Outdoor sensor values.
  - Second Row: displays important messages.
  - Third Row: displays stage letters. It also displays the lead stage in brackets.
  - Fourth Row: displays stage firing or lockout status.



## BUTTON FUNCTIONS

- |                                 |   |
|---------------------------------|---|
| <b>Press To Select (Adjust)</b> | When in the menus, rotate the knob to scroll through the menus.   |
| <b>Back</b>                     | When in a setting, scroll to change the setting.<br>Press the knob to enter the selected menu or to accept the current settings value.  |
| <b>Next</b>                     | In the default screen, pressing it shows the date, time, and space average.<br>Is used to go to the previous menu.  |
| <b>Stage</b>                    | In Boiler menu, goes to the next setting.<br>In Schedules, goes to next schedule time on schedules,<br>From the default screen, pressing it enters the Stage menu.<br>In the Stage menu, switches between stages. |
| <b>Prev.</b>                    | In Schedules, switches between different weekdays,<br>In Schedules, clears a specific schedule setting.<br>In Stage menu, goes to previous boiler settings.   |
| <b>Help</b>                     | When clicked in a specific menu item provides help instructions.  |

HT# 059299-00 A

## DISPLAY STAGE MODULATION STATUS

- --- Stage Mode is set to Off due to no call for heat/cool.
- 97% Stage Mode is set to Auto. The Multi-MOD modulate the stage to the indicated percentage.
- ON Stage Mode is set to ON. The stage firing is at 100% (stage in bypass). See "Mode" on page 39.
- OFF Stage Mode is set to OFF. The stage is unavailable or does not exist.
- m95% Stage Mode is set to Manual. Manual modulation is set to 95%.
- C/E The Extension Module stage is NOT communicating back to the Multi-MOD.
- L/O The stage Lockout input terminals are shorted. See "Lockout Inputs Wiring" on page 19.

### DISPLAY MESSAGES

The Multi-MOD Platinum normal display layout uses the second row from the top for operating messages. The following is a list of the most common Message Display Line information:

Ack Received	The Internet control has acquired connection to the Heat-Timer communication server. This message is displayed for 2 seconds after one minute of power up.
BST: 170°F	Boost is active. The new target temperature is 170°F. See "Boost and Early Shutdown" on page 34.
DHW Call (180°F)	A DHW Call is active. The DHW Set Point is 180°F. See "DHW Set Point" on page 29.
Fast Cool Down	ESD (Early Shutdown) is active. The new target is equal to the Fast Cool Down setting. See "Fast Cool Down" on page 30.
Holding Until 150°F	The lead stage is in Last-Stage-Hold. This example shows that the lead stage will turn off when system temperature reaches 150°F. See "Last-Stage-Hold" on page 37.
Internet Control	The control is an Internet control and the display is in Screen Saver Mode. See "Internet Communication" on page 45.
Lag Delay: 123	The lead stage is at 100% and the remaining purge time to start the lag boiler in seconds is 123. See "Lag Delay" on page 37.
Network Panel	The control has a communication package installed and the display is in Screen Saver Mode.
Prove Failure	After boilers have run for a while, Prove signal was opened. All boiler outputs are de-activated. However, the System relay will remain energized. See "Prove Wiring" on page 19.
Purge Delay: 23	The current boiler is in purge and the remaining purge time in seconds is 23. See "Purge Delay" on page 36.
Shutdown Active	The Shutdown input is shorted/active. No stages will be active. See "Shutdown Wiring" on page 18.
Shutdown by EMS	The EMS set point signal is below 2mA or above 22mA. See "EMS Input Mode" on page 27.
System Run-On: 46	The System output is ON for the System Run-On Delay. The remaining run-on is 46 seconds before turning off. See "System Run-On" on page 34.
Waiting for Prove	The System output is ON and the prove Input is open. No stage output is active. See "Prove Wiring" on page 19.



# SYSTEM STARTUP MENU

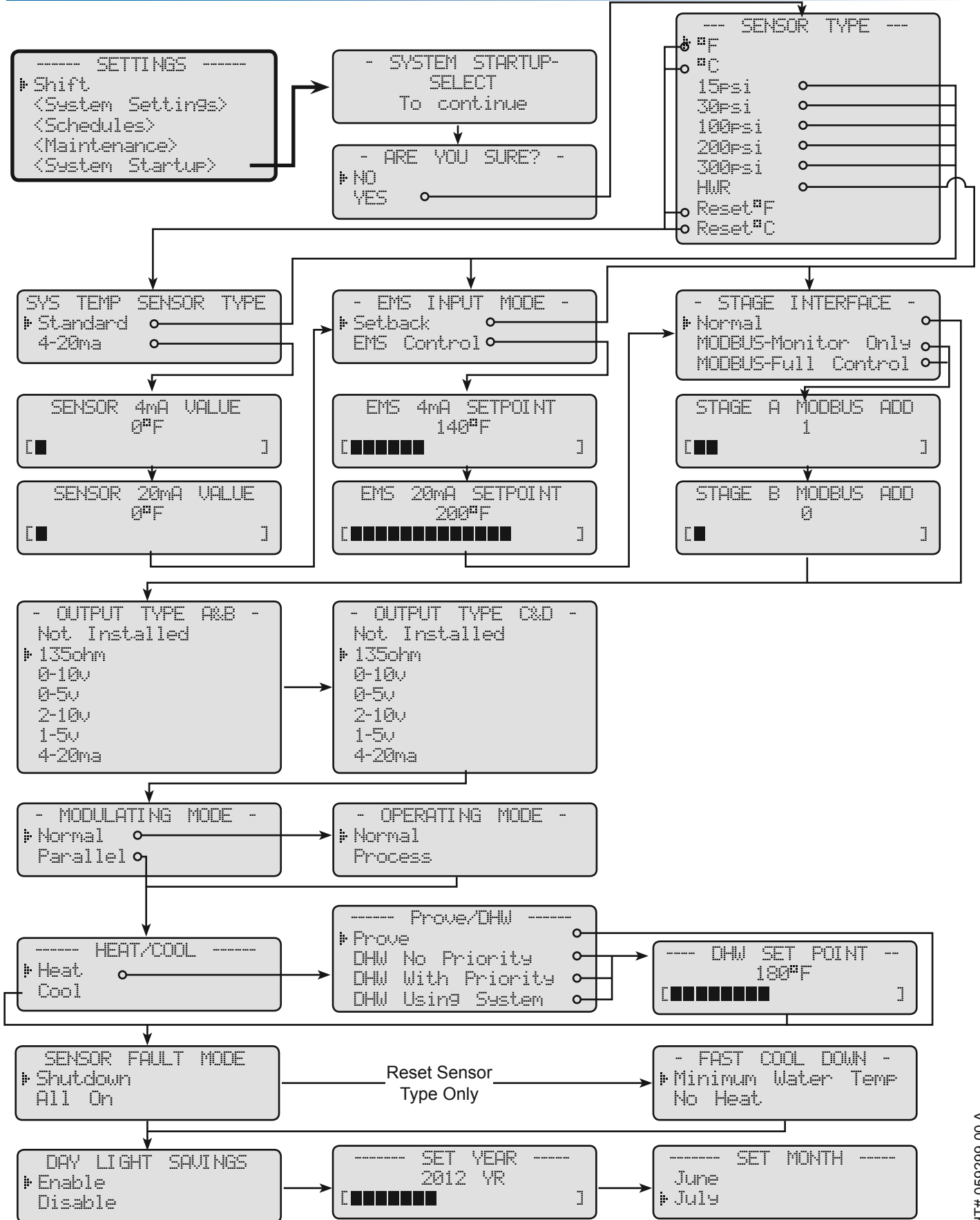

HT# 059299-00 A

# SYSTEM STARTUP

PRESS TO SELECT: /<System Startup>

- The Startup menu settings are used to match the control logic to the application. These settings must be set by a qualified installer.
- Several warnings are displayed when entering the Startup menu.
- On the first control power up, the System Startup menu screens will appear after the control initialization is complete. If it doesn't, the Multi-MOD Platinum has already been configured. To check the configuration or to make changes, follow the System Startup menu steps.

**⚠ WARNING**  
The Startup settings must be set by a qualified installer.

## SENSOR TYPE

Temperature Options: Set Point: (°F, °C), HWR, Reset: (°F, °C),  
 Pressure Options: (15psi, 30psi, 100psi, 200psi, 300psi), Default: Set Point °F  
 PRESS TO SELECT: /<System Startup>/ Sensor Type

- The °F, °C, 15 PSI, 30 PSI, 100 PSI, 200 PSI, and 300 PSI are set point options. That means, the control will modulate the stages to maintain a fixed set point. See "Set Point" on page 32.
- All Set point modes do not require an outdoor sensor. If an outdoor sensor is connected in any of the Set Point modes it will be used only as an outdoor cutoff.
- The Reset °F and Reset °C are designed to change the set point based on the outdoor temperature and other reset parameters. See "Reset Ratio" on page 33.
- Reset modes require the use of an outdoor sensor.
- If the HWR Platinum is used to control the Multi-MOD Platinum, select the HWR option. No system sensor is required in this case. See "Interfacing to HWR" on page 20.

```

--- SENSOR TYPE ---
# °F
# °C
15psi
30psi
100psi
200psi
300psi
HWR
Reset°F
Reset°C
    
```

**⚠ ALERT**  
The Multi-MOD Platinum measures the System Sensor input based on the Sensor Type selected. See "Sensor Type Table" below.

## SENSOR TYPE TABLE

SENSOR TYPE	SET POINT		SETBACK	LAST STAGE HOLD		GAIN / THROTTLE (PROCESS)*		SYSTEM SENSOR TERMINALS
	Range	Default	Range	Range	Default	Range	Default	
°F	-40°F to 250°F	70°F	1°F to 80°F	0F° to 30F°	0F°	-10 to +10 1 to 20*	2	A1, A2
°C	-40°C to 121°C	70°C	1C° to 44C°	0C° to 17C°	0C°	-10 to +10 1 to 11*	1	
15 PSI	0.0 to 15.0 PSI	10.0 PSI	0.0 to 7.5 PSI	0.0 to 3.0 PSI	0.0 PSI	-10 to +10 0.25 to 20.0*	1.0	A5, A6
30 PSI	0.0 to 30.0 PSI	10.0 PSI	0.0 to 7.5 PSI	0.0 to 3.0 PSI	0.0 PSI			
100 PSI	0 to 100 PSI	30 PSI	0 to 75 PSI	0 to 10 PSI	0 PSI			
200 PSI	0 to 200 PSI	60 PSI	0 to 150 PSI	0 to 20 PSI	0 PSI			
300 PSI	0 to 300 PSI	80 PSI	0 to 200 PSI	0 to 30 PSI	0 PSI			

♦ Available in Process Operating Mode only. See "Operating Mode" on page 28.

## SYSTEM TEMPERATURE SENSOR TYPE

(Available when Sensor Type = °F, °C, Reset °F, Reset °C)  
 Standard, 4-20mA Default: Standard  
 PRESS TO SELECT: /<System Startup>/ Sensor Type/ System Temp Sensor Type

```

SYS TEMP SENSOR TYPE
# Standard
4-20ma
    
```

- The Standard option uses Gold Series thermistor-type temperature sensors. These sensor can measure temperatures up to 250°F / 121°C. See "System Sensor" on page 17.

HT# 059299-00 A

- The 4-20ma option is used with the 4-20mA temperature sensor (HT# 904160-00). These sensors can be configured to read temperatures up to 480°F / 268°C. The user must set the 4ma and 20ma temperature range to match the sensor configuration. These sensors' ranges must be set by Heat-Timer. See "4-20mA Temperature Sensor Wiring" on page 18.
- Values that are higher than 21.6mA shall read SHORT. Values that are lower than 2.4mA shall read OPEN.

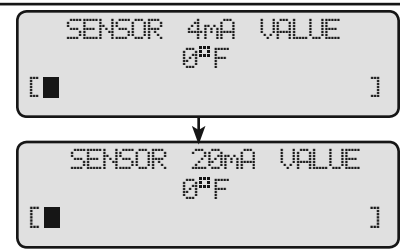

## EMS INPUT MODE

(Available In Sensor Type = °F, °C, and any of the PSI options)

Setback, EMS Control

Default: Setback

4mA Adjustable from 70°F/21°C to 200°F/93°C

Default: 140°F/ 60°C

20mA Adjustable from 90°F/32°C to 240°F/116°C

Default: 200°F/ 93°C

PRESS TO SELECT: /<System Startup>/.../Sensor Type/EMS Input Mode/ EMS 4mA SP/..

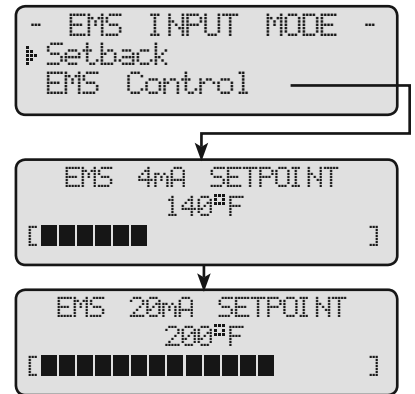

- Setback allows the Set Point to be adjusted manually.
- EMS Control allows the set point to be sent remotely using 4-20mA signal. The set point range must be set to match the EMS signal's set point range using the 4mA and the 20mA temperature settings. See "External Set Point Wiring" on page 22.
- An active signal must be between 2 and 22mA. Any signal out of this range shuts down the system and displays "Shutdown by EMS".

## STAGE INTERFACE

Normal, MODBUS-Monitor Only, MODBUS-Full Control

Default: Normal

Stage Modbus from 0 to 247

Default: 0

PRESS TO SELECT: /<System Startup>/.../Stage Interface/ Stage A Modbus Add/ ...

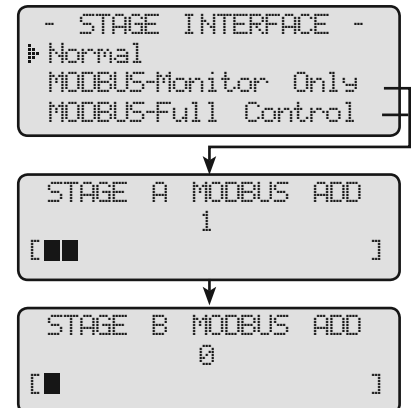

- These options are designed for Modbus operating burners equipped with the Siemens LMV controller. If the burner did not have Modbus communication, then select Normal.
- The MODBUS-Monitor Only option receives the alarm lockout status through the Siemens LMV Interface.
- The MODBUS-Full Control option sends the modulation percent and receives the lockout status through the Siemens LMV Interface.
- Order the LMV Interface for each of the MODBUS burners (HT# 926621-00). In addition, order the Interface Power Supply (HT #926622-00) for every 10 burners. See LMV-Interface Manual.
- When any of the Modbus options is selected from the Stage Interface menu, the Stage Modbus Address will follow.
- Each Stage address must be unique on the Modbus network.
- To exit the Stage Modbus Address, enter an address of 0 for the stage following the last stage.

**⚠ ALERT**

Regardless of the Modbus options selected, the Multi-MOD Platinum will also send a modulation signal to every active boiler through the Modulation Output terminals.

## OUTPUT TYPE

135Ω, 0-10V, 0-5V, 2-10V, 1-5V, 4-20mA

Default: 0-10V, 135Ω

PRESS TO SELECT: /<System Startup>/ Sensor Type/.../Output Type A&B

- The Multi-MOD Platinum has two Modulating Output Cards. Each card modulates two stages. Both stages must use the same modulating signal. See "Modulating Output Card Installation" on page 23.
- Output Cards can be either 135Ω Cards for 135 ohm modulating motors or Current/Voltage Cards for current or voltage signal operating motors.



- The cards come pre-installed on the back of the Multi-MOD's main board. Extension Modules do not come with Modulating Output Cards. The cards must be purchase separately.
- Select the current or voltage output cards output signal to match the burner modulation signal.

**⚠ WARNING**  
The modulating burner signal must match the output card and Output Type setting.

## MODULATING MODE

Normal, Parallel

Default: Normal

PRESS TO SELECT: /<System Startup>/ Sensor Type/.../Output Type A&B/ Modulating Mode

```
-MODULATING MODE -
# Normal
Parallel
```

- Condensing boilers maximize their efficiency at lower modulation. It is preferred to run these boilers using the Parallel mode.
- The Parallel option runs multiple boilers at lower firing rate instead of a single boiler at higher firing rate.
- The Normal modulation is designed to operate non-condensing boilers. These are normally burners with high turndown ratios.

## OPERATING MODE

(Available with Normal Modulating Mode Only)

Normal, Process

Default: Normal

PRESS TO SELECT: /<System Startup>/ Sensor Type/.../ Modulating Mode/ Operating Mode

```
-OPERATING MODE -
# Normal
Process
```

- Normal Operating Mode uses PID logic to modulate the stages. It is designed for slow responding applications as in building heating.
- Select Process when the system is required to keep a tight set point control while experiencing sudden big changes in the load as in some processing applications. Note that big load changes may cause stages to short cycle.
- To adjust the system response, use the Gain. See "Gain" on page 36.

## HEAT/COOL MODE

Heat, Cool

Default: Heat

PRESS TO SELECT: /<System Startup>/ Sensor Type/.../ Operating Mode/ Heat-Cool Mode

```
--- HEAT/COOL ---
# Heat
Cool
```

- The Multi-MOD Platinum can operate in heating or in cooling applications. In Heating, the Multi-MOD Platinum will modulate stages when the system is below the set point. In addition, the system relay will energize when the outdoor temperature is at or below the Outdoor Cutoff setting.
- In Cooling, the Multi-MOD Platinum will modulate stages when the system is above the set point. In addition, the system relay will energize when the outdoor temperature is at or above the Outdoor Cutoff setting.

## PROVE/DHW MODE

Prove, DHW No Priority, DHW with Priority

Default: Prove

PRESS TO SELECT: /<System Startup>/ Sensor Type/.../ Heat-Cool Mode/Prove-DHW

```
----- Prove/DHW -----
# Prove
DHW No Priority
DHW With Priority
DHW Using System
```

- The Prove option is used to check on system components before starting any stage. One of its common uses is to connect the Prove input to a flow switch to prevent boilers from firing during no flow. The Multi-MOD Platinum will not start any boiler stage unless the Prove/DHW input (terminals A9 and A10) are shorted. The Prove status has no effect on System output. See "Prove Wiring" on page 19.

- If the Prove input was opened, the control shall turn all the stages off. In addition, it will display a message indicating this status. See "Display Messages" on page 24.
- DHW (Domestic Hot Water) options are used when the heating system provides domestic hot water in addition to building heat. These options control the System output and the target temperature during a DHW Call. on a DHW Call, the Multi-MOD Platinum raises the target to the DHW Set Point. The Multi-MOD Platinum will display a message indicating the DHW Call and the new target. See "Display Messages" on page 24 and See "DHW Set Point" on page 29.
- The DHW No Priority option allows the System output to remain energized during a DHW call. However, during Shutdown, Summer, or when Outdoor Cutoff situations a DHW Call will keep the System output off. When the DHW call ends, all active stages will modulate down then turn off.
- The DHW With Priority option turns off the System output during a domestic hot water call for a priority period of one hour. If after the priority period the DHW call is still active, the System output will energize and the DHW Set Point will remain as the target until the DHW Call ends.
- The DHW Using System option is similar to the DHW No Priority option in that it allows the System output to remain energized during a DHW call. However, during Shutdown, Summer, or when Outdoor Cutoff situations a DHW Call will turn the System output on. When the DHW call ends, all active stages will modulate down then turn off. The System output will turn off after the Run-On period.

**⚠ WARNING**

When prove is selected, do not remove the factory installed Prove jumper unless it is replaced by a prove signal.

If the Prove input is not closed/shorted, the Multi-MOD Platinum will NOT activate the stages.

The Prove input cannot be used as a safety limit. All equipment must have its own certified limit and safety controls as required by code.

## DHW SET POINT

(Available with any of the DHW Priority Options Only)

Adjustable from 140°F/60°C to 200°F/93°C

Default: 180°F/82°C

PRESS TO SELECT: /<System Startup>/ Sensor Type/.../ Prove-DHW/DHW Set Point

- This set point is used as the system target during DHW Calls. See "Prove/DHW Mode" on page 28.



## SENSOR FAULT

Shutdown, All On

Default: All On

PRESS TO SELECT: /<System Startup>/ Sensor Type/.../ Prove-DHW/Sensor Fault Mode

- The Sensor Fault determines the operating status of all output stages that are set to Auto when a sensor reads *Short* or *Open*.

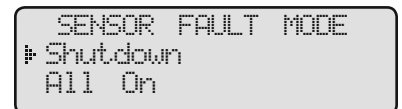

## Set Point Mode

- When All-On is selected, the Multi-MOD Platinum will turn all stages set to Auto to 100% firing when the System sensor reads *Short* or *Open*.
- When Shutdown is selected, the Multi-MOD Platinum will turn all stages Off when the System sensor reads *Short* or *Open*.
- The Outdoor Sensor *Short* or *Open* status will not allow the Outdoor Cutoff to function in Set Point mode. In this case, the control will modulate the boilers to maintain the Set Point.

## Reset Mode

- When All-On is selected, the Multi-MOD Platinum will turn all stages On to a 100% when the System sensor reads `Short` or `Open` and the outdoor temperature is below Outdoor Cutoff. If the outdoor temperature was above the Outdoor Cutoff; the Season was set to Summer; or the Shutdown was active, the Multi-MOD Platinum will turn all the stages off.
- When Shutdown is selected, the Multi-MOD Platinum will turn all stages Off when the System sensor reads `Short` or `Open`.
- When All-On is selected, the Multi-MOD Platinum will maintain the Minimum Target temperature when the Outdoor reads `Short` or `Open`.
- When Shutdown is selected, the Multi-MOD Platinum will maintain the Maximum Target temperature when the Outdoor reads `Short` or `Open`.

## FAST COOL DOWN

(Available with Reset Modes Only)

Minimum Water Temperature, No Heat

Default: Minimum Water Temperature

PRESS TO SELECT: `/<System Startup>/ Sensor Type/.../Sensor Fault Mode/ Fast Cool Down`

- The Fast Cool Down allows the building to cool down quicker when starting the Night Schedule. It does that by lowering the target temperature until the Space Average drops to the Night Target.
- For the Fast Cool Down to function, the Space Lock must be set to ON. See "Space Lockout" on page 45.
- When Minimum Water Temp is selected, the Multi-MOD Platinum reduces the target temperature to the Minimum Target temperature when the Schedule switches from Day (Normal) to Night (Saving). This option must be selected when the boiler manufacturer has a minimum boiler temperature requirement.
- When Off is selected, the Multi-MOD Platinum reduces the target water temperature to a minimum of 70°F when the Schedule switches from Day (Normal) to Night (Saving).
- When the building space temperature reaches the Night Target setting the Multi-MOD Platinum will exit the Fast Cool Down operation and start its night heating level.

```
- FAST COOL DOWN -
# Minimum Water Temp
No Heat
```

## DAY LIGHT SAVING

Enable or Disable

Default: Enable

PRESS TO SELECT: `/<System Startup>/ Sensor Type/.../ Fast Cool Down/Day Light Saving`

- Enable this feature to account for the time changes in areas where Day Light Saving is observed.

```
DAY LIGHT SAVINGS
# Enable
Disable
```

# SYSTEM SETTINGS MENU

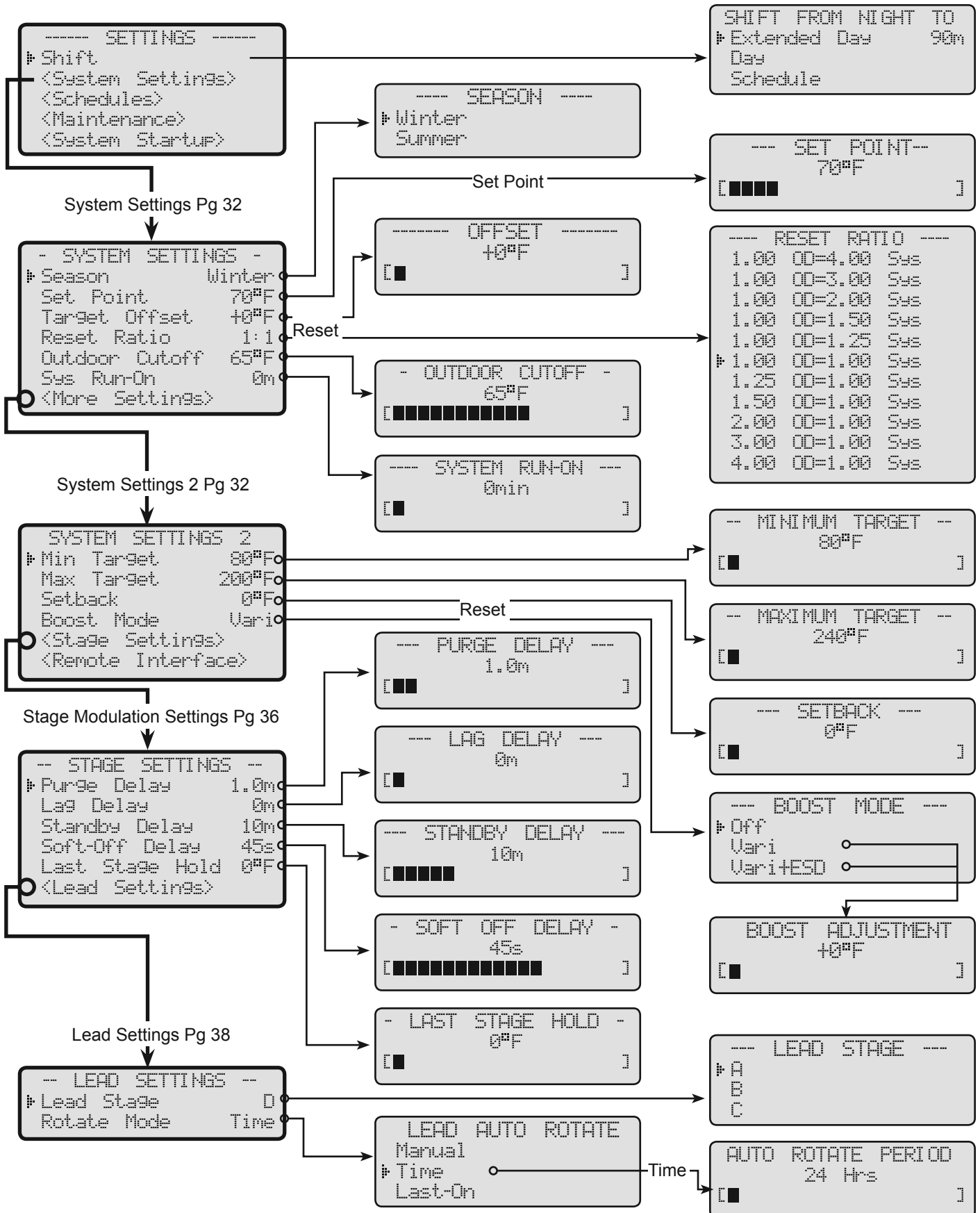

HT# 059299-00 A

# SYSTEM SETTINGS

PRESS TO SELECT: /<System Settings>

- System Settings menus adjust and fine-tune the system to match the building or application specific characteristics for enhanced comfort and more fuel savings.

## SEASON

Winter or Summer

PRESS TO SELECT: /<System Settings>/Season

PRESS TO SELECT: /Season

Default: Winter

when in Winter setting

when in Summer setting

- The Season is used to turn off the outputs when in the off-season period. When Heating is selected as the Heat/Cool Mode, the outputs are turned off when the Season is set to Summer. However, when Cooling is selected, the outputs are turned off when the Season is set to Winter.
- When in the off-season period, it is a good practice to switch the Multi-MOD Platinum to the proper season setting instead of turning the control off.



## SET POINT

(Available Only when Sensor Type is set to °F, °C, or any of the Pressure options)

For Sensor Types, their Ranges, and Defaults see "Sensor Type Table" on page 26

PRESS TO SELECT: /<System Settings>/ Set Point

- The Multi-MOD Platinum modulates the stages to maintain the system temperature/pressure around the Set Point.
- The system is expected to fluctuate around the set point. The amount of fluctuation depends on the control settings.
- If the EMS Mode was Enabled, the Set Point will be set by the EMS/BMS system and will be available as a read only.



## OUTDOOR CUTOFF TEMPERATURE

Adjustable from 20°F/-7°C to 100°F/38°C, Off, On

Default: 65°F/18°C

PRESS TO SELECT: /<System Settings>/ Set Point

- This feature turns off the outputs when the outdoor temperature rises above the Outdoor Cutoff in Heating Mode. In Cooling Mode, it turns off the outputs when the outdoor temperature drops below the Outdoor Cutoff. See "Heat/Cool Mode" on page 28.
- In addition to the operable temperature range, the Outdoor Cutoff can be set to ON or OFF. If ON was selected, the control will modulate the stages to hold the target set point regardless of the outdoor temperature. The System output will be active at all times.
- If OFF was selected, the System output and all the stages will be off.



## OUTDOOR RESET SETTINGS

(Available Only when Sensor Type is set to Reset °F or Reset °C)

- Outdoor Reset adjusts the target temperature based on the outdoor temperature. See "Reset Ratio/Outdoor Reset" on page 5.
- The target temperature value depends on the following settings:
  - Reset Ratio
  - Minimum Target
  - Target Offset
  - Maximum Target

HT# 059299-00 A



## RESET RATIO

Adjustable from 1.00°OD:4.00°Sys to 4.00°OD:1.00°Sys Default: 1.00°OD:1.00°Sys  
 PRESS TO SELECT: /<System Settings>/ Reset Ratio

- The Reset Ratio adjusts the system target temperature based on the outdoor temperature. See "Suggested Reset Settings" on page 6.
- It uses a system water temperature of 100°F and an outdoor temperature of 70°F as the reset ratio beginning point. With a 1.00 (OD):4.00 (Sys) ratio, the System water temperature (Sys) will increase rapidly as the outside temperature falls, hitting 220°F at 40°F outside temperature. With a 4.00 (OD):1.00 (SYS) ratio, the System temperature (SYS) will increase slowly as the outside temperature falls. Even at -10°F outdoor temperature, the system water will only be 120°F. Such a low Reset Ratio might be used with radiant floor heating applications.
- With most baseboard heating applications, a 1.00 (OD):1.00 (SYS) setting is a good place to start.
- If required: **Adjust the Reset Ratio in cold weather.** If the ambient building temperature is cold, move the ratio to a higher selection. That is, if 1.00 (OD):1.00 (SYS) was initially selected, change the selection to 1.00 (OD):1.25 (SYS). If the building temperature is too warm, move the ratio to a lower selection. That is, if 1.00 (OD):1.00 (SYS) was initially selected, change it to 1.25 (OD):1.00 (SYS).
- After changing the Reset Ratio, wait at least 24 hours before making any additional adjustments.

```

    ----- RESET RATIO -----
    1.00 OD=4.00 Sys
    1.00 OD=3.00 Sys
    1.00 OD=2.00 Sys
    1.00 OD=1.50 Sys
    1.00 OD=1.25 Sys
    1.00 OD=1.00 Sys
    1.25 OD=1.00 Sys
    1.50 OD=1.00 Sys
    2.00 OD=1.00 Sys
    3.00 OD=1.00 Sys
    4.00 OD=1.00 Sys
    
```

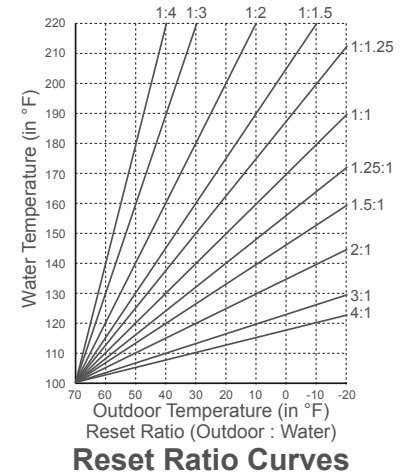

## TARGET OFFSET

Adjustable from +40F/+22C° to (-40F/-22C°) Default: 0F°/0C°  
 PRESS TO SELECT: /<System Settings>/ Reset Ratio

- The Offset setting moves the Reset Ratio curve vertically. This means that, regardless of the outdoor temperature, or the Reset Ratio selected, when the Offset setting is changed, that change is directly added to or subtracted from the calculated temperature. For example, if the target temperature was 130°F and the Offset was changed from 0° to 10° (an increase of 10°), the Set Point would increase to 140°F.
- If required: **Adjust the Water Offset in mild weather.** If the ambient building temperatures are too warm in the mild weather, decrease the Offset. If the ambient building temperatures are too cold in the mild weather, increase the Offset.
- The rule of thumb for baseboard radiation is to change the Offset 4°F for every 1°F you wish to change the building temperatures.
- In radiant heat applications, change the Offset 1°F or 2°F for every 1°F you wish to change the building temperature.

```

    ----- OFFSET -----
    +10°F
    
```

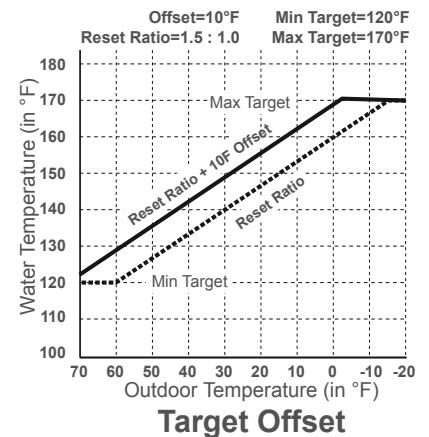

## MINIMUM TARGET

Adjustable from 70°F/21°C to 170°F/77°C Default: 70°F/21°C  
 PRESS TO SELECT: /<System Settings>/<More Settings>/Min Water Temp

- The Minimum Target temperature is the lowest temperature the control will use as a target. Primarily, it is used to protect non-condensing boilers from extended periods of low temperature.
- This value must be set to the boiler manufacturer's specification.

```

    ----- MINIMUM TARGET -----
    80°F
    
```

## MAXIMUM TARGET

Adjustable from 90°F/32°C to 240°F/115°C

Default: 240°F/115°C

PRESS TO SELECT: /<System Settings>/<More Settings>/Max Water Temp

- The Maximum Target is the highest water temperature the control will circulate through the heating system. It is used to protect system components from excessive hot water temperatures.
- When using an in-floor radiation system, the Maximum Target should be set according to the tubing or floor manufacturer's specification.

## SYSTEM RUN-ON

Adjustable from 0 to 360 minutes

Default: 0 minutes

PRESS TO SELECT: /<System Settings>/Sys Run-On

- The System Run-On delays turning off the system pump to help disperse residual stage energy into the system.
- The System Run-On starts after the last Stage output is turned off when no outdoor sensor is available.
- When an outdoor sensor is available, the run-on starts when any of the Outdoor Cutoff, off-season, or Shutdown starts.
- The System output relay will remain active whenever the outdoor temperature is below the Outdoor Cutoff in heating. However, when the outdoor temperature rises 2°F above the Outdoor Cutoff, the System output will remain energized for the Run-On period before turning off.

## SETBACK

Adjustable from 0F°/0C° to 80F°/44C°

Default: 0F°/0C°

PRESS TO SELECT: /<System Settings>/<More Settings>/Setback

- The Setback lowers the temperature/pressure target when less load is required or during the Night Schedule.
- In Heating mode the Setback value is subtracted from the target. However, it is added to the target when in Cooling mode.
- The Setback is triggered in one of two ways, when a dry-contact input is connected to the EMS terminals. See "Setback Wiring" on page 20.
- Also, the Setback is triggered during the Night Schedule settings. See "Schedules" on page 42.

## BOOST AND EARLY SHUTDOWN

Off, Vari, Vari+ESD

Default: Vari

Vari is adjustable from 0F°/0C° to 60F°/33C°

Default: 0F°/0C°

PRESS TO SELECT: /<System Settings>/<More Settings>/Boost Mode

- The Vari-Boost returns the building to day ambient temperatures after the cooler Night Schedule (Setback) period much faster. It accomplishes this by running elevated water temperatures for a calculated period based on the #1 Day Time schedule and the outdoor temperature.
- If no Space Average exists, the Boost ends at the #1 Day Time.
- If Space Average exists, the Boost ends when the Space Average reaches the Day Target. If the Day Target was not reached by the #1 Day Time, the Boost may extend up one hour into the Day schedule.



**WARNING**

The limits set on the boilers **MUST** be set considerably higher than the Multi-MOD's Set Point for the following reasons:

- The System sensor is located in the common header some distance from the boilers. Therefore, the temperature in the header will be lower than that in the boilers.
- In addition the Last-Stage-Hold setting must be accounted for. The boiler limit must be set above the Set Point **PLUS** the Last-Stage-Hold **PLUS** the normal temperature drop experienced in the piping.

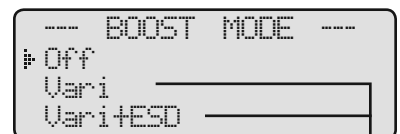
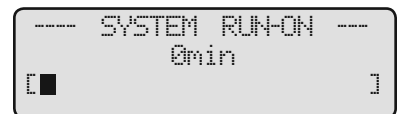

- To exclude the Boost on a specific day of the week, simply do not use the #1 Day Time schedule. See "Schedules" on page 42.
- When in Boost, the control displays a message indicating it. See "Display Messages" on page 24.
- The Early Shutdown (ESD) is used to switch to Night earlier than the last Night Schedule. The control does that by starting to change the target temperature to the Fast Cool Down setting earlier than the last Night Time based on the outdoor temperature.
- If no Space Average exists, the ESD ends at the last Night Time schedule.
- If Space Average exists, the ESD ends when the Space Average drops below the Night Target.
- When in ESD, the control displays a message indicating it. See "Display Messages" on page 24.

## Boost Modes

**Off** - Boost is always disabled.

**Vari-Boost** - This Boost begins earlier than the Day # 1 time. The length of the Boost time depends on the outside temperature. During the Boost period, the Multi-MOD Platinum increases the target temperature by the number of degrees set by the Boost Adjustment.

- If the ambient building temperatures are too cold at the Day # 1 time, then increase the Boost Adjustment in increments of 10°F. If the Boost Adjustment is turned all the way up, and it is still too cold at the Day # 1 time, it might be necessary to reduce the Setback setting. See "Setback" on page 34.
- If it is too warm at the Day # 1 time, then decrease the Boost Adjustment in increments of 10°F

**Vari-Boost with ESD (Early Shutdown)** - This feature is used in commercial buildings where the building is unoccupied at night. The Vari-Boost runs as indicated above. In addition, the ESD switches the Schedule to the Night earlier than the latest Night setting.

- The warmer it is outside, the earlier the Multi-MOD Platinum shifts to the Night setback.
- During the Early Shutdown the Multi-MOD Platinum uses the Fast Cool Down setting as the target temperature.
- If the Multi-MOD Platinum has an Internet communication package and Space Lockout has been activated, the Early Shutdown will lower target temperature to either Minimum Water Temp setting or 70°F, depending on the Fast Cool Down setting, until the Space Average has reached the Night Target.
- If Space Lockout has not been activated or no communication package is available, the Target temperature will be the Night Setback.

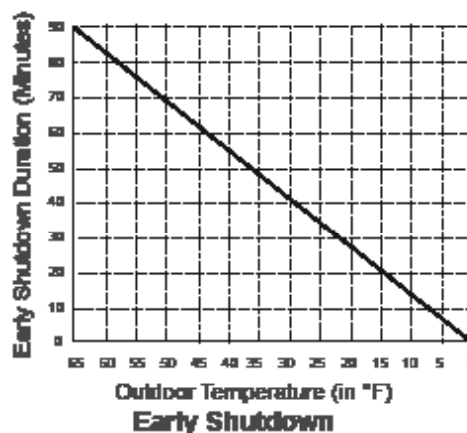
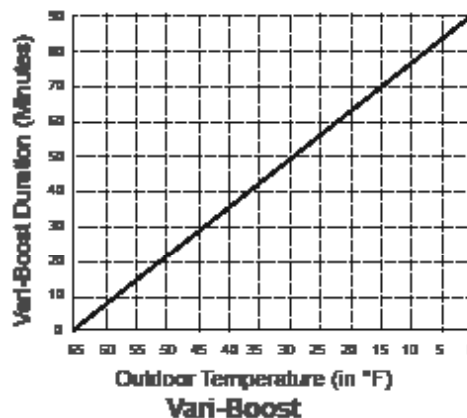

# STAGE MODULATION

## GAIN

Adjustable from -10 to +10  
Adjustable from 1.0 to 10.0

Default: 0 in Normal Operating Mode  
Default: 5 in Process Operating Mode

PRESS TO SELECT: /<Maintenance>/ Gain



### Normal Operating Mode

- In this Mode, the Gain adjusts the modulation aggressiveness of the control PID logic. See "Operating Mode" on page 28.
- A Gain of 0 is a good starting point for all systems.
- If during normal load conditions, the system temperature/pressure tends to oscillate significantly, decrease the Gain by two numbers (for example, from 0 to -2).
- If during normal load conditions the system temperature/pressure tends to remain consistently below the Set Point (or consistently above the Set Point), increase the Gain by two numbers (for example, from 0 to 2).
- After each change wait for at least 15 minutes before evaluating the change's effect on the system.

**ALERT**

The Process Gain Table does not show all the possible modulation values. The table is for example only. The Multi-MOD Platinum will control the modulation in one percent increments based on the target and Gain.

### Process Operating Mode

- In this mode, the Gain acts as a throttling range around the target. See "Operating Mode" on page 28.
- When the actual temperature/pressure is equal to the target, only the lead stage is on at 100% modulation.
- Each Gain range above or below the target controls one stages modulation linearly from 0 to 100%.
- The Process Gain Table below shows the relationship between the Gain and stage modulation.

**PROCESS GAIN TABLE**

System Temperature	Stages Modulation
More than 1 x Gain above Set Point	Lead Stage is OFF
1 x Gain above Set Point	Lead Stage at 1%
0.5 x Gain above Set Point	Lead Stage at 50%
At Set Point	Lead Stage at 100%
0.5 x Gain below Set Point	Lead Stage at 100%, 1 Lag at 50%
1 x Gain below Set Point	Lead Stage at 100%, 1 Lag at 100%
2 x Gain below Set Point	Lead Stage at 100%, 2 Lag at 100%
3 x Gain below Set Point	All Stages at 100%

## PURGE DELAY

Adjustable from 0.0 to 10.0 minutes

Default: 1.0

PRESS TO SELECT: /<System Settings>/<More Settings>/Purge Delay

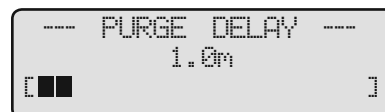

- The Purge Delay is designed to match the boilers purge period before it is brought on line and can begin generating output.
- When activating a new stage, the Multi-MOD Platinum holds its modulation at the Ignition % until the Purge Delay ends. Once the Purge Delay is over, the control begins adjusting its modulation.
- Set the Purge Delay according the stage's manufacturer specification.

HT# 059299-00 A

## LAG DELAY

(Not Available in Process)

Adjustable from 0 to 60 minutes

Default: 0.0min

PRESS TO SELECT: /<System Settings>/<More Settings>/Lag Delay



- The Lag Delay is designed to delay the lag boiler activation while the lead boiler is at full firing rate for an adjustable period. This is useful when the lead boiler can satisfy the load requirement.
- The Lag Delay requires the previous stage to remain at 100% modulation for the full Lag Delay period before another stage can be activated. For example, if the Lag Delay is set to 10 minutes, the lead stage must remain at 100% modulation for a full ten minutes before the lag stage is activated.

## STANDBY TIME

(Not Available in Process)

Adjustable from 0 to 60 minutes

Default: 10 minutes

PRESS TO SELECT: /<System Settings>/<More Settings>/Standby Time



- The Standby Delay is primarily used to delay the backup/standby boilers firing. The standby group can only be started after the rest of the boilers are at full fire for the Standby Delay period. See "Mode" on page 39.
- A shorter Standby Time results in smoother set point operation in extreme conditions. Longer Standby Time may prevent a Standby boiler from starting if the other boilers can eventually meet the load or if the load decreases.

## LAST-STAGE-HOLD

(Not Available in Process)

Adjustable from 0F°/0C° to 30F°/17C°

Default: 0F°/0C°

PRESS TO SELECT: /<System Settings>/<More Settings>/Last-Stage-Hold



- The Last-Stage-Hold prevents short cycling of the lead stage during low load conditions. This happens when the system has a load that is significantly less than the minimum output of one stage. When the lead stage is turned on, the target is quickly exceeded, and the lead stage is turned off. To prolong the runtime and off time during this type of condition, use the Last-Stage-Hold setting. The Last-Stage-Hold allows the lead stage to stay on longer. And thus it will stay off longer.
- For example, with a minimum target of 140°F and a Last-Stage-Hold setting of 10°F, the lead stage will remain on until the Set Point reaches 150°F. During that period, the display will show "Hold Until 150F" then, the lead stage will turn off

## SOFT-OFF DELAY

Adjustable from 0 to 60 seconds

Default: 45 seconds

PRESS TO SELECT: /<System Settings>/<More Settings>/Soft-Off Delay



- When a stage is no longer needed, the Soft-Off Delay keeps that stage at low fire prior to turning it off. This helps reduce the stage short cycling.
- If during the Soft-Off Delay the control needed that stage, the stage is released from the Soft-Off Delay and will resume normal operation.
- The control will display a blinking Ignition % to indicate that the stage is in Soft-Off Delay.

## MODULATION SPEED

(Available in Process Mode Only)

Adjustable from 0.1 to 6.0 minutes

Default: 0.1 minutes

PRESS TO SELECT: /<Maintenance>/Mod Speed

- Modulation Speed is designed to match the burner modulating speed to the Multi-MOD's logic. This helps the Multi-MOD Platinum to respond accurately to system changes. See "Operating Mode" on page 28..

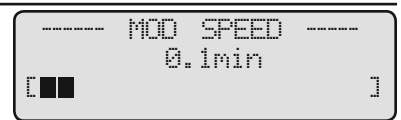

### ALERT

Adjust the Modulation Speed to the motor with the slowest modulation.

## LEAD STAGE ROTATION

PRESS TO SELECT: /<System Settings>/<More Settings>/<Stage Settings>/<Lead Settings>

- The Lead Stage is the first stage brought on when output is required.
- Rotating the lead stage evens the wear on each stage and prolongs the life of the units.
- Only stages their Mode is set to Auto can be Lead. Therefore, not all stages may be available when manually selecting a new lead stage.
- The current Lead Stage is shown in brackets on the display. <A>



## LEAD STAGE

Adjustable from A through D

Default: A

PRESS TO SELECT: /<System Settings>/.../<Stage Settings>/<Lead Settings>/Lead Stage

- Select a new lead stage from this menu. This menu option is primarily used with Manual rotation option to select the lead stage.



## LEAD AUTO ROTATE

Manual, Time, Last-On

Default: Time

Time is adjustable from 1 hour to 999 hours

Default: 24 hours

PRESS TO SELECT: /<System Settings>/.../<Stage Settings>/<Lead Settings>/Rotate Mode

- Automatically rotating the lead stage promotes even wear on all the stages and prolongs their lives.

### Manual

- In Manual, No rotation of lead stage. Select the lead stage manually from the previous menu.



### Time

- Timed rotation starts the lead stage followed by the lag stage. When turning stages off, it turns off the lag stages before the lead stage. Example: If stages "<A>", "B", and "C" are on while "<A>" is the lead, then when turning off the stages it will turn off stage "C" followed by "B" and then finally "<A>".
- If 24 Hours (default setting) was selected, the first rotation will take effect after 12 hours. The following rotations will take place every 24 hours thereafter. However, if Time rotation was set to other than 24 hours, the rotation timer will start from the moment the setting is changed.

### Last on

- Unlike Time rotation, Last-On turns off the last stage turned on last. Example: If "<A>" is the lead, the starting sequence of the boilers will be "A", "B", then "C". When the turning off the stages, it will turn off "A", "B", followed by "C". Then, "<D>" will be the new lead stage.

# STAGE SETTINGS

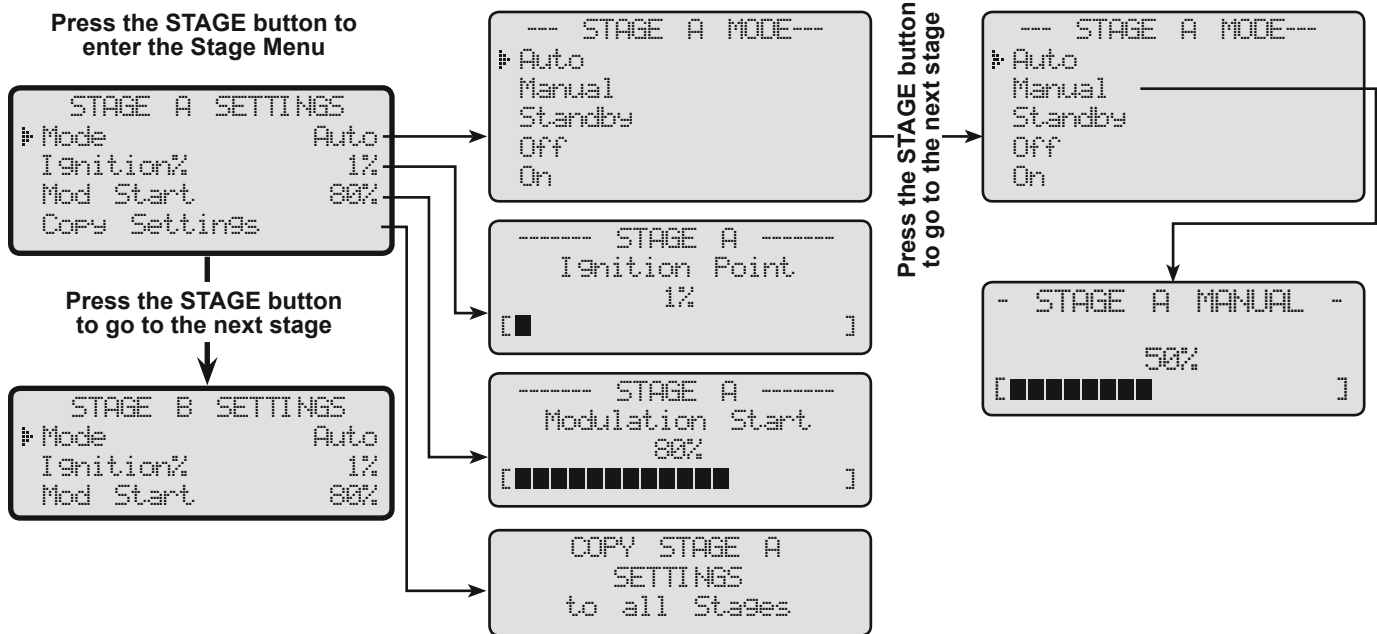

## STAGE MENU

STAGE: STAGE MENU

- This menu helps set the total number of active stages. In addition, it offers the option to adjust the low fire setting and the lead percent firing at which the lag stage starts.
- In most installations, all stage adjustments are the same. However, the Multi-MOD Platinum offers a customized adjustment for each stage to satisfy installations with different types of boilers.
- When all the stages are the same type of boiler, configure Stage "A" settings then copy the settings to the rest of the stages. Everything but the Mode will be copied.

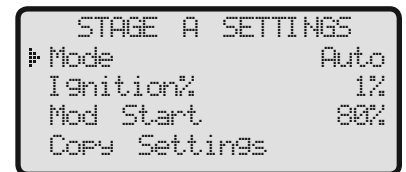

## MOVING AROUND THE STAGES MENUS

- Pressing the Stage button scrolls through the Stages' menus.
- Pressing the Next button displays the next adjustment.

## MODE

Auto, Standby, Manual, Off, On

Default: Auto

STAGE: STAGE MENU/Mode

- The Multi-MOD Platinum only controls the modulation of stages set to Auto or (after a delay) those set to Standby. None of the other settings are recommended for stages connected to active units.

### Auto

- The Multi-MOD Platinum controls the stage's operation to maintain the target.
- Only stages set to Auto can be lead stages.

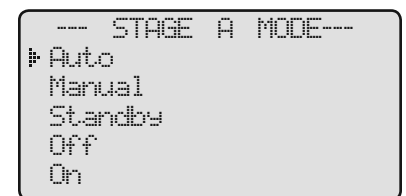

## Standby

- Standby stages are used as back stages in extreme load conditions.
- Standby stages can only be activated after all stages in Auto have been at 100% modulation for the Standby Delay.
- A Standby stage can never be a lead stage.

## Manual

- This mode should only be used to test the stage. Manual overrides the System Prove input. The exact percent of modulation for a stage can be set with the Manual mode. Once selected, the unit will immediately turn on and modulate to the selected percentage. The stage status will indicate 50% for the manually set stage.

## Off

- Any stage without a relay or not connected to a physical unit should be set to Off.
- The Off Mode is also used to disable stages that are in service.

## On

- The On mode should only be used when testing a stage. This mode overrides the System Prove input. Stages set to On will immediately modulated to 100%.

## IGNITION %

Adjustable from 1 to 100%

Default: 1%

STAGE: STAGE MENU/Ignition %

- The Ignition % is the minimum modulation percent for the stage to be activated. See "Modulation Concept" on page 4.
- The Ignition % is maintained during the Purge Delay, Soft-Off Delay, and Last-Stage-Hold.
- For most modern power draft units, the Ignition % can be set to 1%. Other units or atmospheric units may require their modulating to be from 20-50% before the stage can be active. Check with the equipment manufacturer for the minimum firing rate required.

**⚠ WARNING**  
Manual and On Stage Modes activate the stages regardless of the Prove input signal. Do not use the Manual or On options unless all safety controls are checked and adjusted to avoid hazard situations.

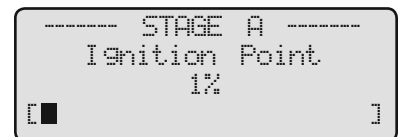

## MODULATION START

Adjustable from 0 to 99%

Default: 80%

STAGE: STAGE MENU/Mod Start %

- The Modulation Start is the modulation percent at which the lag stage can be activated. See "Modulation Concept" on page 4.
- For example, if the Modulation Start for Stage "B" is set to 75%, then when Stage "A" reaches 75% modulation, Stage "B" is turned on.
- When modulation is decreasing, the lag unit will remain at the Ignition % until the lead stage reaches 40% of its Modulation Start, or 2% above the Ignition Point, whichever is higher.





- Using the same example, as the load decreased, Stage "B" would modulate down to its Ignition %. Stage "A" would then modulate down to 30%. Only then, Stage "B" turns off.
- If the Lag Delay is set to anything other than 0, a stage must always go to 100% modulation before the next stage is activated. However, the Modulation Start should still be set correctly as it is used during modulation reduction.
- The Modulation Start will generally be set differently based on the Modulating Mode:

### Modulating Mode - NORMAL

- Lower Modulation Start setting allows the lag boiler to be activated and warmed up early for smoother output and better target control.
- Higher Modulation Start settings can prevent unnecessary stages from being activated.
- Some general guidelines to follow:
  - Less than 50% - not recommended in the Normal Modulating Mode.
  - 50-70% - These lower settings might be used in an application that has wide load swings such as an industrial plant or a hospital. This allows an additional boiler to be brought on line before the previous boiler has begun to reach its capacity.
  - 70-90% - This range is recommended for most applications. When there are several stages of relatively equal capacity and all can be used to hold the load, this allows some degree of overlap, without activating unnecessary stages.
  - 90-100% - Recommended when one stage can always handle the load while the other stages are mainly used for backup.

### Modulating Mode - PARALLEL

- The Modulation Start should be set to the maximum value where the unit runs most efficient.
  - Less than 30% - These lower settings are recommended for condensing boilers with high turn-down ratios of 4 to 1 or greater.
  - 30-50% - These settings are recommended for the rest of all condensing boilers.

### COPY SETTINGS (STAGE A ONLY)

STAGE: STAGE MENU/ Copy Settings

- This option copies only the Ignition % and Modulation Start from stage "A" to the rest of the stages.

COPY STAGE A  
SETTINGS  
to all Stages

 **ALERT**  
The Mode must be set for each stage. The Copy Settings command will not set the Mode for the rest of the stages.

HT# 059299-00 A

# SCHEDULES MENU

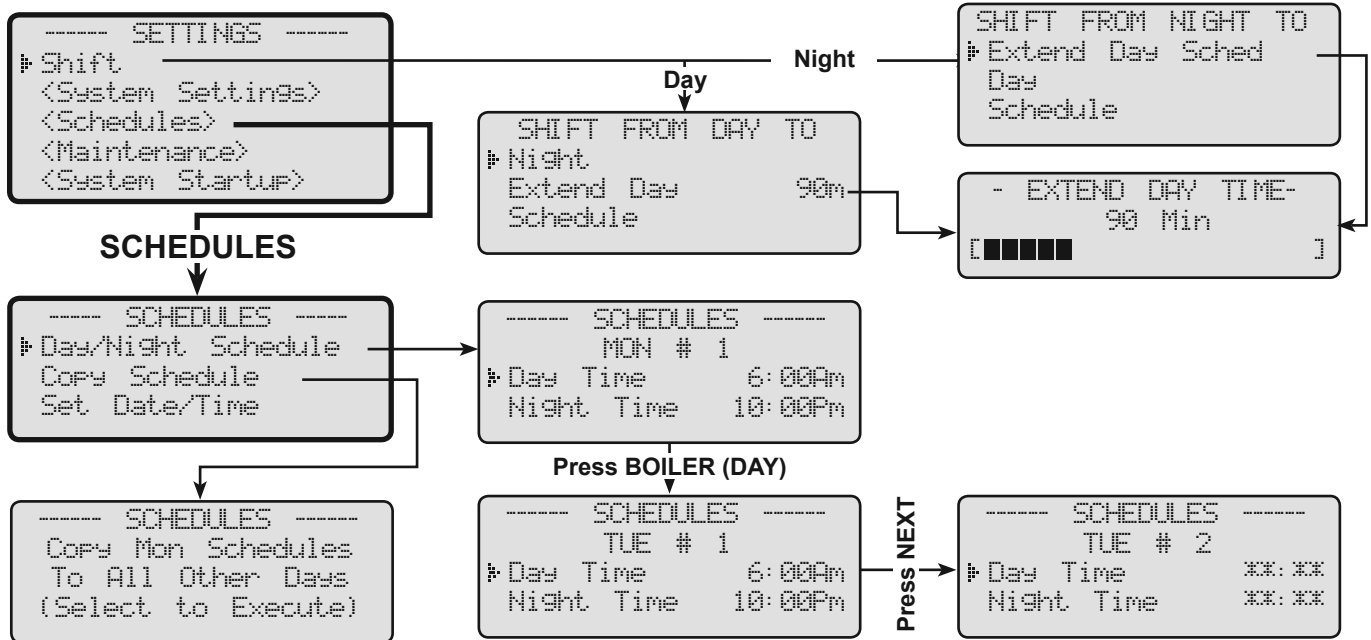

## SCHEDULES

PRESS TO SELECT: /<Schedules>

- The Multi-MOD Platinum has two levels of heat. The Day Time level is used when a building is occupied and people are active. The Night Time (Setback) level is used when a building is unoccupied or when people are sleeping.
- The Multi-MOD Platinum has four Day Time and four Night Time (Setback) periods for each day of the week (Mon#1, Mon#2, Mon#3, and Mon#4). The display Message Line will indicate that using either "Day" or "NGT".
- If an office building is unoccupied all weekend, simply set the latest Friday Night Time and delete all Saturday's and Sunday's schedules. A deleted Time displays (\*\*.\*\*). The control will stay in Night Time (Setback) until it reaches a Day setting on Monday.
- Day Time #1 setting for each day is used to calculate and end the Boost. See "Boost and Early Shutdown" on page 34.
- The latest Night Time setting for each day is used to calculate and end the ESD. See "Boost and Early Shutdown" on page 34.

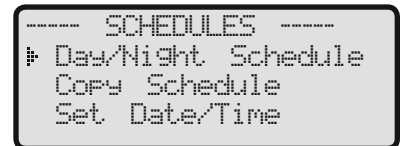

**ALERT**

The Multi-MOD Platinum ignores any Time setting that reads \*\*.\*\*.

The #1 Day setting for any Day Time is used by the Boost. The last chronological Night Time setting is used by the ESD.

## SHIFT

Day, Night, Extended Day, Schedule

Extended Day is adjustable from 60 to 240 minutes

PRESS TO SELECT: /Shift

Default: Day

Default: 90 minutes

- The Shift changes the current schedule time from Day to Night or visa versa. This can be used to temporarily override the programmed schedule. A typical example where the shift would be used is in a school where an event has gone into overtime. Instead of re-programming the control to keep it from going into the Setback mode, simply use the Shift.

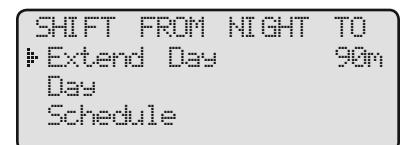
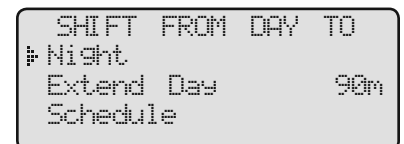

### Shifting from Night to Day

- The control uses the Day settings instead of the current Night settings. The control stays in the Day mode until the control is shifted again or until the next programmed Night Time. The display will show "DAY SHF" to indicate this status.

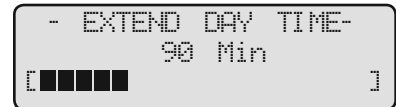

### Shifting from Day to Night

- The control uses the Night settings instead of the current Day settings. The control stays in the Night mode until the control is shifted again or until the next programmed Day Time. The display will show "NGT SHF" to indicate this status.

### Shifting to Extended Day

- The control uses the Day settings for an extended period. The extended period is set by the Extend Day Time. The display will show "DAY EXT" to indicate this status. When the control is manually shifted to Extended Day, the Display will alternate between the "DAY EXT" and the remaining extended time balance in minutes "DAY 89" to indicate this status. After the extended period, the control reverts to the schedule.
- The Shift to Extended Day option is available to anyone with access to the control. A Password restriction does not affect this option.

### Shifting to Schedule

- This option exists the Shifting and resumes the scheduled operation.
- The Shift to Schedule option is available to anyone with access to the control. Password restrictions does not affect this option.

## DAY/NIGHT SCHEDULE

Day Time #1, Night Time #1

Default: 6:00 Am, 10:00 PM

Day Time #2, #3, #4, and Night Time #2, #3, #4

Default: \*\*.\*\*

PRESS TO SELECT: /<Schedules>/Day Night Schedule

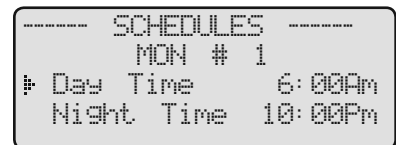

- Use this setting to set up to 4 Day Time and 4 Night Time (Setback) settings per each day of the week.
- If the Boost feature is being used, it uses the Day Time #1 setting. See "Boost and Early Shutdown" on page 34.
- The Night Time setting reduces the target temperature by the Setback setting. Furthermore, if the ESD is used, the control uses the last Night Time in calculating the ESD.

### Schedule Example

Schedule	Day of Week							
	MON	TUE	WED	THU	FRI	SAT	SUN	
#1	Day	6:00AM	6:00AM	6:00AM	6:00AM	7:00AM	***	***
	Night	10:00PM**	10:00PM**	10:00PM**	10:00PM**	11:00AM	***	***
#2	Day	**.*	**.*	**.*	**.*	1:00PM	8:00AM*	***
	Night	**.*	**.*	**.*	**.*	4:00PM	4:00PM**	***
#3	Day	**.*	**.*	**.*	**.*	6:00PM	**.*	**.*
	Night	**.*	**.*	**.*	**.*	10:00PM**	***	***
#4	Day	**.*	**.*	**.*	**.*	**.*	***	***
	Night	**.*	**.*	**.*	**.*	**.*	***	***

◆ No boost will take effect.

◆◆ Early Shut Down ends. Night Schedule begins

- Monday through Thursday:**
- Vari-Boost begins before 6 am and ends at 6 am
  - Day temperature is maintained from 6 am until before 10 PM
  - Early Shutdown starts before 10 PM and ends at 10 PM
  - Night temperature is maintained from 10 PM until the Vari Boost the following morning

- Friday:**
- Vari Boost begins before 7 am and ends at 7 am
  - Day temperature is maintained from 7 am to 11 am
  - Night temperature is maintained from 11 am to 1 PM
  - Day temperature is maintained from 1 PM to 4 PM
  - Night temperature is maintained from 4 PM to 6 PM
  - Day temperature is maintained from 6 PM until before 10 PM
  - Early Shutdown starts before 10 PM and ends at 10 PM
  - Night temperature is maintained from 10 PM until the following morning

- Saturday:**
- No Vari Boost because the #1 is not programmed
  - Day temperature is maintained from 8 am until before 4 PM
  - Early Shutdown starts before 4 PM and ends at 4 PM
  - Night temperature is maintained from 4 PM into Sunday

- Sunday:**
- Night temperature is maintained all day Sunday, ending at the Vari Boost Monday morning

 **ALERT**

If the control has space sensors configured, Boost can extend to an additional hour if Day Target was not reached within the Boost period.

**COPY SCHEDULE**

PRESS TO SELECT: /<Schedules>/Copy Schedule

- This feature copies all Monday's schedule to the rest of the week.

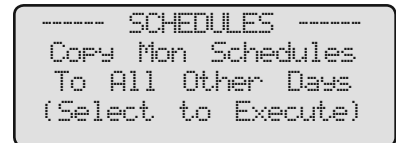

**SET DATE AND TIME**

PRESS TO SELECT: /<Schedules>/Set Date & Time

- To use the schedules, set the Date and Time.
- Internet capable controls get their date and time from the Internet based on the Building Time Zone setting in the ICMS website.

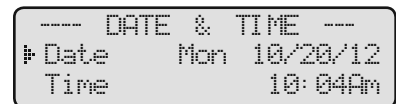

**VACATION SCHEDULE SETTING**

Available in RINet (Internet Controls Only)

- The Vacation Schedule is used to reduce energy usage during holidays. It does that by lowering the space target between two date-time settings.
- The Vacation Space Target and settings can only be set and activated using the ICMS website.
- The Vacation Schedule Enable must be On to set the Vacation Schedule and Space Target.

 **ALERT**

The battery is the only backup for the Date and Time during power outage. The battery can hold the date and time for up to 100 days.

HT# 059299-00 A

# COMMUNICATION MENU

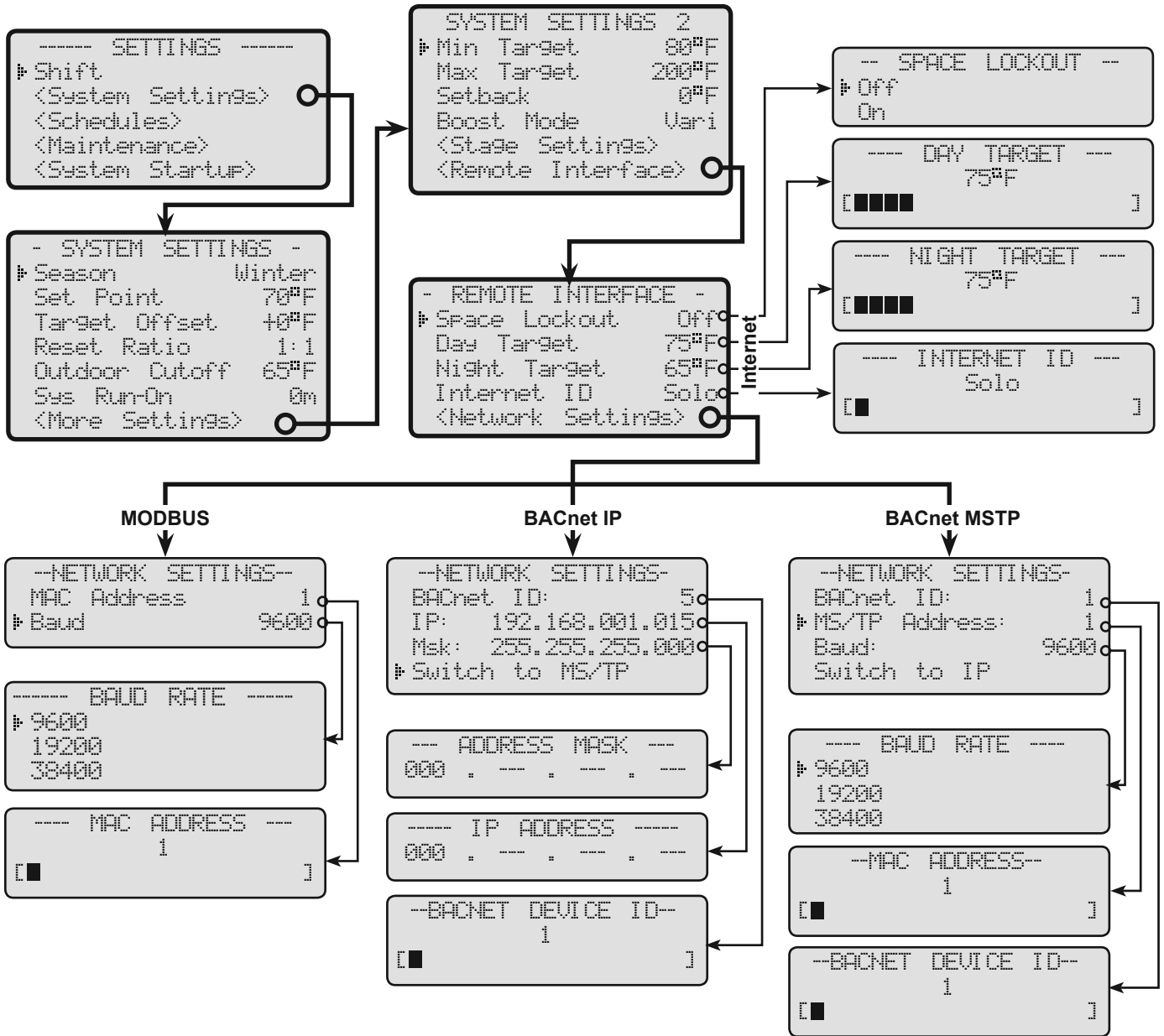

## INTERNET COMMUNICATION

Visit (<http://www.htcontrols.com>)

(Requires Internet Communication Package)

PRESS TO SELECT: /<System Settings>/<More Settings>/<Remote Interface>

- Internet Capable Multi-MOD Platinum controls have remote capabilities, space temperature control, sensor monitoring, alarming, reporting, and much more.

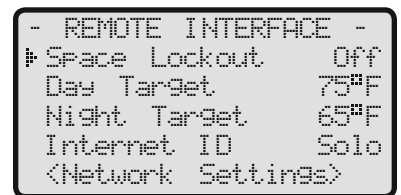

## SPACE LOCKOUT

On or Off

Default: Off

PRESS TO SELECT: /<System Settings>/<More Settings>/<Remote Interface>/Space Lockout

- Space Lockout prevents the control from overshooting the space temperature when in Boost. It does that by ending the Boost when the Space Average reaches the Day Target.

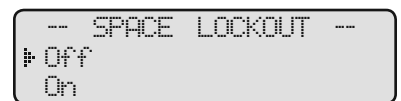

- The Space Lockout also prevents the control from overheating the space temperature when switching from Day Time to Night Time. It does that by using the Fast Cool Down. See "Fast Cool Down" on page 30.

## DAY AND NIGHT TARGET

Day 55°F to 85°F

Night 50°F to 80°F

Default: 75°F

Default: 65°F

PRESS TO SELECT: /<System Settings>/<More Settings>/<Remote Interface>/Day Target



- The Day and Night Targets are the Space Average temperatures that are maintained during the Day Time and Night Time schedules. They are also used by the Space Feedback to adjust the target water temperature using the System Water Offset. In addition, the Day Target is used by the Boost and the Night Target is used by the ESD. See "Boost and Early Shutdown" on page 34.
- If the Boost tends to extend beyond the Day Time #1 setting, the Night Target may be too low. Increase the Night Target 2°F and re-evaluate the Boost history after a few days.



## CHANGE SYS WATER TARGET PER SPACE DEGREE

Accessible Only through the Internet (Requires RINet Package)

0.0 to 5.0

Default: 4.0

- This change is used to fine-tune the reset ratio performance. It does that by adjusting the water temperature hourly based on space temperature.
- Changing the system water target per space degree adjusts the Target Water Temperature for every 1°F the Space Average is away from the Space Target. That is, if the Space Target was 70°F and the Space Average was 68°F, then the control will increase the System Water Offset by 8°F when the Feedback Gain is set to 4°F ((70°F - 68°F) x 4°F = 8°F). This increase in the system temperature allows the building to reach its Space Target quicker. See "Space Feedback Concept" on page 6.
- If the Space Average Temperature tends to oscillate multiple times within the day, reduce the Change System Water Target per Space Degree.
- If the Space Average Temperature never reaches the Day Space target, increase the Change System Water Target per Space Degree.

 **ALERT**

BACnet or MODBUS capable Platinum controls displays --NETWORK PANEL-- on the 2nd row of the display when in screen-saver mode.

## BACNET COMMUNICATION

(Requires BACnet Communication Package)

PRESS TO SELECT: /<System Settings>/.../<Remote Interface>/Network Settings

- The Multi-MOD can be ordered with or upgraded to BACnet IP and MSTP communication capabilities.
- See "BACnet Configuration Manual" for detailed information on setting and using BACnet controls.

## MODBUS COMMUNICATION

- The Multi-MOD can be ordered with or upgraded to MODBUS RTU communication capabilities.

- See "MODBUS Configuration Manual" for detailed information on setting and using MODBUS controls.

HT# 059299-00 A

# MAINTENANCE MENU

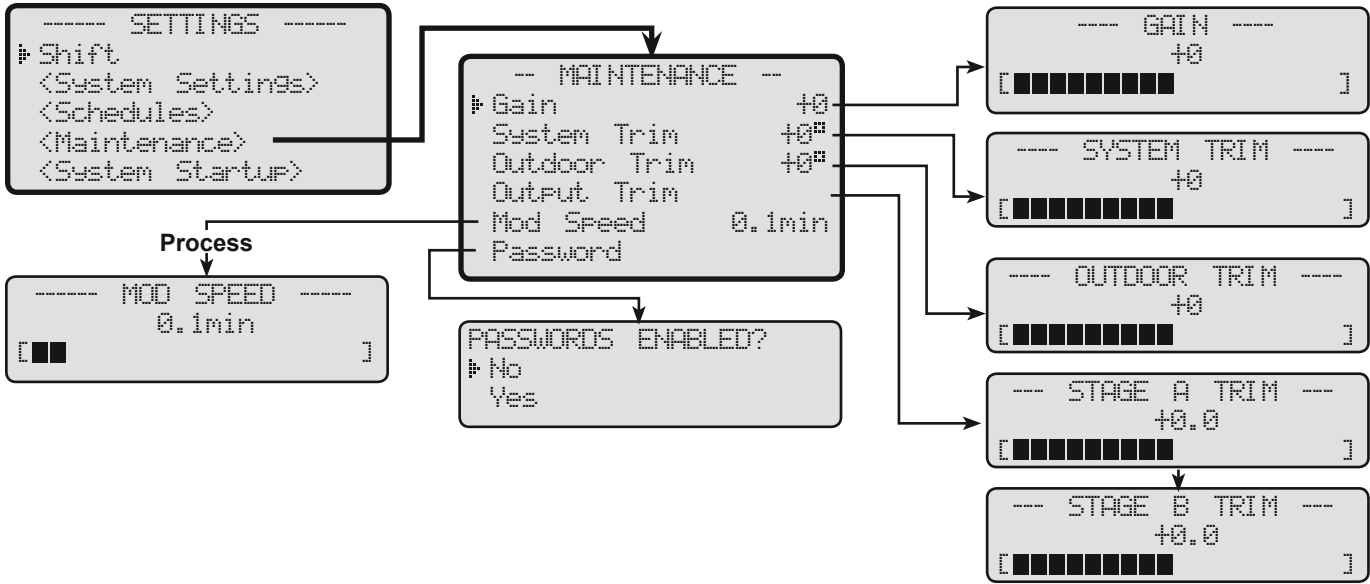

## GAIN

See "Gain" on page 36.

## SYSTEM AND OUTDOOR SENSOR TRIM

Adjustable from -5° to +5°

Default: 0°

PRESS TO SELECT: /<Maintenance>/System Trim or Outdoor Trim

- The Heat-Timer sensors are very accurate, and normally require no calibration. Sometimes it may be desirable to make small adjustments to the displayed value of the outdoor temperature or the System value.
- Do not use the Trim setting to make the outdoor temperature match that reported on the radio or TV. Outdoor temperature can vary widely over a broadcast range. Only trim the outdoor sensor based on an accurate thermometer reading taken where the sensor is located.

Sensor Trim Table

SENSOR TYPE	Trim Range
°F, °C	-5°F to +5°
Reset°F or °C	
15 or 30 PSI	-1.0 to +1.0
100, 200, or 300 PSI	-5.0 to +5.0

## STAGE OUTPUT TRIM

Adjustable from -1.0 to +1.0

Default: 0.0

PRESS TO SELECT: /<Maintenance>/Output Trim

- The Stage Trim adjusts the modulation percent displayed for the stage to match the actual burner. This can be useful when the burner is far from the control. That may lead to reduction in the modulation signal.
- The Stage button scrolls through the stages.
- After adjusting the Output Trim, test the operation of the stage throughout the full range to make sure the results match your expectation.

Click the Stage button

## MODULATION SPEED

See "Modulation Speed" on page 38.

# SECURITY

- The Password is used to prevent unauthorized users from making changes to the Multi-MOD.
- Enabling up the Password is not recommended as it slows down access, makes servicing more difficult, and can disable the system if management or ownership should change.

## PASSWORD ENABLED

Yes, No

Default: No

PRESS TO SELECT: /<Maintenance>/Password

- When the Password is enabled, none of the settings can be changed without entering the Password.
- Once the Password is entered, you can make multiple changes. The Password expires 5 minutes after the last change is made.
- The default Multi-MOD Platinum Password is MM00.
- At the Login screen, you will have to enter the Password. Turn the *Adjust* knob until the desired letter is shown. Then, press the *Adjust* button to move on to the next letter.

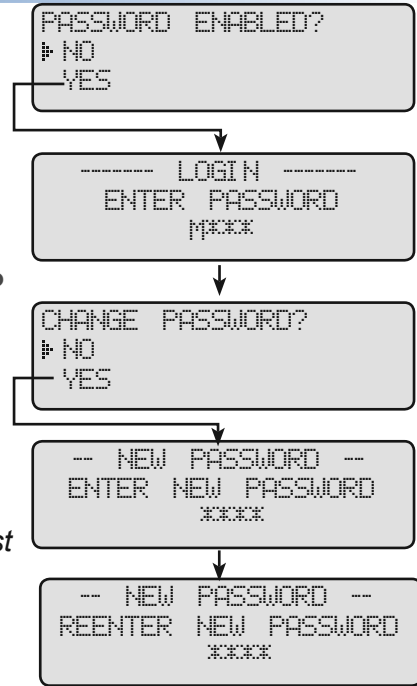

## PASSWORD CHANGE

Yes, No

Default: No

PRESS TO SELECT: /<Maintenance>/Password/Change Password?

- Follow the instructions to use the default Password, but select Yes when prompted to change the Password?
- Enter your new Password in the *New Password* screen. Turn the *Adjust* knob until the desired letter is shown. Then press the *Adjust* button to move on to the next letter. The password must consist of 4 letters.
- To confirm the password, it must be re-entered when prompted.

**⚠ ALERT**  
If the Password was enabled. Make sure to write it down and store it in a safe location known to at least one additional authorized user.

# RESET CONTROL TO FACTORY DEFAULTS

- To reset the control to factory defaults, turn off the control power. Then re-power the control back.
- During the count down, hold down the Adjust and Next buttons until the "Total Clear Started" message displays.

**⚠ WARNING**  
If total reset was performed, all saved settings including any custom control password will be lost.

TOTAL CLEAR STARTED  
Release buttons  
and  
Please wait



# TROUBLESHOOTING

## No Display, or Garbled Display

- Check the 120VAC power input to the control. Turn power to the control off and back on.
- Make sure that the Green Ground Screw is connected to a reliable Earth Ground.
- Make sure that all wiring is fed to the control through the bottom knockouts and that no voltage wiring is running behind the control board.

## SENSOR INPUTS

### Display shows Sensor OPEN or SHORT

- If the sensor reads Open, short the sensor input terminals. The display should read **Short**. If it does, then the problem is with the sensor wiring. If it doesn't, then the control may be damaged.
- If the sensor reads Short, remove the wires from the input terminals. The display should read **Open**. If it does, then the problem is with the sensor wiring. If it doesn't, the control may be damaged.

### System or Outdoor Reads an Incorrect Temperature

- Remove the wires from the input terminals. The display should change to read **Open**. If it doesn't, the Multi-MOD Platinum may be damaged.
- Otherwise, take an ohm reading across the detached sensor wires. The reading should correspond to the Temperature Sensor Chart. If the difference is within 5°F adjust the sensor trim. See "System and Outdoor Sensor Trim" on page 47. Otherwise, the sensor may be damaged.

#### Temperature Sensor Chart

TEMPERATURE		Value (in Ohms)	TEMPERATURE		Value (in Ohms)	TEMPERATURE		Value (in Ohms)
°F	°C		°F	°C		°F	°C	
OPEN		150000	30	-1	17264	90	32	3667
-30	-34	117720	35	2	14985	100	38	2914
-20	-29	82823	40	4	13040	110	43	2332
-10	-23	59076	45	7	11374	120	49	1879
0	-18	42683	50	10	9944	130	54	1524
10	-12	31215	55	13	8714	140	60	1243
20	-7	23089	60	16	7653	150	66	1021
25	-4	19939	70	21	5941	160	71	842
			80	27	4649	170	77	699
						SHORT		100

### Display shows an Incorrect Pressure

- Check the pressure range set in the System Startup. If the reading is still not correct remove the wires from input terminals S and + (A5 & A6). Check for DC voltage across the two terminals. If voltage between 5 and 36 is not present, the control may be damaged.
- Connect the black sensor wire to terminal + (A6). Put an amp meter in series by connecting the meter's (-) to the sensor's detached red wire, and connect the meter's (+) side to the S (A5) input terminal. The mA reading should correspond to the Pressure Sensor Chart. If it doesn't, the sensor may be damaged.

#### Pressure Sensor Chart

INPUT (in mA)	0-30 Range (in PSI)	0-100 Range (in PSI)	0-200 Range (in PSI)	0-300 Range (in PSI)	INPUT (in mA)	0-30 Range (in PSI)	0-100 Range (in PSI)	0-200 Range (in PSI)	0-300 Range (in PSI)
2	Open				13.6	18	60	120	180
4	0	0	0	0	16.8	24	80	160	240
7.2	6	20	40	60	20	30	100	100	300
10.4	12	40	80	120	22	Short			

---

## CONTROL OPERATION

### No Heat

- **Outdoor Cutoff** - If the Outdoor sensor reading was higher than the Outdoor Cutoff temperature, the control might not bring any stage on. See "Outdoor Cutoff Temperature" on page 32.
- **Prove** - Even though the system relay may be energized, the control will not energize any stages unless the Prove is shorted. See "Display Messages" on page 29.
- **Shutdown** - The Multi-MOD Platinum modulates the stages to off when the Shutdown terminals are shorted. See "Display Messages" on page 24. Also, see "Shutdown Wiring" on page 18.
- **Sensor Fault** - When the Sensor Fault is set to Shutdown, a System sensor fault will de-activate all stages outputs. See "Sensor Fault" on page 29.

### Too Much Heat

Check if the control has any of the following:

- **Reset Ratio and Offset** - If excessive heat occurs only under certain weather conditions, adjust the Reset Ratio. See "Reset Ratio" on page 33. If excessive heat occurs year round, reduce the Offset. See "Target Offset" on page 33.
- **Boiler Mode Settings** - The Multi-MOD Platinum only modulate boilers their Mode is set to Auto or Standby. Check if any boiler stage is set to Manual or On. See "Mode" on page 39.
- **Control Settings** - The Last-Stage-Hold allows only the lead boiler to stay on longer. If the setting is too high, the system can over heat. Reduce the Last-Stage-Hold setting. See "Last-Stage-Hold" on page 37.
- **DHW Call** - On a DHW call, the system target will change to the DHW Set Point. If the DHW Call lasted for a long time, the building may overheat if DHW No Priority or DHW Using System were selected. See "Prove/DHW Mode" on page 28 and "DHW Set Point" on page 29.

### Too Little Heat

Check if the control has any of the following:

- **Reset Ratio and Offset** - If reduced heat occurs only under certain weather conditions, adjust the Reset Ratio. See "Reset Ratio" on page 33. If reduced heat occurs year round, increase the Offset. See "Target Offset" on page 33.
- **Setback** - If reduced heat occurs only during specific hours, check the Setback value and the source of the setback signal. Either reduce the Setback setting or change the Schedule. See "Setback" on page 35. Also, see "Schedules" on page 42.

### Internet Operation

#### Values on the Web do not Change

- **Internet connection to the control** - First check the ICMS Live Session "Last Values Update" Date and Time. It must be current. If not, the control internet connection is not functioning. If using a router, check for Internet service using a computer. If using a cable modem, power down both the control and the modem. Then power the control back on and wait for one minute before power the modem back on. Wait for the message "ACK RECEIVED" to display.

# SPECIFICATIONS

Voltage Input:	120 VAC 60 Hz
Power Consumption:	.30 VA Max
Operating Temperature:	20°F/-7°C to 120°F/49°C
Weight:	14 pounds

## MULTI-MOD PLATINUM SPECIFICATIONS

Output Relays:	(5) N.O. S.P.S.T
Sensor Types:	Temperature, Reset, or Pressure
Modulating Output Types:	Current (4-20mA)/Voltage (0-5V, 0-10V, 1-5V, 2-10V)/135Ω
Output Relay Ratings:	(5) 1 Amp Inductive, 6Amp resistive at 120 VAC 60 Hz (1/8HP)
Ignition Point %:	1 to 50%
Modulation Start Point %:	0 to 100%
Modulation Modes:	Normal or Parallel
Operation Modes:	Normal or Process
Heat/Cool Modes:	Heating or Cooling
Display:	Alphanumeric (4 rows x 20 char. each)
LED:	(1) System Output relay, (4) Boiler Output relays
Standard Temperature Sensor Range:	-35°F/-37°C to 250°F/121°C
4-20mA Temperature Sensor Ranges:	Must be Configured by Heat-Timer
Pressure Transducer Ranges:	0-15psi, 0-30psi, 0-100psi, 0-200psi, 0-300psi
Outdoor Cutoff Range:	20°F/-7°C to 100°F/38°C, ON and OFF
Reset Ratio Range (Reset Only):	(1.00 : 4.00) to (4.00 : 1.00) (Outdoor : System Water)
Offset Adjustment (Reset Only):	-40°F/-22°C to + 40°F/+22°C
Minimum Water Temperature (Reset Only):	70°F/21°C to 170°F/77°C
Maximum Water Temperature (Reset Only):	90°F/32°C to 240°F/115°C
Set Point Ranges:	See "Sensor Type Table" on page 26.
DHW Set Point Temperature Range:	140°F/60°C to 200°F/93°C
System Run-On:	0 to 360 minutes
Purge Delay:	0.0 to 10.0 minutes
Lag Delay:	0 to 60 minutes
Last-Stage-Hold:	See "Sensor Type Table" on page 26.
Setback:	See "Sensor Type Table" on page 26.
Lead Stage Rotation:	Time ( 1 to 999 Hours (41 days)), Manual, Last-On
Stage Modes:	Auto, Manual (0% - 100%), Standby, On, Off
Standby Time:	1 to 60 minutes
Power Backup:	Lithium coin battery, 100 days (Maintains Clock in power outages).
External Inputs:	Shutdown Input, Setback Input, and Prove Input (Dry-contacts Only) External Set Point input (4-20mA)
Max add-On Extension Modules:	up to two Extension Modules using RS485
Lockout Inputs:	4 Lockout inputs
Remote Communication Options:	Internet, BACnet IP, BACnet MSTP, MODBUS

## EXTENSION MODULE SPECIFICATIONS

Modulating Output Types:	Current (4-20mA)/Voltage (0-5V, 0-10V, 1-5V, 2-10V)/135Ω
Output Relay Ratings:	(8) 1 Amp Inductive, 6Amp resistive at 120 VAC 60 Hz (1/8HP)
LED:	(8) Boiler Output relays, (1) Power, (1) Communication
Lockout Inputs:	(8) Lockout inputs
Extension number:	determined by Extension Dip Switch settings
Connection to Control:	All cables provided with Extension

# WIRING DIAGRAMS

## WIRING 4 MODULATING HYDRONIC BOILERS WITH SYSTEM PUMP OUTPUT AND LOCKOUTS, SHUTDOWN, AND DHW CALL INPUTS

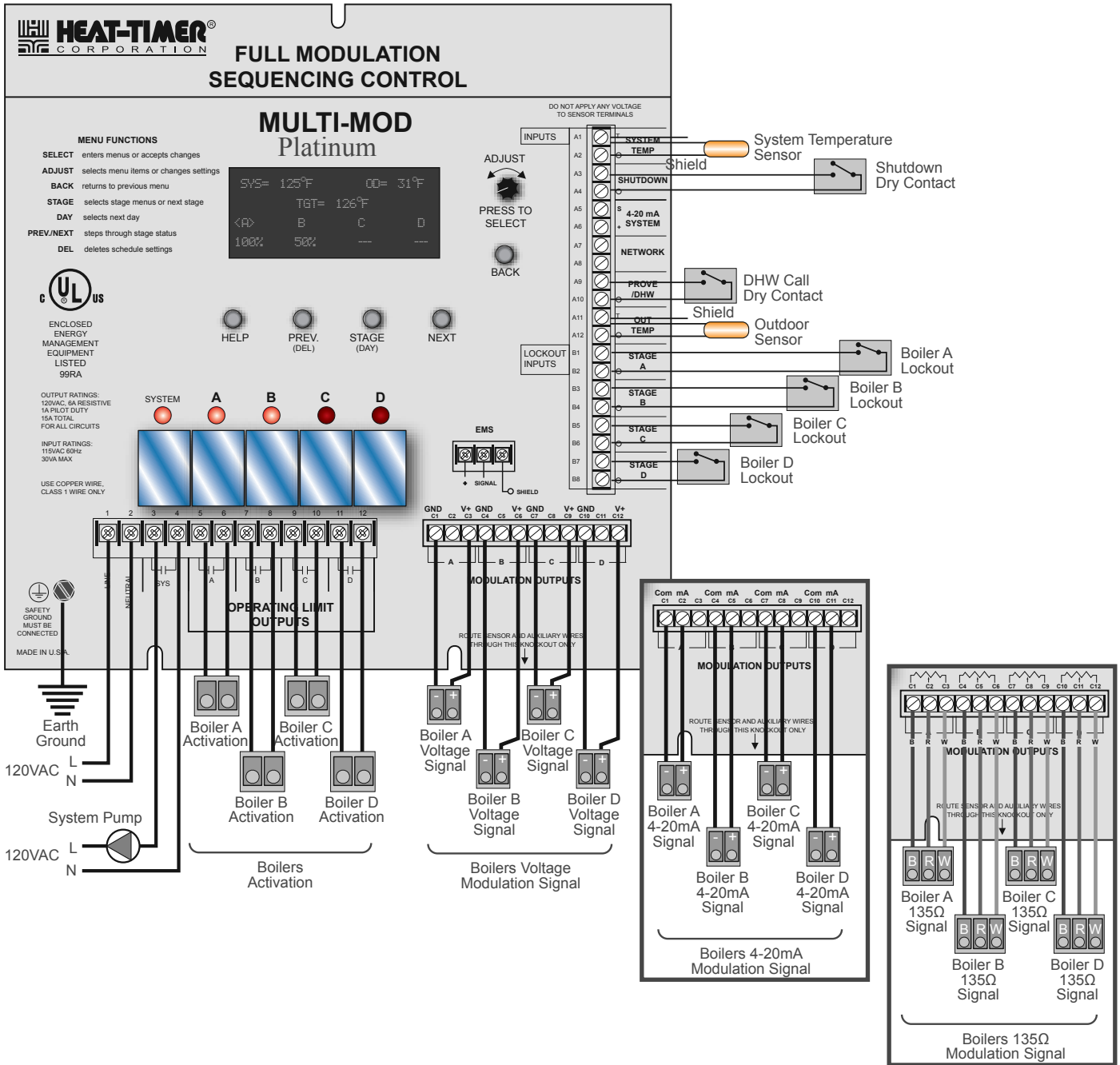

### Multi-MOD Platinum Startup Settings:

- Sensor Type = °F, °C, Reset °F, or Reset °C
- Sys Temp Sensor Type = Standard
- Prove/DHW = Any DHW Priority option

**ALERT**  
 Due to the uniqueness of each installation, Heat-Timer Corp. is not responsible for any installation that is based on any electrical or piping diagram generated. The provided illustrations are to demonstrate the control's operating concept only.

HT# 059299-00 A

The Multi-MOD Platinum is set to control four modulating hydronic boilers and the primary loop system pump. Each boiler is connected to the control's modulation signal and activation signal. Each boiler lockout circuit is wired to the Multi-MOD Platinum's Lockout inputs. In addition, the Multi-MOD Platinum is connected to the DHW call and Shutdown inputs.

# WIRING 4 MODULATING HYDRONIC BOILERS WITH SYSTEM PUMP OUTPUT AND LOCKOUTS, SHUTDOWN, AND PROVE INPUTS

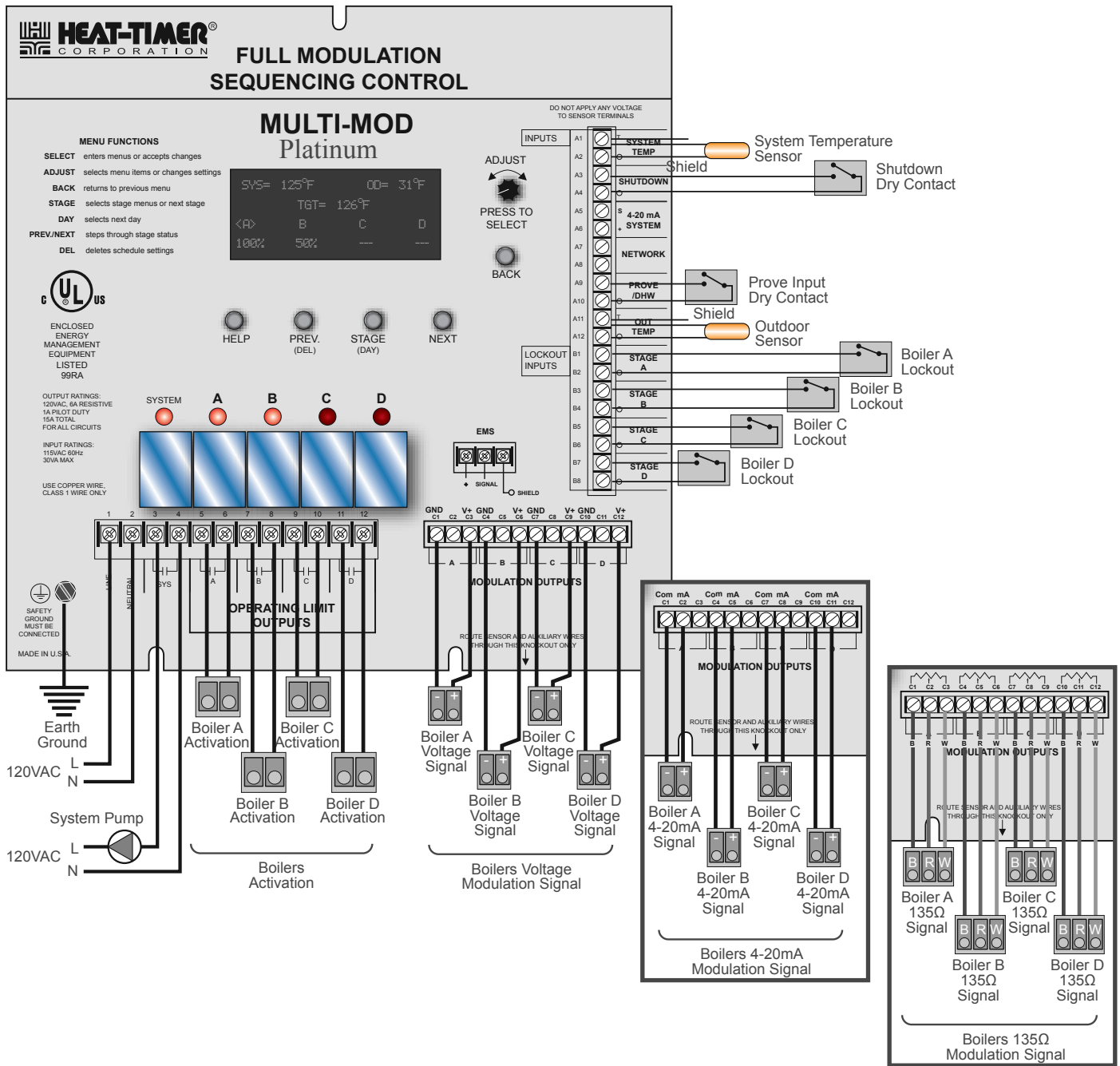

### Multi-MOD Platinum Startup Settings:

- Sensor Type = °F, °C, Reset °F, or Reset °C
- Sys Temp Sensor Type = Standard
- Prove/DHW = Prove

**⚠ ALERT**

Due to the uniqueness of each installation, Heat-Timer Corp. is not responsible for any installation that is based on any electrical or piping diagram generated. The provided illustrations are to demonstrate the control's operating concept only.

The Multi-MOD Platinum is set to control four modulating hydronic boilers and the primary loop system pump. Each boiler is connected to the control's modulation signal and activation signal. Each boiler lockout circuit is wired to the Multi-MOD Platinum's Lockout inputs. In addition, the Multi-MOD Platinum is connected to the Prove and Shutdown inputs.

# WIRING 4 MODULATING HYDRONIC BOILERS WITH SYSTEM PUMP OUTPUT AND LOCKOUTS, SHUTDOWN, AND PROVE INPUTS

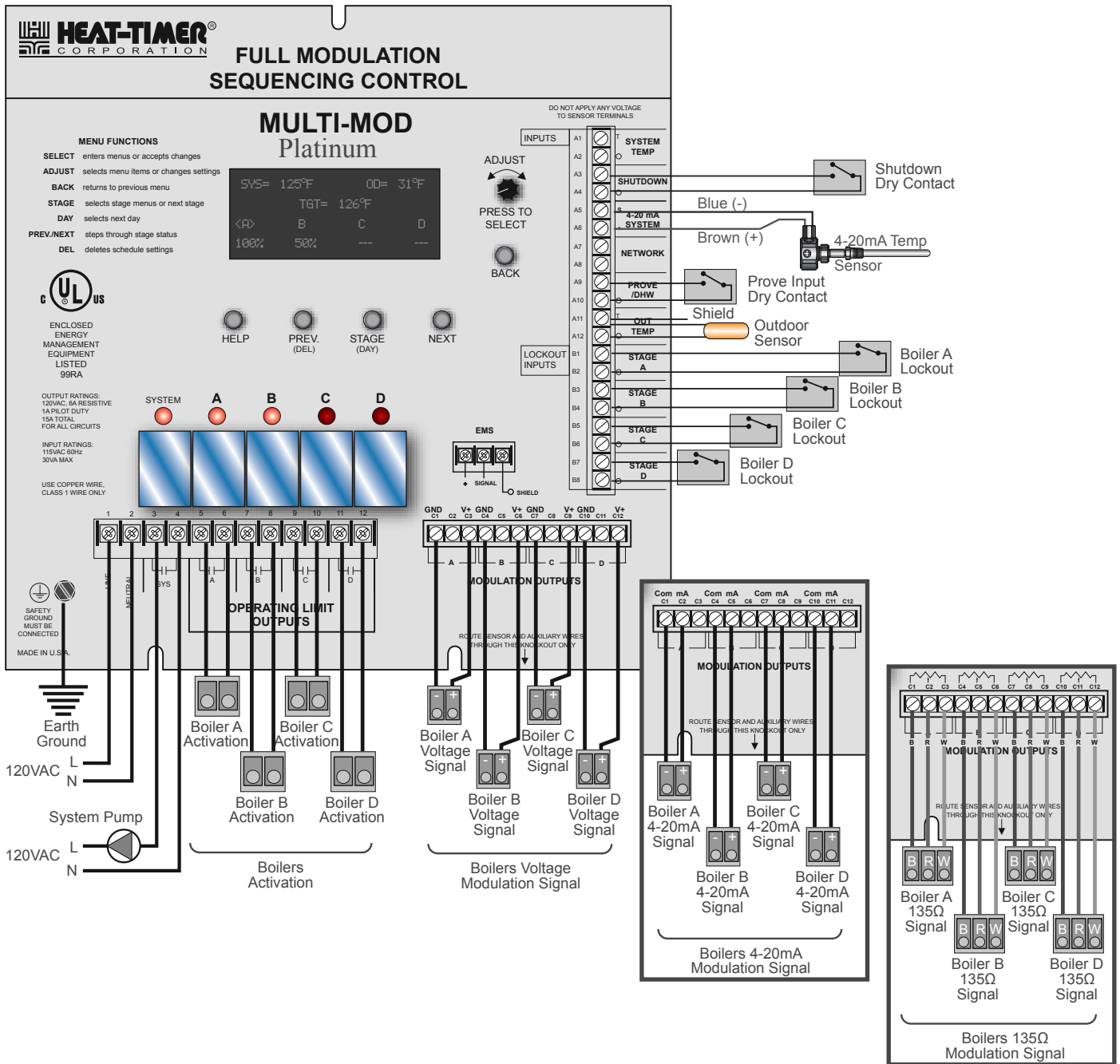

### Multi-MOD Platinum Startup Settings:

- Sensor Type = °F, °C, Reset °F, or Reset °C
- Sys Temp Sensor Type = 4-20mA
- Prove/DHW = Prove

**⚠ ALERT**

Due to the uniqueness of each installation, Heat-Timer Corp. is not responsible for any installation that is based on any electrical or piping diagram generated. The provided illustrations are to demonstrate the control's operating concept only.

The Multi-MOD Platinum is set to control four modulating hydronic boilers and the primary loop system pump. Each boiler is connected to the control's modulation signal and activation signal. Each boiler lockout circuit is wired to the Multi-MOD Platinum's Lockout inputs. In addition, the Multi-MOD Platinum is connected to the Prove, 4-20mA temp sensor, and Shutdown inputs.

HT# 059299-00 A

# WIRING 4 MODULATING HYDRONIC BOILERS AND THEIR PUMPS OUTPUT AND LOCKOUTS, SHUTDOWN, AND PROVE INPUTS

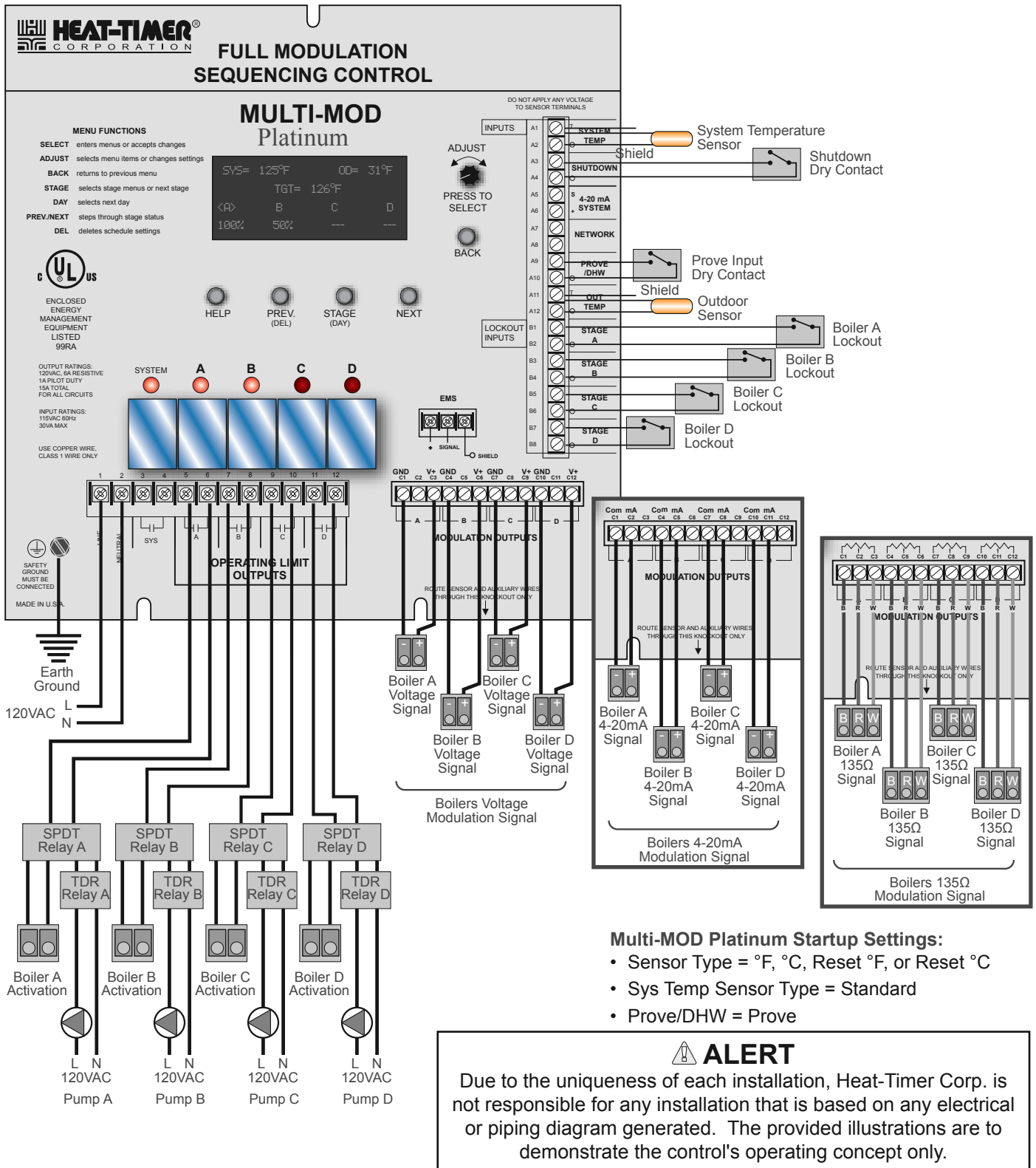

The Multi-MOD Platinum is set to control four modulating hydronic boilers and their pumps. Each boiler is connected to the control's modulation signal and activation signal. Each boiler lockout circuit is wired to the Multi-MOD Platinum's Lockout inputs. In addition, the Multi-MOD Platinum is connected to the Prove and Shutdown inputs.

HT# 059299-00 A

# WIRING 4 MODULATING STEAM BOILERS OUTPUTS AND LOCKOUTS, SHUTDOWN, AND PROVE INPUTS

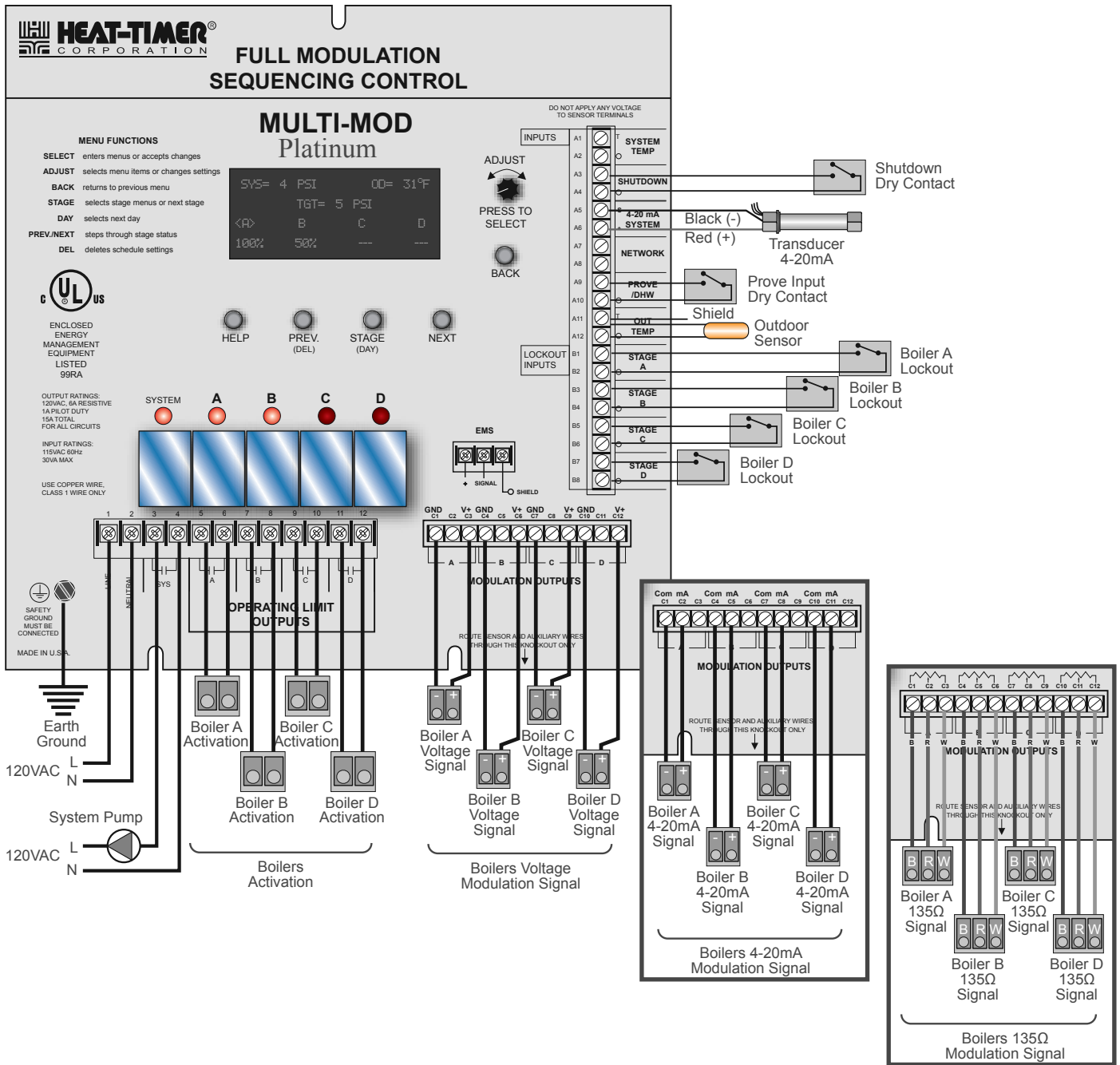

**ALERT**

Due to the uniqueness of each installation, Heat-Timer Corp. is not responsible for any installation that is based on any electrical or piping diagram generated. The provided illustrations are to demonstrate the control's operating concept only.

**Multi-MOD Platinum Startup Settings:**

- Sensor Type = Pressure
- Sys Temp Sensor Type = Standard
- Prove/DHW = Prove

The Multi-MOD Platinum is set to control four modulating steam boilers. Each boiler is connected to the control's modulation signal and activation signal. Each boiler lockout circuit is wired to the Multi-MOD Platinum's Lockout inputs. In addition, the Multi-MOD Platinum is connected to the Prove and Shutdown inputs.

HT# 059299-00 A



# WIRING 8 MODULATING HYDRONIC BOILERS OUTPUTS AND LOCKOUTS, SHUTDOWN, AND PROVE INPUTS

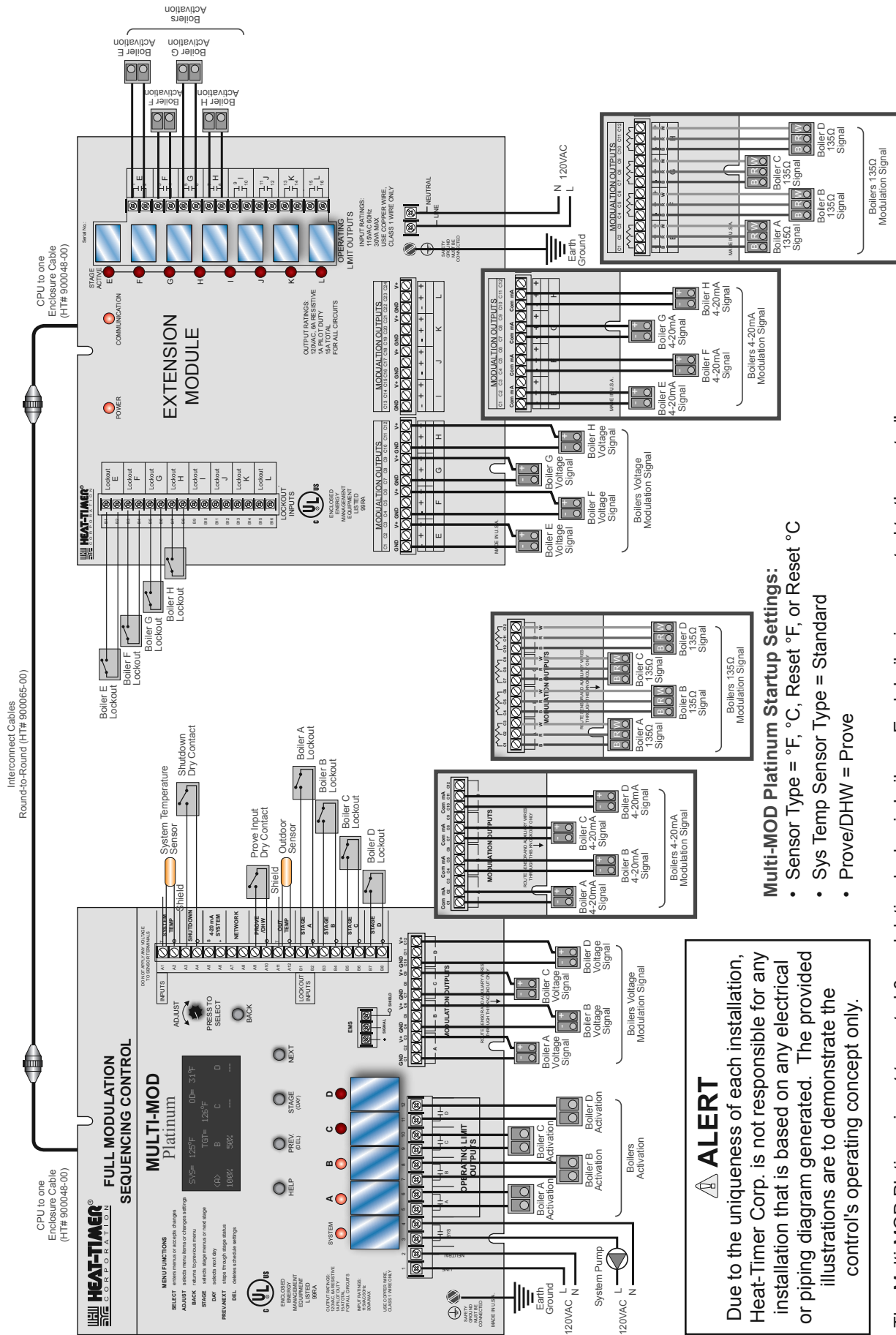

**ALERT**

Due to the uniqueness of each installation, Heat-Timer Corp. is not responsible for any installation that is based on any electrical or piping diagram generated. The provided illustrations are to demonstrate the control's operating concept only.

### Multi-MOD Platinum Startup Settings:

- Sensor Type = °F, °C, Reset °F, or Reset °C
- Sys Temp Sensor Type = Standard
- Prove/DHW = Prove

The Multi-MOD Platinum is set to control 8 modulating hydronic boilers. Each boiler is connected to the control's modulation signal and activation signal. The boiler lockout circuit is wired to the Multi-MOD Platinum's Lockout inputs. In addition, the Multi-MOD Platinum is connected to the Prove and Shutdown inputs.

# WARRANTY

**WARRANTIES AND LIMITATIONS OF LIABILITY AND DAMAGE:** Heat-Timer Corporation warrants that it will replace, or at its option, repair any Heat-Timer Corporation manufactured product or part thereof which is found to be defective in material workmanship within one year from the date of installation only if the warranty registration has been properly filled out and returned within 30 days of the date of installation. Damages to the product or part thereof due to misuse, abuse, improper installation by others or caused by power failure, power surges, fire, flood or lightning are not covered by this warranty. Any service, repairs, modifications or alterations to the product not expressly authorized by Heat-Timer Corporation will invalidate the warranty. Batteries are not included in this warranty. This warranty applies only to the original user and is not assignable or transferable. Heat-Timer Corporation shall not be responsible for any maladjustments of any control installed by Heat-Timer Corporation. It is the users responsibility to adjust the settings of the control to provide the proper amount of heat or cooling required in the premises and for proper operation of the heating or cooling system. Heat-Timer Corporation shall not be required to make any changes to any building systems, including but not limited to the heating system, boilers or electrical power system, that is required for proper operation of any controls or other equipment installed by Heat-Timer Corporation or any contractor. Third Party products and services are not covered by this Heat-Timer Corporation warranty and Heat-Timer Corporation makes no representations or warranties on behalf of such third parties. Any warranty on such products or services is from the supplier, manufacturer, or licensor of the product or service. See separate Terms and Conditions of Internet Control Management System (“ICMS”) services, including warranties and limitations of liability and damages, for ICMS services.

**THE FOREGOING IS IN LIEU OF ALL OTHER WARRANTIES, EXPRESS OR IMPLIED AND HEAT-TIMER CORPORATION SPECIFICALLY DISCLAIMS ANY AND ALL WARRANTIES OF MERCHANTABILITY FOR A PARTICULAR PURPOSE. UNDER NO CIRCUMSTANCES SHALL HEAT-TIMER CORPORATION, ITS AUTHORIZED REPRESENTATIVES, AFFILIATED OR SUBSIDIARY COMPANIES BE LIABLE FOR SPECIAL, CONSEQUENTIAL OR INCIDENTAL DAMAGES, EXCEPT AS SPECIFICALLY STATED IN THESE TERMS AND CONDITIONS OF SALE. THE SOLE REMEDY WITH RESPECT TO ANY PRODUCT OR PART SOLD OR INSTALLED BY HEAT-TIMER CORPORATION SHALL BE LIMITED TO THE RIGHT TO REPLACEMENT OR REPAIR F.O.B. FAIRFIELD, NJ. HEAT-TIMER CORPORATION SHALL NOT BE LIABLE OR RESPONSIBLE FOR LOSS OR DAMAGE OF ANY KIND RESULTING FROM DELAY OR INABILITY TO DELIVER FOR ANY REASON, INCLUDING BUT NOT LIMITED TO FIRE, FLOOD, LIGHTNING, POWER FAILURE OR SURGES, UNAVAILABILITY OF PARTS, STRIKES OR LABOR DISPUTES, ACCIDENTS AND ACTS OF CIVIL OR MILITARY AUTHORITIES.**

REV. 03122010





20 New Dutch Lane, Fairfield, NJ 07004  
Ph: (973) 575-4004 • Fax: (973) 575-4052  
<http://www.heat-timer.com>