

HEAT-TIMER[®] CORPORATION

INSTALLATION AND OPERATION INSTRUCTIONS

Mini-MOD-CNC & Extension CONDENSING / NON-CONDENSING CONTROL

FOR HYDRONIC HEATING SYSTEMS

PATENT PENDING

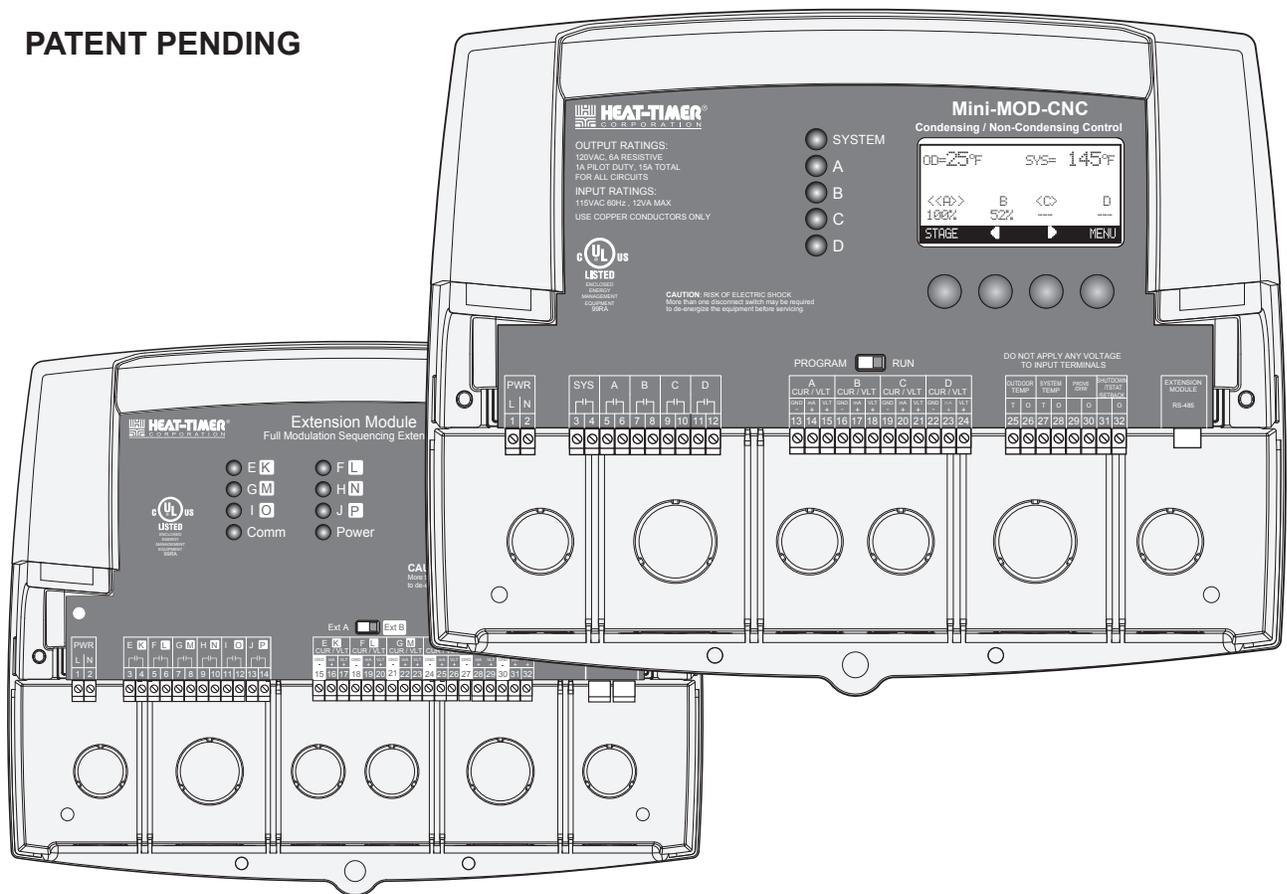

⚠ WARNING

The Mini-MOD-CNC is strictly an operating control. It CANNOT be used as a limit control. All boilers must have all safety and limit controls required by code. It is the responsibility of the installer to verify that all the safety and limits are working properly.

This control must be installed by a licensed electrician.

Contents

Mini-MOD-CNC Overview	3	Setting the Control to Factory Defaults.	20
Mini-MOD-CNC Layout	4	Operating Menu Sequence	21
Mini-Extension Layout	5	Operating Settings	22
Features	6	Program Change Switch Setting	22
Outdoor Reset Concept	7	Season	22
Reset Ratio/Outdoor Reset	7	Reset Ratio	22
Make Sure You Have the Right Control	8	Offset	22
Initial Setup	8	Outdoor Cutoff Temperature	23
Selecting the System Features.	8	Minimum Water Temp	23
Installation	9	Maximum Water Temp	23
Mounting the Enclosure	9	System Settings	24
Install the Sensors	10	Setback	24
System Sensor (HSS) Installation	10	Purge Delay	24
Outdoor Sensor Installation	10	System Run-On	24
Wiring	11	Lead Boiler Rotation	25
Wiring the Power.	11	Standby Time	25
Wiring the Sensors	11	Last Stage Hold	25
Wiring the Shutdown, Tstat, or Setback	11	Lead Stages	25
Wiring the Prove	12	Operating Modulating Boiler Settings	26
Wiring the Domestic Hot Water (DHW) Call	12	Gain.	26
Wiring the System Output	12	Lag Delay	26
Wiring the Boilers	13	Soft-Off Delay	26
Wiring Multi-Stage Boiler Outputs	13	Operating Staging Boiler Settings	27
Wiring to Modulating Output	13	Reaction Time	27
Connecting to the Mini-Extension Panels	14	Minimum Runtime	27
Connecting to the 4-20mA EMS Interface	14	Day / Night Schedule.	28
Startup Menu Sequence	15	Set Time.	28
Startup Settings	16	History	28
Program Change Switch Setting	16	Maintenance	28
Startup Sequence	16	System & Outdoor Sensor Trim	29
Sensor Type	16	Output Modulation Trim.	29
Switch Set Point	16	Configuration	29
Switch Differential	17	Display	30
Switch Delay.	17	Boiler Status.	30
Heavy Load Sequence 2nd Group	17	Display Sequencing Boiler Status	30
Condensing Boiler Type	17	Display Messages	30
Condensing and Non-Condensing Boiler Number	17	Boiler Stage Settings.	31
Modulating Boiler Settings	18	Mode	31
Modulating Output Type	18	Ignition %	32
Modulating Mode.	18	Modulation Start %	32
Sequencing Boiler Settings	19	Copy Settings - Boiler A Only	32
Sequencing Output Type	19	Troubleshooting.	33
Staging Mode	19	Direct Heating Piping Diagram	34
Prove/Domestic Hot Water (DHW) Priority	19	Direct Heating Wiring Diagram	35
Domestic Hot Water Set Point	19	Warranty	36
Shutdown/Tstat/Setback Mode	19	Index	37
Boost Mode	20	Specifications	40
Sensor Fault.	20		

MINI-MOD-CNC OVERVIEW

In response to new advancement in condensing boiler design and size, many applications utilize multiple condensing boilers in addition to the non-condensing boilers. That triggered Heat-Timer's patent design of the Mini-MOD-CNC . It is intended to manage the two groups of boilers to maximize system efficiency at the lowest operating cost while maintaining the desired comfort. The Mini-MOD-CNC operates each group based on the Target temperature switching set point.

Depending on the actual Target Temperature, the Mini-MOD-CNC will determine which group of boilers will be the lead and which group will be the lag group. The Condensing Group of boilers will be the Lead group when the Target Temperature is below the Switching Set Point. However, when the Target Temperature rises above the Switching Set Point, the Non-Condensing Boiler Group will be the lead group and the Condensing Group will be the lag group.

Basically, the Mini-MOD-CNC will allow the condensing group of boilers to operate as long as the Target Temperature is below the Switching Set Point. See "Switch Set Point" on page 16. During that period, if additional output boilers are needed, the Mini-MOD-CNC will energize the non-condensing boilers to meet the load. See "Heavy Load Sequence 2nd Group" on page 17. When less output is required the Mini-MOD-CNC will de-energize the non-condensing boilers prior to de-energizing the condensing boilers.

SWITCH MODE = Target Temperature

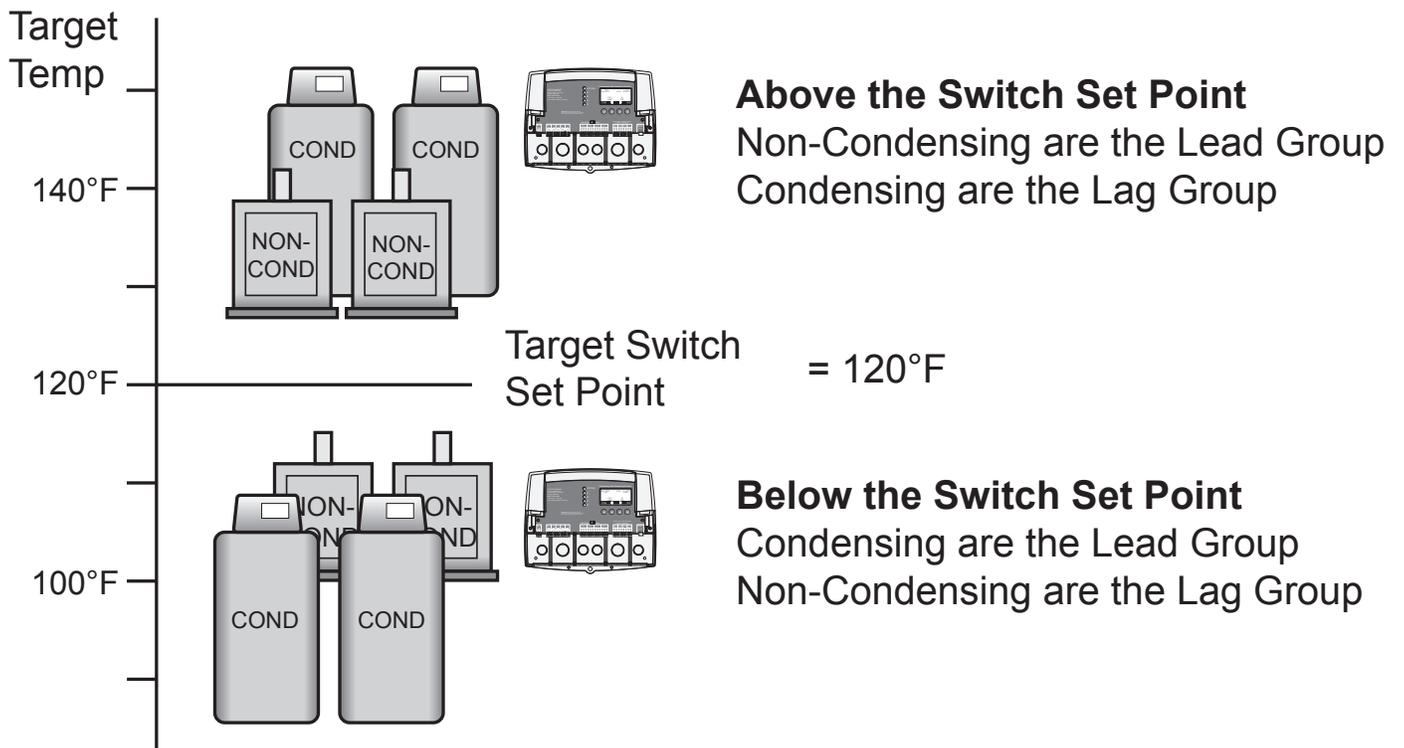

MINI-MOD-CNC LAYOUT

Program Switch to restrict access to function changes. This switch is covered with the Wiring Enclosure.

The digital display shows the System and Outdoor temperatures, the lead stage and lead group <<in brackets>>, and the status of each stage. To view and adjust settings, press the appropriate buttons.

LED indicates the associated relay status.

Button functions are presented on Bottom Row of display.

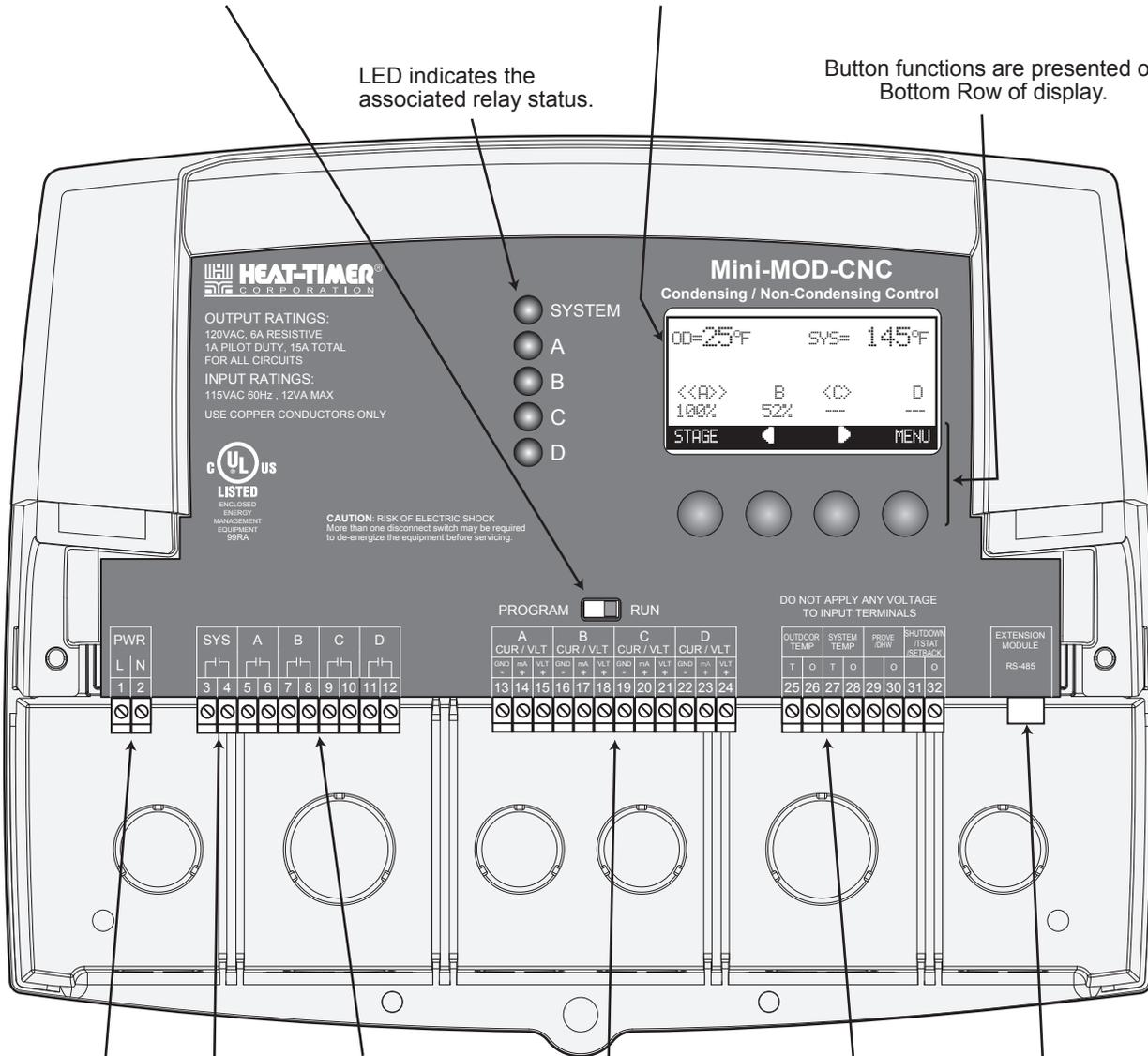

120VAC Power

Four N.O. Boiler startup relay outputs. Each is wired in series with each boiler's limit circuit.

When connecting Outdoor and System Sensors, no Polarity is observed. Prove terminals must be connected for the Mini-Mod-CNC to operate the boilers.

System Output controls pumps, valves, or other system components.

Four modulation outputs can be 0-5V, 0-10V, 1-5V, 2-10V, or 4-20ma. Go to Startup Menu to determine the type of output for each stage.

Connect Extension panels to add additional stages using a phone style cable (cable provided with Mini-Extension).

MINI-EXTENSION LAYOUT

LED indicates the associated relay status.

Extension Selection Switch to determine Stage letters and LED colors.
 Ext-A Stages E - J and all LEDs are Green
 Ext-B Stages K - P and all LEDs are Red
 This switch is covered with the Wiring Enclosure.

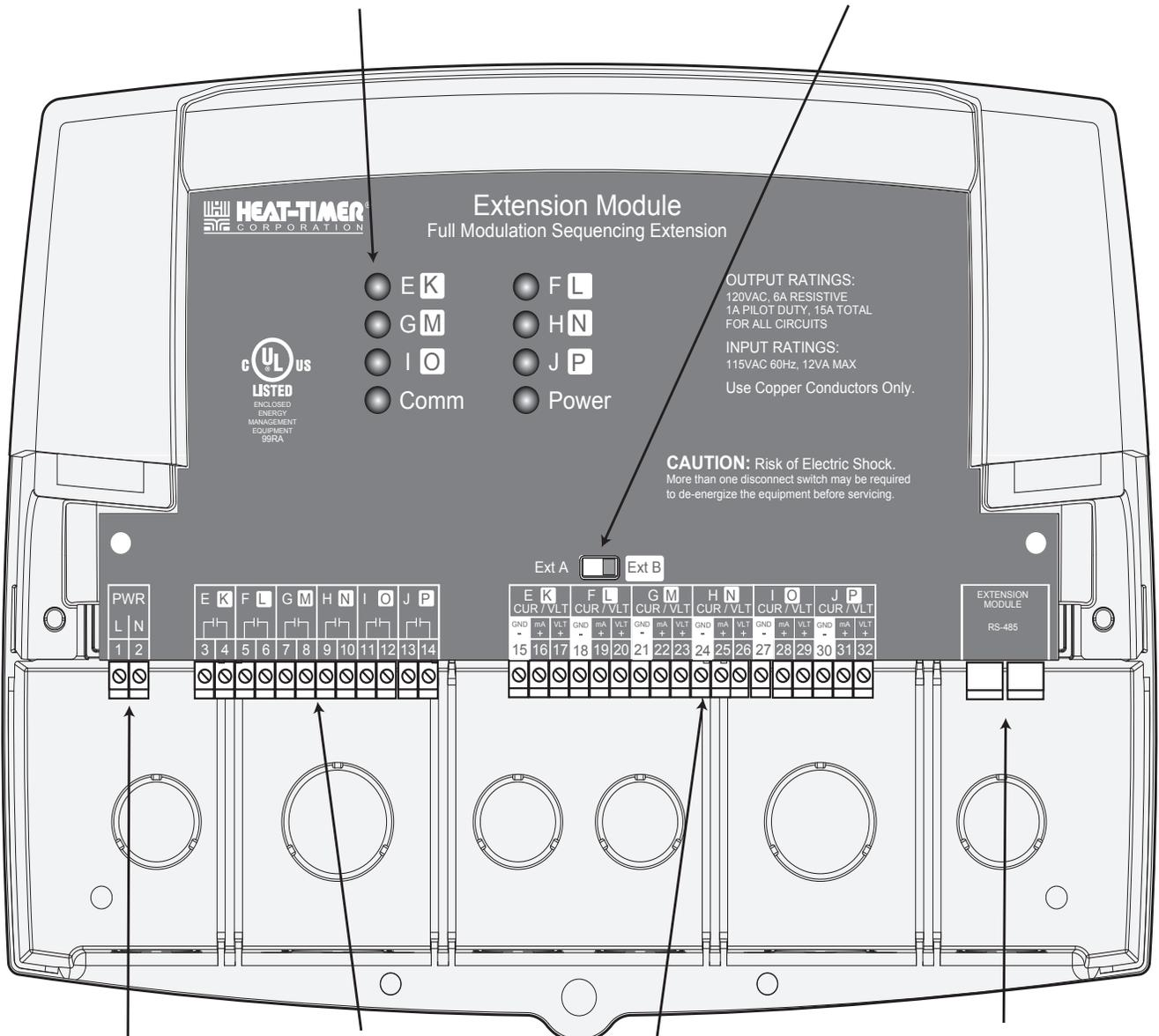

OUTPUT RATINGS:
 120VAC, 6A RESISTIVE
 1A PILOT DUTY, 15A TOTAL
 FOR ALL CIRCUITS
 INPUT RATINGS:
 115VAC 60Hz, 12VA MAX
 Use Copper Conductors Only.

CAUTION: Risk of Electric Shock.
 More than one disconnect switch may be required
 to de-energize the equipment before servicing.

120VAC Power

Six N.O. Boiler startup relay outputs. Each is wired in series with the boiler's limit circuit.

Six modulating outputs can be 0-5V, 0-10V, 1-5V, 2-10V, or 4-20ma. Go to Mini-MOD or Mini-MOD-CNC Startup Menu to determine the type of output for each stage.

Connect to Mini-MOD or Mini-MOD-CNC and additional Extension panels to add additional stages using phone style cable (cable provided with Mini-Extension).

FEATURES

CONDENSING AND NON-CONDENSING BOILERS CAN BE MODULATING OR MULTI-STAGE.

The Mini-MOD-CNC can operate both modulating and staging boilers. Just specify each of the Condensing and Non-Condensing Boiler Group type and the Mini-MOD-CNC will activate the groups based on an adjustable set of criteria.

PID TYPE LOGIC

The Mini-MOD-CNC's control algorithms allow it to look at the rate of change in the system. If the system temperature is changing quickly, the Mini-MOD-CNC will react quickly to adjust the modulating stages' output. If the system temperature changes slowly, the Mini-MOD-CNC will make slow and gradual output adjustments. Therefore, the Mini-MOD-CNC adapts to specific system requirements and minimizes fluctuations around the set point.

CONTROLS 0-5 V, 0-10 V, 1-5V, 2-10V, OR 4-20MA MODULATING BURNERS

Whenever any of the Condensing or Non-Condensing Boiler Group type is set to Modulating, the Mini-MOD-CNC will accurately control the output from 0 to 100% of modulation for each of these different types of motors. Moreover, a single Mini-MOD-CNC can control multiple modulating burners each with a different modulating signal.

CONTROLS ON/OFF, 2-STAGE, 3-STAGE, OR 4-STAGE BURNERS

Whenever one of the Condensing or Non-Condensing Boiler Group Type is set to Staging, the Mini-MOD-CNC will accurately sequence the stages using a PID logic. The sequencing group will have a set of adjustable parameters to help achieve better operation.

DIGITAL DISPLAY OF ALL SYSTEM SETTINGS

The Mini-MOD-CNC's alphanumeric digital display names each system parameter in simple English and shows its precise value. The easy to follow menu system allows users to quickly make changes to any system setting without having to learn any specialized codes or keyboard commands.

AUTOMATIC ROTATION AMONG STAGES

Rotating the lead stage of each group promotes even wear. The Mini-MOD-CNC has three modes of rotation: Manual, Last On, or Time. The Time rotates the lead stage every selected time period from every hour to every 60 days.

OUTDOOR RESET

The Mini-MOD-CNC has a hydronic outdoor temperature reset function. This allows the Mini-MOD-CNC to change the set point based on outdoor temperature. Furthermore, additional settings have been added to fine tune this operation, like Offset, Minimum, and Maximum Water Temperature and night setback schedule.

SYSTEM OUTPUT

This output can be used to activate a system pump, combustion air damper, or perform any other function that is required when any stage is active. It will energize whenever the outdoor temperature is below the Outdoor Cutoff setting. A System Prove input checks the status of components activated by the System output before stages can be activated.

NORMAL OR PARALLEL MODULATION

The Mini-MOD-CNC can stage modulating boilers as needed. In Normal Modulation, it will allow the modulation to increase on the lead boiler until it reaches its modulation start point adjustment. Then, the Mini-MOD-CNC will start the next boiler and so on. Moreover, the Mini-MOD-CNC allows for a parallel mode that can modulate several boilers together as a one large boiler. This mode is useful when used with condensing boilers as they run more efficient at lower modulation. Thus, it is better to run several boilers at lower modulation than to run a single boiler at full fire.

ADD UP TO 16 BOILER STAGES (OPTIONAL)

As a stand-alone, the Mini-MOD-CNC is designed to control four stages. However, it has the capability of expanding its control to two extension panels (HT# 926712-00) each with six boiler stages. Thus, the Mini-MOD-CNC can control a total of up to 16 boiler stages.

OUTDOOR RESET CONCEPT

The Mini-MOD-CNC has multiple operating modes that satisfy most hydronic systems. It changes the System Set Point based on outdoor temperature (Outdoor Reset). The Mini-MOD-CNC varies the temperature of the circulating heating water in response to changes in the outdoor temperature. The heating water temperature is controlled through the modulation or sequencing of the stages.

The Mini-MOD-CNC also controls the system circulating pump with an adjustable Outdoor Cutoff. When the outdoor temperature is above the Outdoor Cutoff, the pump is off and no heating water is circulated through the system. When the outdoor temperature drops below the Outdoor Cutoff, the system pump relay is activated and the heating water circulates through the system. The temperature of the heating water is controlled by the Reset Ratio, Water Offset, and changes with Outdoor temperature.

RESET RATIO/OUTDOOR RESET

When a building is being heated, heat escapes through the walls, doors, and windows to the colder outside air. The colder the outside temperature, the more heat escapes. If you can input heat into the building at the same rate that it is lost out of the building, then the building temperatures will remain constant. The Reset Ratio is an adjustment that lets you achieve this equilibrium between heat input and heat loss.

The starting point for most systems is the 1.00 (OD):1.00 (SYS) (Outdoor Temperature : Heating Water Temperature) ratio. This means that for every degree the outdoor temperature drops, the temperature of the heating water will increase one degree. The starting point of the curve is adjustable, but comes factory selected at 70°F Outdoor Temp. and 100°F Water Temp. For example with a 1.00 (OD):1.00 (SYS) ratio, if the outdoor temperature is 50°F, this means the temperature has fallen 20° from the starting point of 70°F. Therefore, the heating water temperature will increase 20° to 120°F.

Each building has different heat loss characteristics. A very well insulated building will not lose much heat to the outside air, and may need a Reset Ratio of 2.00 (OD):1.00 (SYS) (Outdoor:Water). This means the outdoor temperature would have to drop 2 degrees to increase the water temperature 1 degree. On the other hand, a poorly insulated building with insufficient radiation may need a Reset Ratio of 1.00 (OD):2.00 (SYS). This means that for each degree the outdoor temperature dropped the water temperature will increase 2 degrees. The Mini-MOD-CNC has a full range of Reset Ratios to match any buildings heat loss characteristics.

A heating curve that relies not only on Outdoor temperature but also on the type of radiation will improve heat comfort. The following are suggested initial settings for different types of radiation based on average building insulation and heat loss. The contractor can fine tune these adjustments based on the specific building need.

Type of Radiation in Building	Reset Ratio	Offset
Radiators (Steel & Cast Iron)	1.00 (OD) : 1.00 (SYS)	0°F
Baseboard (Finned copper tube& Cast Iron)	1.00 (OD) : 1.00 (SYS)	0°F
Radiant (High Mass/Concrete)	4.00 (OD) : 1.00 (SYS)	-10°F
Radiant (Low Mass/Joists)	2.00 (OD) : 1.00 (SYS)	-10°F
Fan Coils & Air Handlers	1.00 (OD) : 1.00 (SYS)	20°F

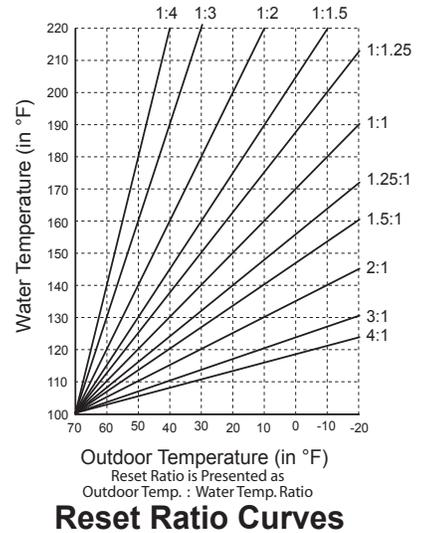

With a 0° Offset, the Reset curves begin at 100° Water Temperature.

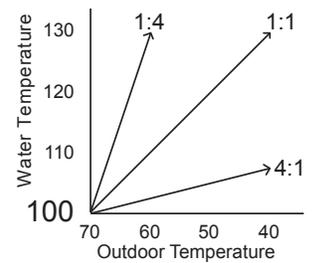

With a -20° Offset, the Reset curves begin at 80° Water Temperature.

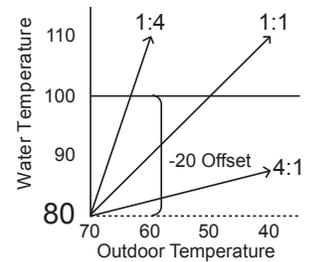

With a +20° Offset, the Reset curves begin at 120° Water Temperature.

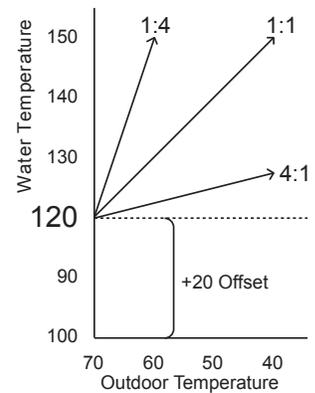

MAKE SURE YOU HAVE THE RIGHT CONTROL

If you need the Mini-MOD-CNC to do additional tasks that either are not listed or do not know how to configure them, contact Heat-Timer Corp. Sales Department either by Phone (973)575-4004, Fax (973) 575-4052, or by E-mail support@Heat-Timer.com.

INITIAL SETUP

Setting an Initial Program will ease the configuration of the Mini-MOD-CNC and will give the opportunity to utilize many of the energy saving features and give more comfortable heat when needed.

The program should consist of the following:

- Selecting the features that your system can utilize.
- Installation: Install the Control, switches and sensors. See "Installation" on page 9
- Setting the System Startup. See "Startup Settings" on page 16
- Setting the System Operating Settings. See "Operating Settings" on page 22
- Setting the Stages. See "Operating Modulating Boiler Settings" on page 26 and "Operating Staging Boiler Settings" on page 27
- Adjusting Reset Ratio and Water Offset (In Reset Mode Only). See "Reset Ratio" on page 22

SELECTING THE SYSTEM FEATURES

The Mini-MOD-CNC has been designed with Hydronic building heating, using both condensing and non-condensing boilers, as the primary purpose. With this in mind, many of the Mini-MOD-CNC features can be utilized to ease, enhance, and improve your system performance. Some of these features are listed in this section.

NUMBER OF STAGES FOR EACH GROUP OF BOILERS

- The Mini-MOD-CNC can be configured to control up to 4 condensing and non-condensing boilers. It can control up to 16 boiler stages using a maximum of two Mini-Extension Panels (HT# 926712-00).

MODULATION MODE

- The Mini-MOD-CNC can stage modulating boilers using one of two methods. Normal Modulation Mode, allows it to increase the modulation of the lead boiler. When the lead boiler reaches its Modulation Start point adjustment and does not satisfy the load, the Mini-MOD-CNC will start the next boiler and so on. This mode targets boilers that can run more efficient at higher modulation rates.
- The Parallel Modulation Mode can modulate several boilers together as one large boiler. This mode is useful for boilers that are more efficient at lower firing rate as in many condensing boilers.

MODULATING SIGNAL

- The Mini-MOD-CNC is designed to accurately control the modulation output from 0 to 100% for either current (4-20mA) or voltage (0-5V, 0-1V, 1-5V, 2-10V) motors. A single Mini-MOD-CNC can control a combination of the above modulation motors.

AUTOMATIC ROTATION AMONG BOILERS

- Rotating the first burner to be activated on a call for output promotes even wear on all burners. The Mini-MOD-CNC has three modes of rotation: Manual, Last-ON, or Time; automatically rotating every selected time period from every hour to every 60 days.

SETBACK OR DAY/NIGHT SCHEDULING

Two Setback modes are available for the Mini-MOD-CNC:

- The Day/Night Scheduling provides an adjustable time-based schedule for the Setback (only available when Shutdown or Tstat is selected as the Setback/Shutdown Startup option). See "Shutdown/Tstat/Setback Mode" on page 19.
- The Setback mode uses an external signal to switch the operation of the Mini-MOD-CNC in and out of setback mode.

SYSTEM RUN-ON

- This feature lets the Mini-MOD-CNC run the SYS relay for a longer period after the boilers have been turned off. When this relay is used to control a pump, it helps in dissipating the excess heat from the boilers combustion chamber.

INSTALLATION

Each of the Mini-MOD-CNC or Mini-Extension consists of three primary enclosure components.

- **The Enclosure Display Module:** contains the display, buttons, LEDs and electric wiring terminals. It has two screws to hold it to the base. A program configuration switch, used to adjust Mini-MOD-CNC settings, is placed above the terminals. This switch is enclosed with the enclosure wiring cover for security. Wiring terminals are of the plug-in type to ease installation and removal.
- **The Enclosure Base:** contains the holes to mount and hold the control against the wall or any flat surface. All other enclosure components mount on the base. The bottom section of the Enclosure Base contains the wiring chamber with knockouts on the bottom to ease installation.
- **The Enclosure Wiring Cover:** seals the wires from the external environment. It has two screws to hold it to the base and a hole to secure a lock on the wiring enclosure. A plastic web that separates the wiring chamber into high and low volt sections has been provided.

MOUNTING THE ENCLOSURE

- Select a location near the equipment to be controlled.
- The surface should be flat and sufficiently wide and strong to hold the Mini-MOD-CNC or the Mini-Extension.
- Keep the control away from extreme heat, cold, or humidity. Ambient operating temperature is from 20 to 120°F.
- Remove the Enclosure Wiring Cover from the control enclosure by removing the two bottom screws.
- Remove the Enclosure Display Module by removing the enclosure middle screws.
- Screw the Enclosure Base to the surface through the upper and lower mounting holes on the back of the enclosure.
- Replace the Enclosure Display Module and replace the enclosure middle screws.
- Do not replace the enclosure wiring cover until all wiring is done.
- When purchasing a padlock for the enclosure, the maximum shank diameter should not exceed ¼"

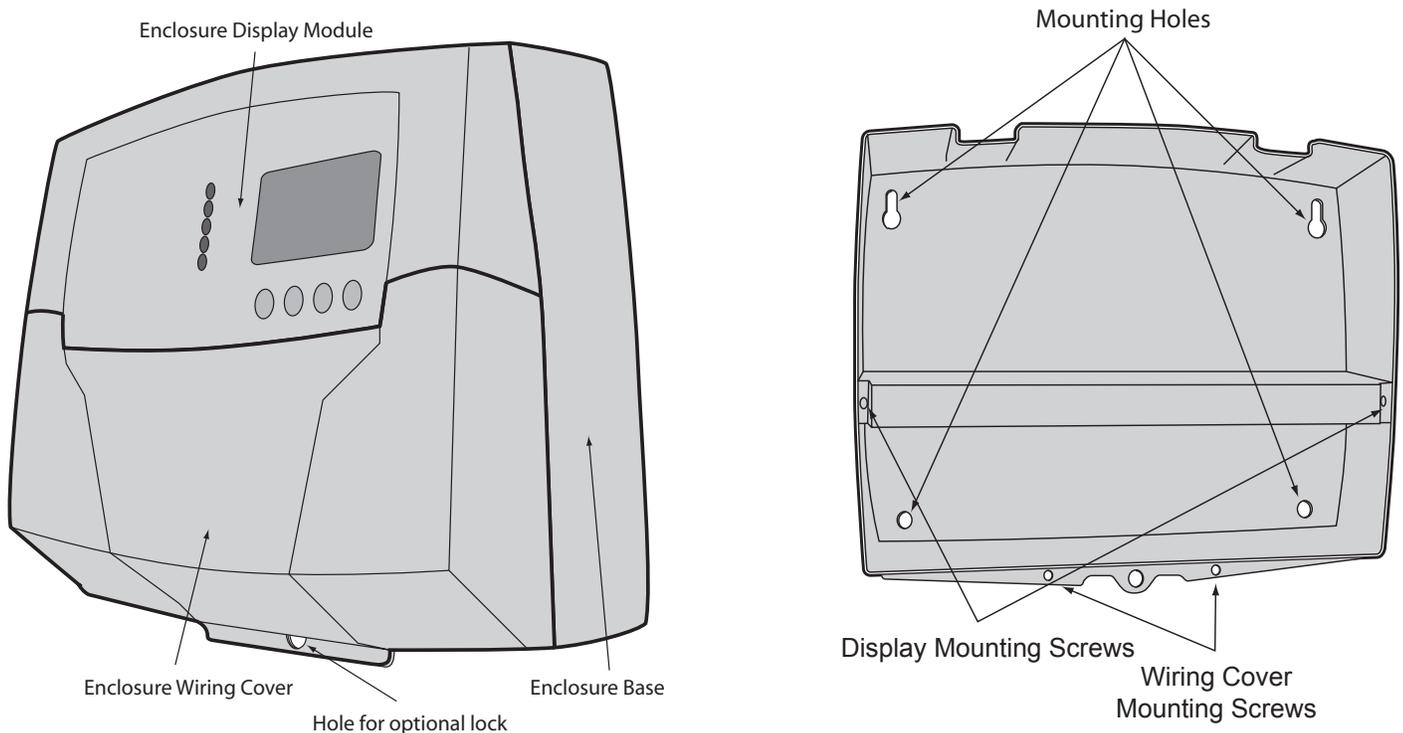

INSTALL THE SENSORS

SYSTEM SENSOR (HSS) INSTALLATION

- Only use a Standard Brass Tube sensor (HT #904250-00).
- The sensor wires can be extended up to 500' using a shielded 2-conductor cable (Belden #8760 or equivalent). Do not ground the shield at the sensor but at the panel using one of the terminals marked with an "O".
- Do not run sensor wires in conduit with line voltage wiring.
- Install a 3/8"ID 1/2"NPT immersion well (HT #904011-00 or equivalent).
- Insert the sensor in a well approximately 10' feet past the last boiler on the common supply header but before any major takeoffs.
- The sensor must be located where it sees the output of all the boiler stages. If a boiler is piped so that the sensor does not see its output, the Mini-MOD-CNC will not sequence the boilers correctly.
- The sensor can also be installed on the return to the boilers after all major returns and before any boiler. However, when setting the reset ratio and the offset, the user must consider the temperature drop across the building loop.

Immersion Heating System Sensor

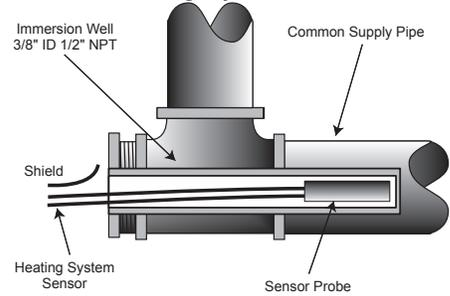

⚠ ALERT

If the System Sensor can not sense the correct water temperature, the Mini-MOD-CNC will not provide comfortable heat levels.

OUTDOOR SENSOR INSTALLATION

- Only use the Heat-Timer sensor included with the unit (HT# 904220-00) .
- Locate the sensor in the shade on the north side of the building. The sensor should never be in direct sunlight.
- Be sure the location is away from doors, windows, exhaust fans, vents, or other possible heat sources.
- The sensor should be mounted approximately 10' feet above ground level.
- Adhere the Outdoor Label provided to the back of the sensor base.
- Use the Enclosure Base bottom knockout for the conduit. Use the locknut to hold the conduit and enclosure base together. Screw the cover to the base.
- If screws are used to affix the enclosure to the wall, make sure to seal around the sensor and wall except from the bottom.
- The sensor wires can be extended up to 500' using shielded 2-conductor cable (#18/2). Do not ground the shield at the sensor but at the control using the terminal marked with an "O".
- Do not run sensor wires in conduit with line voltage wiring.

Outdoor Sensor

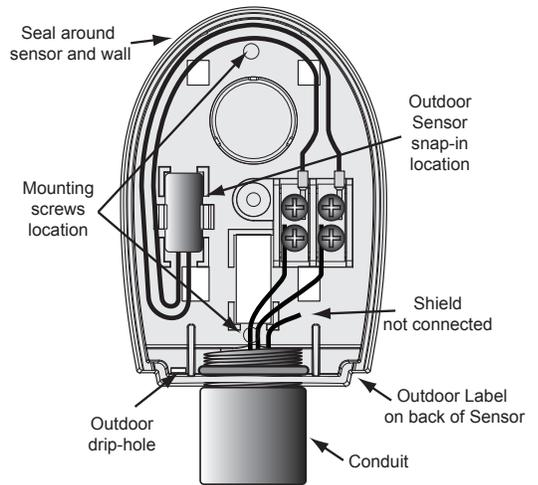

⚠ ALERT

Determining the proper location of the Outdoor Sensor is very important. The Mini-MOD-CNC will base the heat on the outdoor temperature information it receives from this location. If the sensor is in the sun, or covered with ice, its reading will be different from the actual Outdoor temperature (OD).

WIRING

- All wiring must enter the enclosure through the bottom knockouts.
- Class 1 voltage wiring must utilize a different knockout and conduit from any Class 2 voltage wiring.

WIRING THE POWER

(TERMINALS 1, 2)

- Bring the 120VAC 60Hz power wires through the bottom left knockout of the enclosure.
- Connect the hot line to terminal marked L.
- Connect the neutral line to the terminal marked N.
- Heat-Timer recommends installing a surge suppressor on the power source to the Mini-MOD-CNC.

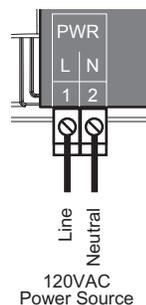

⚠ WARNING

Class 1 voltages must enter the enclosure through a different opening from any Class 2 voltage wiring. Heat-Timer recommends installing a surge suppressor on the power source to the Mini-MOD-CNC.

WIRING THE SENSORS

⚠ WARNING

Connect the shield at the control terminal end and cut the shield wire at the sensor end.

SYSTEM SENSOR WIRING

(TERMINALS 27, 28)

- A Mini-MOD-CNC must be connected to a System temperature sensor (HT #904250-00 provided) located in the common header. The sensor must be inserted in a 3/8 ID well (HT #904011-00 or equivalent).
- Temperature sensor wires can be extended up to 500' by splicing its wires with a shielded 2-conductor cable (Belden #8760 or equivalent (#18/2)).
- Temperature sensors have no polarity. Connect the two wires from the sensor to the Mini-MOD-CNC terminals marked *SYSTEM TEMP 27, 28*.
- Connect the sensor shield to the circled terminal 28 with one of the sensor wires.

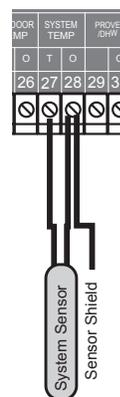

OUTDOOR SENSOR WIRING

(TERMINALS 25, 26)

- The Mini-MOD-CNC will vary the system Set Point based on outdoor temperature. In addition, the outdoor sensor is used as an Outdoor Cutoff. The Mini-MOD-CNC will disable all boilers when the outdoor temperature is above the adjustable Outdoor Cutoff temperature.
- For an outdoor sensor use the outdoor sensor provided (HT #904220-00).
- The sensor wires can be extended up to 500' using shielded 2-conductor cable (Belden #8760 or equivalent (#18/2)).
- Temperature sensors have no polarity. Connect the wires from the outdoor sensor to the Mini-MOD-CNC terminals marked *OUTDOOR TEMP - 25, 26*.
- Connect the shield to the circled terminal 26 with one of the sensor wires.



WIRING THE SHUTDOWN, TSTAT, OR SETBACK

(TERMINALS 31, 32)

- The Shutdown will be available when selected as the Shutdown/Tstat/Setback mode from the Startup menu. See "Shutdown/Tstat/Setback Mode" on page 19. This will provide the user with an adjustable Day/Night Schedule. See "Day/Night Schedules" on page 28.
- The Shutdown feature can be used whenever it is desirable to turn off the Mini-MOD-CNC stage outputs from a remote location or another controller (i.e. EMS input).
- The Tstat option, when selected from the Shutdown/Tstat/Setback startup menu, offer the capability of controlling the operation of the Mini-MOD-CNC based on a thermostat input. This will provide the user with an adjustable Day/Night Schedule.
- The thermostat will send the Mini-MOD-CNC a call for heat by shorting terminals 31 and 32.

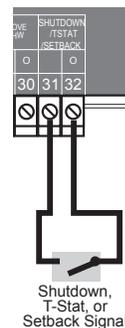

- When the Shutdown input is enabled by closing the dry contact, or when the Tstat input is disabled by opening the dry-contact, all active modulating boilers will immediately modulate down to low for the Soft-Off period, then turn off. All staging boilers will turn off immediately.
- The System Output relay will remain active until the System Run-On Delay expires and then it will turn off.
- When Setback is selected in the Startup, a BMS/EMS or external clock can provide a Setback signal using these input terminals. See "Shutdown/Tstat/Setback Mode" on page 19. No Day/Night Schedule will be available when Setback is selected from the Shutdown/Tstat/Setback mode in the Startup menu.
- The signal must be a dry contact only. No voltage can be placed across the *SHUTDOWN/TSTAT/SETBACK* terminals.
- Bring the two wires from the dry contact to the terminals marked *SHUTDOWN/TSTAT/SETBACK- 31,32*.

WIRING THE PROVE

(TERMINALS 29, 30)

- The Prove feature is provided to check system component operation and must be selected in the Startup Menu from the Prove/DHW Sharing menu. See "Prove/Domestic Hot Water (DHW) Priority" on page 19.
- A typical use of this feature is to check for pump flow or combustion air damper status before firing any boiler.
- If the PROVE input is open on a call for heat, the Mini-MOD-CNC will enable only the System Output. All boiler outputs will be off when the *PROVE* input is open.
- A factory-installed jumper provides the System Prove signal. Do not remove the jumper unless it will be replaced by a System Prove signal or these terminals are to be used for DHW call input.
- Bring the two wires from the dry contact to the terminals marked *PROVE - 29, 30*. No voltage can be placed across the *PROVE* terminals
- Prove Input terminals can accept a dry-contact signal only. No voltage can be placed across these terminals.

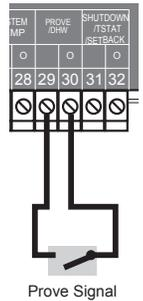

⚠ WARNING

The PROVE input cannot be used as a safety limit. All equipment must have its own certified limit and safety controls as required by local codes. If Prove is selected in the startup menu, no boiler stage will start unless Prove terminals are shorted. DO NOT remove the PROVE jumper supplied unless replacing it with a Prove signal.

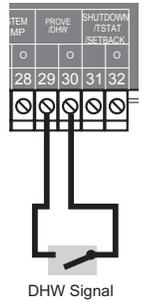

WIRING THE DOMESTIC HOT WATER (DHW) CALL

(TERMINALS 29, 30)

- DHW can be used to raise system Set Point to the DHW Set Point as well as manage the System Pump according to the DHW Priority setting. One of the DHW options must be selected from the Prove/DHW Sharing Startup menu. See "Prove/Domestic Hot Water (DHW) Priority" on page 19.
- Wire an aquastat or a control to provide dry-contact closure on the *DHW Call* terminals.
- Remove the jumper on the *DHW* terminals for proper operation.
- DHW Call terminals can accept dry contact signals only. No voltage can be placed across these terminals.

WIRING THE SYSTEM OUTPUT

(TERMINALS 3, 4)

- The SYS output relay will energize whenever the outdoor temperature is below the Outdoor Cutoff.
- The SYS relay will remain constantly energized while the outdoor temperature is below the Outdoor Cutoff.
- When the outdoor temperature rises 2°F above the Outdoor Cutoff, the SYS output will remain energized for the period set by the System Run-On. See "System Run-On" on page 24.
- In addition, the System output will energize during summer DHW calls when DHW No Priority is selected. See "Prove/Domestic Hot Water (DHW) Priority" on page 19.
- The SYS output has one Normally Open (N.O.) relay contact rated for (1/8HP).
- The N.O. contacts are dry contacts only. They do not source any voltage.
- Class 1 voltages must enter the enclosure through a different opening from any Class 2 voltage wiring.

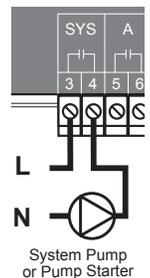

WIRING THE BOILERS

- When wiring condensing and non-condensing boilers make sure that condensing boilers utilize the first stages and non-condensing boilers will utilize the following stages. That is, if the installation had two condensing modulating boilers and two non-condensing staging On/Off boilers, Stage A and B will be used by the condensing boilers while C and D will be used by the non-condensing boilers.

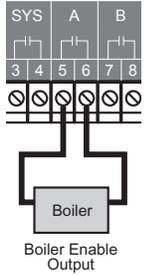

WIRING ON/OFF BOILER OUTPUTS

(A TERMINALS 5, 6), (B TERMINALS 7, 8), ...

- Each boiler output (A through D) has one Normally Open (N.O.) relay contact.
- The N.O. contacts are dry contacts only. They do not source any voltage.
- Wire the N.O. relay contacts in series with the unit's limit circuit.
- Class 1 voltages must enter the enclosure through a different opening from any Class 2 voltage wiring.
- Note that some modulating boilers may not require the use of these outputs.

WIRING MULTI-STAGE BOILER OUTPUTS

(A TERMINALS 5, 6, 7, 8), ...

- Each stage output (A through D) has one Normally Open (N.O.) relay contact that does not source any power.
- Wire each of the N.O. relay contacts to its respective boiler stage. Note that on the display of the Mini-MOD-CNC each staging boiler will consist of multiple letters. The letters represent outputs that should be wired to that boiler. The first letter should be wired to the lowest firing stage and the next letter to the next stage and so on. See "Boiler Status" on page 30.
- Class 1 voltages must enter the enclosure through a different opening from any Class 2 voltage wiring.

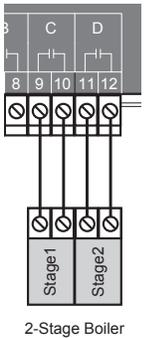

WIRING TO MODULATING OUTPUT

The Mini-MOD-CNC can modulate any combination of the following boiler signals. The Modulating Output Type must be selected properly before connecting any output wires to avoid damaging components. See "Modulating Output Type" on page 18. Some modulating boilers may require the use of the relay stage outputs. See "Wiring the Boilers"

WIRING THE 4-20mA MODULATING MOTORS

(A TERMINALS 13, 14), (B TERMINALS 16, 17),...

- The Mini-MOD-CNC can operate up to four 4-20 mA modulating motors.
- The Mini-Extension can operate up to six 4-20 mA modulating motors.
- The Mini-MOD-CNC and the Mini-Extension sources 24VDC excitation voltage for the 4-20mA signal.
- Wire the (-) from the modulating motor to the boiler terminal on the Mini-MOD-CNC marked (GND). That is for boiler A, the modulating (-) terminal will be 13.
- Wire the (+) from the modulating motor to the boiler terminal on the Mini-MOD-CNC marked (mA). That is for boiler A, the modulating (+) terminal will be 14.

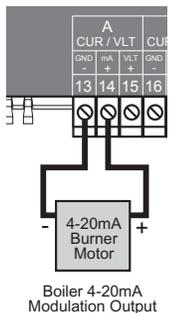

WIRING THE VOLTAGE MODULATING MOTORS

(A TERMINALS 13, 15), (B TERMINALS 16, 18),...

- The Mini-MOD-CNC can operate up to four 0-5V, 0-10V, 1-5V, or 2-10V modulating motors.
- The Mini-Extension can operate up to six 0-5V, 0-10V, 1-5V, or 2-10V modulating motors.
- Wire the (GND) from the modulating motor to the boiler terminal on the Mini-MOD-CNC marked (GND). That is for boiler D, the modulating (GND) terminal will be 22.
- Wire the (V+) from the modulating motor to the boiler terminal on the Mini-MOD-CNC marked (VLT+). That is for boiler D, the modulating (V+) terminal will be 23.

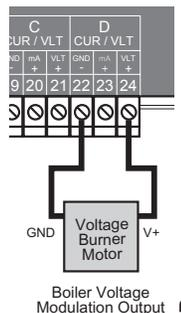

⚠ ALERT
 To set the Mini-Extension to a specific letter, remove the wiring cover and switch the Ext A/Ext B to the desired letter. **DO NOT** set both extensions to the same letter to avoid errors.

CONNECTING TO THE MINI-EXTENSION PANELS

- The Mini-MOD-CNC is equipped with a 6-pin phone socket (RS485) to connect to extension panels and . The Mini-Extension is equipped with two 6-pin phone sockets to connect to Mini-MOD-CNC and an additional Mini-Extension.
- Set each Extension to a different letter (EXT-A or EXT-B). The Mini-MOD-CNC will assign the stage letters based on the extension letter selected.
- Extension A will operate stages E - J and all the LEDs will be Green. However, Extension B will operate stages K - P and all the LEDs will be Red. See "Mini-Extension Layout" on page 5.
- Configure the Modulating and Sequencing Output Types after connecting the Extension panels to be able to configure their outputs. See "Modulating Output Type" on page 18
- Only use the cable provided for proper operation.

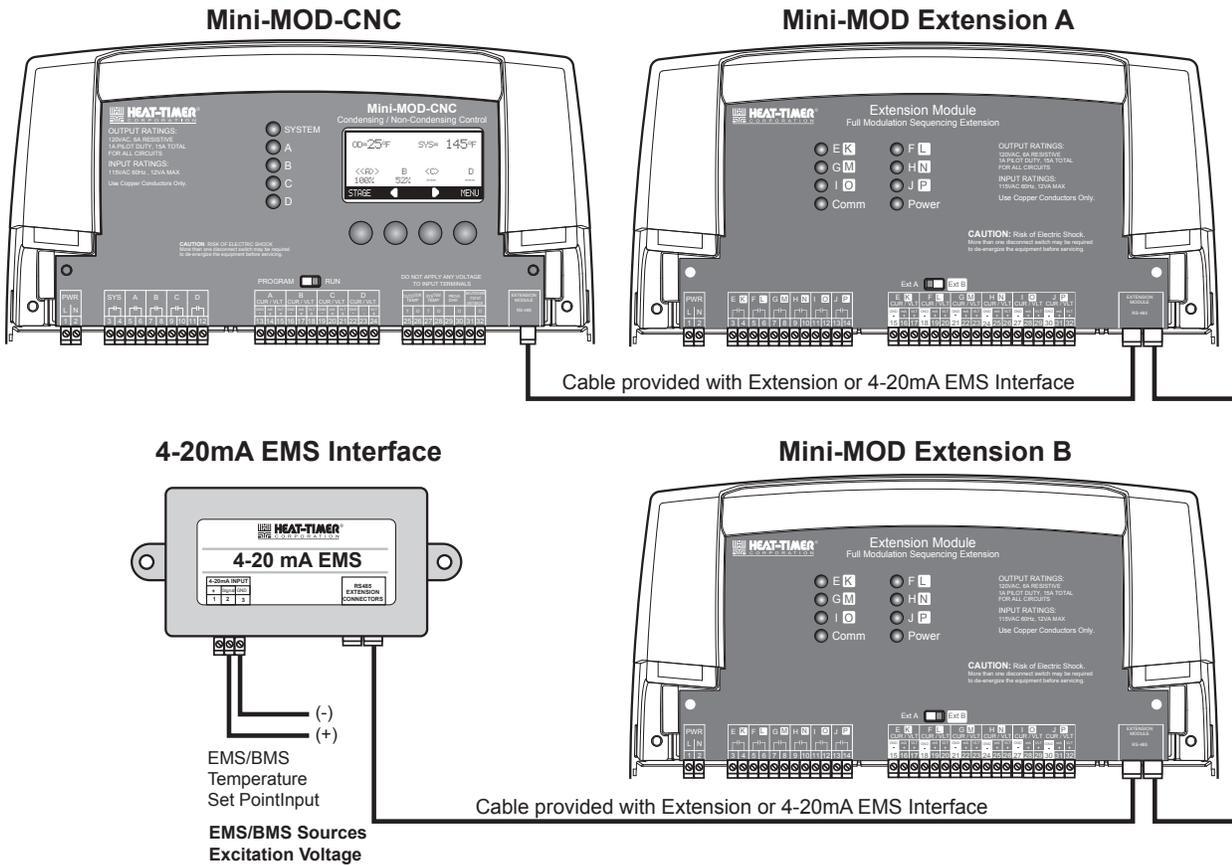

CONNECTING TO THE 4-20MA EMS INTERFACE

- The Mini-MOD-CNC is equipped with a 6-pin phone socket (RS485) to connect to extension panels and 4-20mA EMS Interface. The 4-20mA EMS Interface is equipped with two 6-pin phone sockets to connect to Mini-MOD-CNC and an additional Mini-Extension.
- Set Sensor Type to either of the two EMS options. See "Sensor Type" on page 16.
- The interface must be ordered separately.
- Only use the cable provided for proper operation.

STARTUP SETTINGS

PROGRAM CHANGE SWITCH SETTING

To be able to change the Mini-MOD-CNC settings the Program/Run Switch must be set to Program. The switch is located under the Enclosure Wiring Cover for security. The Enclosure Wiring Cover can be secured using a lock.



STARTUP SEQUENCE

Button: MENU/<System Startup>

- When powered, the Mini-MOD-CNC performs a self diagnostics-test on its components.
- On the first power up, the System Startup screen will appear after the initialization is complete. If it doesn't, the Mini-MOD-CNC has already been configured.
- The System Startup menu sets the main parameters that relate to the heating application. These settings must be set by the installer.



SENSOR TYPE

Reset °F, Reset °C, EMS °F, EMS °C

Default: Reset °F

Button: MENU/<System Startup>/.../Sensor Type

- The same Heat-Timer temperature sensor can display in either °F or °C.
- If any of the Reset options is selected, the control will use outdoor reset to calculate the Target Temperature.
- If any of the EMS options is selected, the control will require the use EMS 4-20mA Interface (HT# 926741-00).
- Selecting any of the °F options will display all temperatures in degrees Fahrenheit.
- Selecting any of the °C options will display all temperatures in degrees Celsius.



SWITCH MODE = Target Temperature

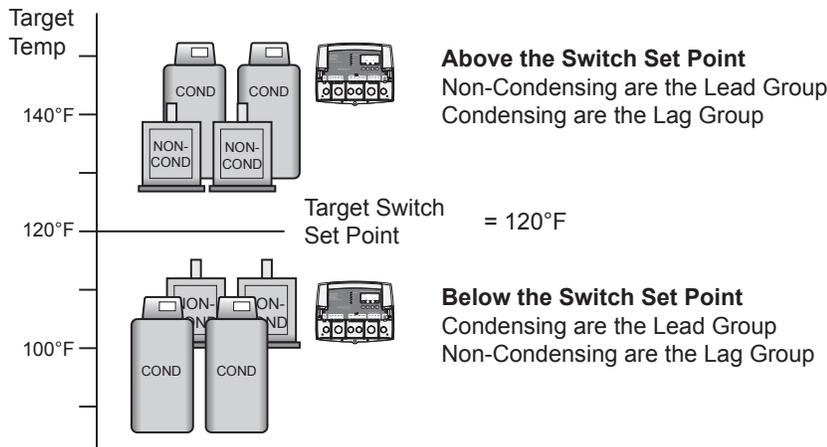

SWITCH SET POINT

Adjustable from 0°F/ -18°C to 200°F/ 94°C

Default: 150°F/ 66°C

Button: MENU/<System Startup>/.../Sensor Type/Switch Setpoint

- It is the Target Temperature Set Point at which the Mini-MOD-CNC will switch between Condensing Boiler Group and Non-Condensing Boiler Group.
- The Condensing Boiler Group will be the lead group when the Target Temperature is below the Switch Set Point. However, the Non-Condensing Group will be the lead group when the Target Temperature is above the Switch Set Point.



SWITCH DIFFERENTIAL

Adjustable from 5F° / 3C° to 20F° / 11C°

Default: 5F° / 3C°

Button: MENU/<System Startup>/.../Switch Setpoint/Switch Diff

- The Switch Differential controls the group switching. It allows the Target Temperature to drop a specified number of degrees below the Switch Set Point before changing the lead group over.
- The Switch Differential should be set to a high setting to reduce the switching frequency between the Condensing and Non-Condensing Boiler Groups, particularly if no Switch Delay was set. See next setting.



SWITCH DELAY

Adjustable from 0.0 to 12.0 Hours

Default: 0.5 hours

Button: MENU/<System Startup>/.../Switch Setpoint/Switch Diff/Switch Delay

- The Switch Delay is an additional layer of assurance used to reduce the intermittent change of the lead group.
- To switch the lead group when the temperature is dropping, the Target Temperature must drop below the Switch Set Point less the Switch Differential and remain below the Switch Set Point for the complete Switch Delay period before the switching of the lead group could take effect. That is, if the Switch Set Point was set to 135°F, and the Switch Differential was set to 5F°, then the Target Temperature must drop below 130°F for the complete Switch Delay for the lead group to change from condensing to non-condensing.
- To switch the lead group when the Target Temperature is rising, the Target Temperature must rise above the Switch Set Point for the complete Switch Delay before the switching of the lead group could take effect.
- Note that if the Switch Delay was set to 0.0 hours, the Mini-MOD-CNC will utilize its built-in delays. These delays vary between 3 to 15 minutes based on the Boiler Types used.



HEAVY LOAD SEQUENCE 2ND GROUP

Yes, No

Default: Yes

Button: MENU/<System Startup>/.../Switch Delay/Heavy Load Seq#2 Group

- This option makes the second group of boilers act as a backup in heavy load conditions. Thus, allowing them to start after all lead group boilers have run at their maximum capacity.
- If the system was designed to operate both groups of boilers in heavy load conditions, then select Yes.
- Selecting No will only allow the lead group to operate. The secondary group will remain off even if the system cannot reach the desired set point.



CONDENSING BOILER TYPE

Modulating, Staging

Default: Modulating

Button: MENU/<System Startup>/.../Heavy Load Seq#2 Group/Condensing Boiler Type

- Select the appropriate boiler type from the list. Each of the types will be followed by a related additional configuration settings to adjust.



CONDENSING AND NON-CONDENSING BOILER NUMBER

Adjustable from 1 to 15

Default: 1

Button: MENU/<System Startup>/.../Condensing Boiler Type/ Condensing Boiler Number

- Select the number of condensing boilers. These boilers will occupy the first letters of the wiring stages on the Mini-MOD-CNC starting with Stage-A.
- Then, select the number of non-condensing boilers later in the Startup menu. See "Startup Menu Sequence" on page 15.



MODULATING BOILER SETTINGS

MODULATING OUTPUT TYPE

4-20mA, 0-5V, 0-10V, 1-5V, or 2-10V Outputs

Default: 4-20mA

- If either of the Condensing or Non-Condensing Boiler Groups was set to Modulating as the Boiler Type, the Mini-MOD-CNC will offer the capability of controlling a variety of modulating signals. Each boiler can be configured to have a different modulating signal.
- The modulating output for each boiler can be configured to 4-20mA operation (Current) or any of the voltage ranges (0-5V, 0-10V, 1-5V, 2-10V). Check the modulating boiler to determine its control requirements.
- When using the Mini-Extension, connect it to the Mini-MOD-CNC prior to configuring the Output Type. Otherwise, the Mini-MOD-CNC might not recognize them properly.

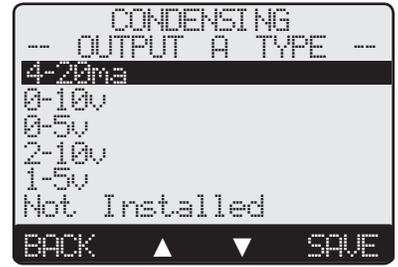

MODULATING MODE

Normal, Parallel

Default: Normal

- Some modulating boilers perform better at higher modulation. For these units, it is advantageous to run one unit at high modulation than several units at lower modulation. If the units used are of this type, select Normal. This is the recommended setting for typical steel and cast iron boilers or boilers with low turndown ratios.
- There are many condensing boilers that run more efficiently at lower modulation. If it is more energy efficient to run several units at lower modulation than one at high, select Parallel. This is typically used on water-tube boilers, low mass boilers, or boilers with high turndown ratios.
- For best Parallel performance, set the Modulation Start % to be equivalent to the lowest firing rate of the boiler multiplied by 2. That is, if the lowest firing of the boiler was 20%, set your Modulation Start% to 40%. See "Modulation Start %" on page 32.
- If Parallel is selected, it is preferred to set the Lag Delay to 0. See "Lag Delay" on page 26.

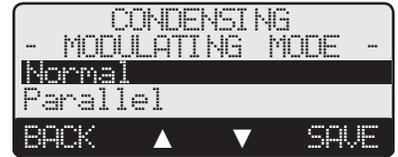
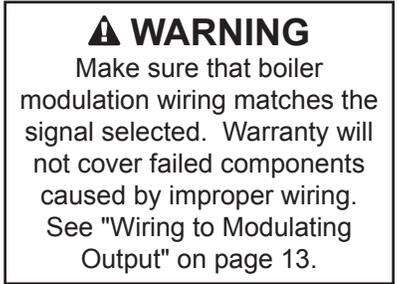

SEQUENCING BOILER SETTINGS

SEQUENCING OUTPUT TYPE

On/Off, 2-Stage, 3-Stage, 4-Stage Outputs

Default: On/Off

- The Mini-MOD-CNC can sequence any type of multi-stage boiler starting with a single On/Off and up to a 4-stages. Just select the number of stages per boiler from this menu option.
- The number selected applies to all sequencing boilers within that group whether it is condensing or non-condensing.



STAGING MODE

Lo/Hi/Lo/Hi, Lo/Lo/Hi/Hi

Default: Lo/Hi/Lo/Hi

- During low load conditions, some boilers run more efficient when the lower stages are energized alone than with the higher stages. For these types of boilers select Lo/Lo/Hi/Hi. Then, the Mini-MOD-CNC will sequence the lower stages of all boilers their Mode is set to Auto before sequencing the higher stages.
- For the rest of the boiler types, the Lo/Hi/Lo/Hi should allow the staging of the lower stage of the lead boiler followed by the higher stage of the same boiler. Then when more stages are needed, it will fire the lower stage of the lag boiler followed by the higher stage of the lag boiler.



PROVE/DOMESTIC HOT WATER (DHW) PRIORITY

Prove, DHW Priority, DHW No Priority, No Priority (Summer)

Default: Prove

Button: MENU/<System Startup>/.../Prove-DHW Sharing

- This setting determines the functionality of Input Terminals 29 and 30.
- When Prove is selected, the Mini-MOD-CNC will not start any boiler unless Prove terminals are shorted/closed. However, it will allow the System relay to function normally.
- Using the terminals to connect to an aquastat for a Domestic Hot Water call and selecting any of the DHW options will raise the calculated water temperature to the DHW Set Point (See next setting).
- The Domestic Hot Water Priority option de-energizes the System relay during domestic hot water calls for a period of one hour. If after the priority period the DHW call did not expire, the System relay will energize providing heat to the building and the temperature target will remain at the DHW Set Point. After the DHW call ends, the set point will drop to satisfy the reset ratio or set point.
- Domestic Hot Water No Priority option allows the System relay to remain energized during a domestic hot water call (aquastat call on terminals 29 and 30). However, in Summer, Shutdown, No Tstat call for heat, or when outdoor temperature is above Outdoor Cutoff, a DHW call will energize the System relay. After the DHW call terminates, the System relay will continue to run for the System Run-On period before turning off.
- Domestic Hot Water No Priority (Summer) behaves the same as the DHW No Priority. The only difference is that in Summer, Shutdown, No Tstat call for heat, or when outdoor temperature is above Outdoor Cutoff, a DHW call WILL NOT energize the System relay except for the Run-On delay after the DHW call ends.

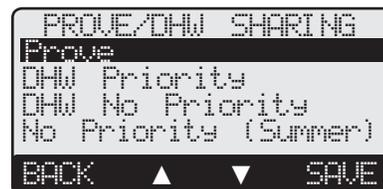

DOMESTIC HOT WATER SET POINT

(AVAILABLE WITH ANY OF THE DHW PRIORITY OPTIONS)

Adjustable from 140°F/ 60°C to 200°F/ 93°C

Default: 180°F/ 82°C

Button: MENU/<System Startup>/.../DHW Set Point

- On a DHW call, the Mini-MOD-CNC will raise the target to the DHW Set Point until the DHW call expires.



SHUTDOWN/TSTAT/SETBACK MODE

Shutdown Input, Tstate Input, Setback Input

Default: Shutdown Input

Button: MENU/<System Startup>/.../Setback\Shutdown

- The Mini-MOD-CNC has two levels of heat, a Normal/Day and a Setback/Night. The Normal/Day is good for when buildings are occupied and people are active. The Setback/Night holds a lower system temperature for night periods or when buildings are unoccupied.



- When Shutdown or Tstat is selected, the Day/Night Schedules will be available in the operating menu. See "Shutdown/Tstat/ Setback Mode" on page 19. Terminals 31 and 32 will function as a Shutdown (Turn off boilers when shorted) or as a Tstat (Turn off boilers when opened). However, a call for DHW will bring the boilers on.
- When Setback is selected, the External Signal option will switch the Mini-MOD-CNC to Setback mode when terminals 31 and 32 are shorted. This allows an external device or control to provide the setback signal. No scheduling or boost menu options will be available with Setback.

BOOST MODE

(NOT AVAILABLE WITH EXTERNAL SETBACK INPUT)

30 Minutes, Disabled

Default: 30 Minutes

Button: MENU/<System Startup>/.../Boost Mode



- The morning Boost is designed to return the building to comfortable ambient temperatures after the cooler Night (Setback) period. The Mini-MOD-CNC will accomplish this by running elevated water temperatures (will add Setback setting to calculated water temperature) for 30 minutes before the start of the Day schedule setting. That is, if the normal day set point at a specific outdoor was 145°F and the Setback setting was 20°F, the boost will raise the system calculated temperature to 165°F for 30 minutes before the start of the Day Schedule setting.
- If no Boost is needed, then simply select Disabled from the Boost Menu.
- Boost is only available if Shutdown or Tstat is selected as an option. See "Shutdown/Tstat/ Setback Mode" on page 19.

SENSOR FAULT

All Off, All On

Default: All On

Button: MENU/<System Startup>/.../Sensor Fault

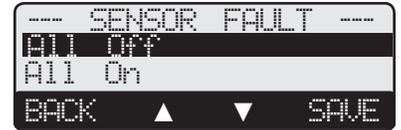

- The Sensor Fault will determine the operating status of all output stages that has their Mode set to Auto when a sensor reads Short or Open.
- When All-On is selected, the Mini-MOD-CNC will turn all boilers On to 100% when the System reads Short or Open and the outdoor temperature is below Outdoor Cutoff. However, when the Outdoor reads Short or Open, the Mini-MOD-CNC will try to maintain the Maximum Water Temperature.
- When All-Off is selected, the Mini-MOD-CNC will turn all boilers Off when either the System or the Outdoor sensor reads Short or Open. However, when the Outdoor reads Short or Open, the Mini-MOD-CNC will try to maintain the Minimum Water Temperature.

⚠ ALERT

A good practice after performing any Startup menu modification is to check all operating settings and adjustments to match the new settings.

SETTING THE CONTROL TO FACTORY DEFAULTS

To Reset the Mini-MOD-CNC control to its original factory defaults, power down the control. Hold down the two right most buttons while powering the control back up until the Total Clear Started screen appears. The Display will direct you to the Startup menu to program the control after the defaults are loaded.



NOTE: When resetting the control to original factory defaults all control settings will be overwritten and will no longer exist.

⚠ ALERT

Do not turn off power to control until all Startup settings have been made. Otherwise, the next power-up will be set to many Startup factory settings that might not fit your application.

OPERATING MENU SEQUENCE

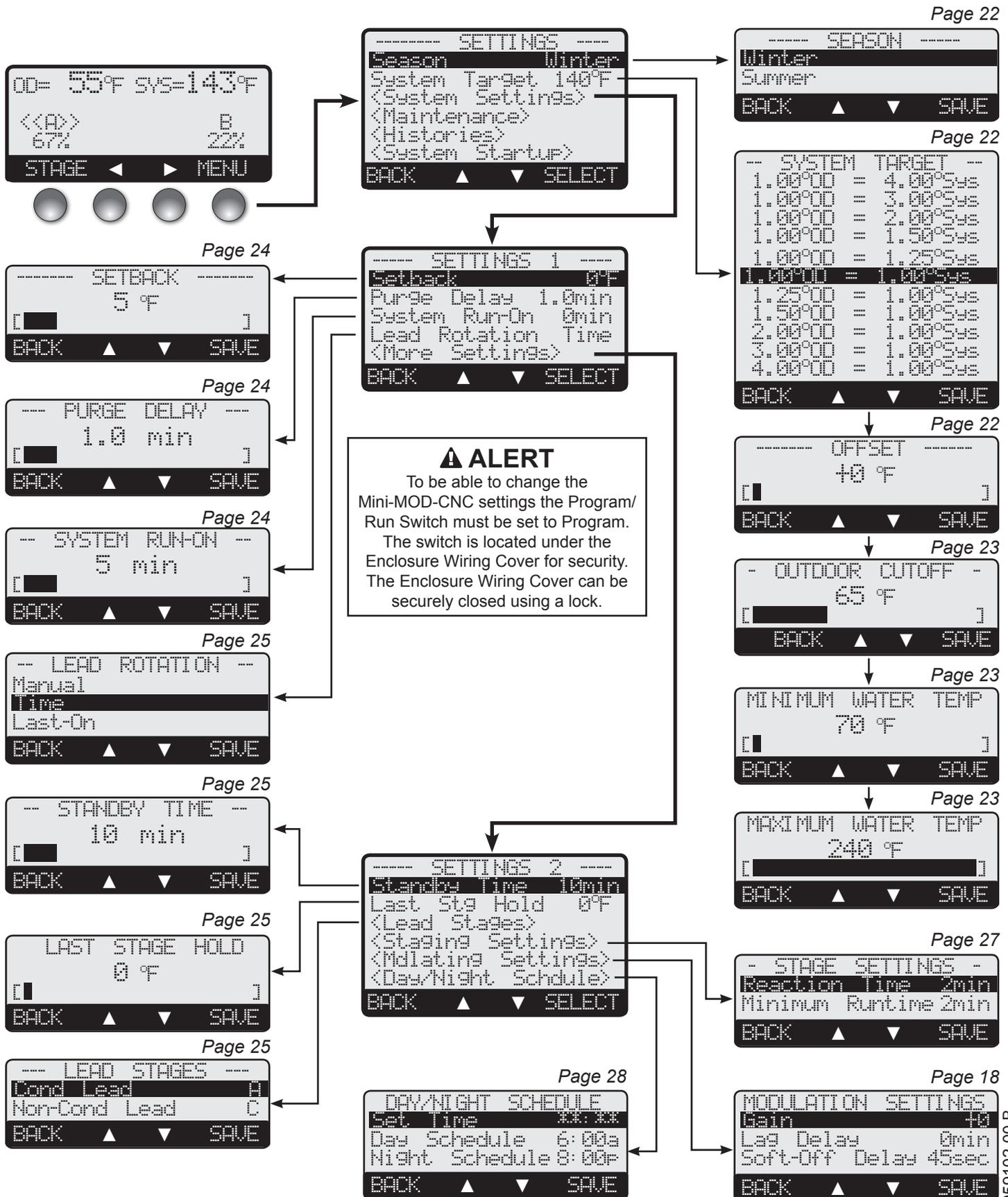

OPERATING SETTINGS

PROGRAM CHANGE SWITCH SETTING

To be able to change the Mini-MOD-CNC settings, the Program/Run Switch must be set to Program. The switch is located under the Enclosure Wiring Cover for security. The Enclosure Wiring Cover can be securely closed using a lock.



SEASON

Winter, Summer

Default: Winter

Button: MENU/Season

- The Mini-MOD-CNC will turn all boiler relays off when it is in Summer setting. However, a DHW call will bring boilers back on if needed. The Message Display Line will display *Summer* to show the status.
- When in Winter, the Mini-MOD-CNC will activate the System relay whenever the Outdoor temperature (OD) falls below the Outdoor Cutoff setting. The Message Display Line will not display any season information when in Winter.
- When the heating season is over, it is a good practice to switch the Mini-MOD-CNC to Summer setting. This will allow DHW calls to operate the boilers when needed.

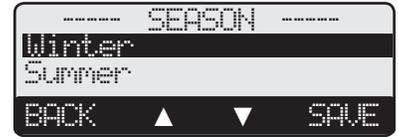

⚠ ALERT

DO NOT turn power off to the Mini-MOD-CNC when heating season is over. If you do so, the battery will run down and will have to be replaced. Instead, switch to Summer.

RESET RATIO

Adjustable 1.00°OD : 4.00°Sys to 4.00°OD : 1.00°Sys Default: 1.00°OD : 1.00°Sys

Button: MENU/Set Point

- The Reset Ratio determines how the System water temperature (SYS) will vary with Outside temperature (OD). With any of the ratios, the colder it becomes outside, the hotter the temperature of the system water. The ratios are adjustable from 1.00 (OD):4.00 (SYS) to 4.00 (OD):1.00 (SYS). See "Outdoor Reset Concept" on page 7.
- With a 1.00 (OD):4.00 (SYS) ratio, the System water temperature (SYS) will increase rapidly as the outside temperature falls, hitting the maximum of 240°F at 24°F outside temperature. With a 4.00 (OD):1.00 (SYS) ratio, the System water temperature (SYS) will increase slowly as the outside temperature falls. Even at -30°F, the system water will only be 125°F, and at 24°F outside, the system water will be 112°F. Such a low Reset Ratio might be used with radiant floor heating applications.
- With most baseboard heating applications, a 1.00 (OD):1.00 (SYS) setting is a good place to start. With a 1.00 (OD):1.00 (SYS) ratio, for every degree the outside temperature falls, the system water temperature is increased one degree.
- If required: **Adjust the RESET RATIO in cold weather.** If the ambient building temperatures are too cold in cold weather, move the ratio to a higher selection. That is, if 1.00 (OD):1.00 (SYS) was initially selected, change the selection to 1.00 (OD):1.25 (SYS). If the building temperatures are too warm in cold weather, move the ratio to a lower selection. That is, if 1.00 (OD):1.00 (SYS) was initially selected, change the selection to 1.25 (OD):1.00 (SYS).

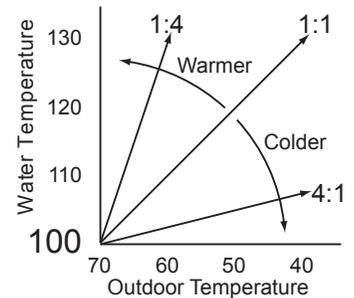
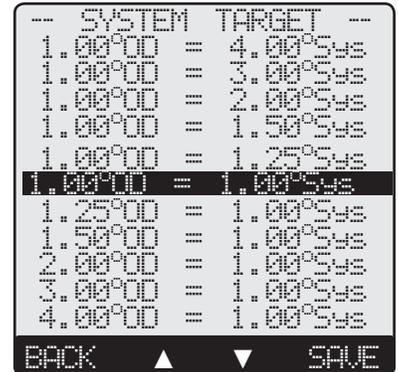

OFFSET

Adjustable from 50F°/28C° to -50F°/-28C°

Default: 0F°/0C°

Button: MENU/Set Point/Offset

- The Offset setting lets you adjust the starting points of the Reset Ratio curves. This means that, regardless of the Outdoor temperature (OD), or the Reset Ratio that has been selected, when the Offset setting is changed, that change is directly added to or subtracted from the calculated temperature. For example, if the Set Point temperature was 130°F and the Offset was changed from 0F° to 10F° (an increase of 10F°), then the Set Point temperature would increase to 140°F



- The Offset setting does not change the ratio selection. For instance, with 1.00 (OD):1.00 (SYS) Reset Ratio, the System water temperature (SYS) will always increase one degree for each degree change in the Outdoor temperature (OD). What the Offset does is add or subtract a constant temperature value. See "Outdoor Reset Concept" on page 7.
- If required: **Adjust the Water Offset in mild weather.** If the ambient building temperatures are too warm in mild weather, decrease the offset. If the ambient building temperatures are too cold in mild weather, increase the Water Offset. The rule of thumb for baseboard radiation is to change the offset 4°F for every 1°F you wish to change the building temperature. In radiant heat applications, change the offset 1°F or 2°F for every 1°F you wish to change the building temperature.

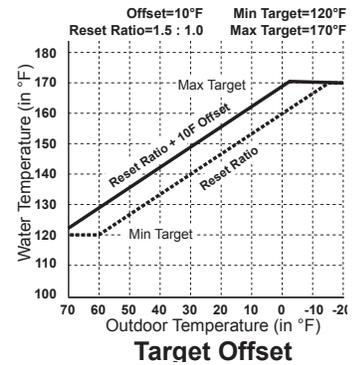

OUTDOOR CUTOFF TEMPERATURE

Adjustable: Off, from 20°F / 70°C - 100°F / 38°C, On **Default: 65°F / 18°C**

Button: MENU/Set Point/Offset/Outdoor Cutoff

- The Outdoor Cutoff screen will automatically appear after the offset has been selected.
- When the outdoor temperature falls to the adjustable Outdoor Cutoff temperature, the Mini-MOD-CNC will control and modulate boilers to hold the calculated temperature.
- When the outdoor temperature rises to the Outdoor Cutoff plus a 2°F differential, the Mini-MOD-CNC will turn all boilers off. The System relay will remain energized for the Run-On delay then de-energize.
- The Outdoor Cutoff can be set from 20°F to 100°F. In addition, it can be set to ON or OFF. In the ON position, the System Relay will run regardless of the Outdoor temperature (OD) and the burner stages will be active to hold the calculated water temperature. (Note: The lowest water temperature the Mini-MOD-CNC will circulate is 70°F. If the Outdoor Cutoff is turned ON and the Season is set to Winter, the Mini-MOD-CNC will circulate at least 70°F water even in the hottest of weather.) In the OFF position, the system pump will always be off and all burner stages will be off.



MINIMUM WATER TEMP

Adjustable from 70°F/21°C to 180°F/82°C **Default: 70°F / 21°C**

Button: MENU/Set Point/Offset/Outdoor Cutoff/Minimum Water Temp

- The Minimum Water Temperature must be set to the boiler manufacturer’s specification. The Mini-MOD-CNC will calculate the Set Point based on the Outdoor temperature (OD), the Reset Ratio, and the Offset value. The Mini-MOD-CNC will control all boilers to hold either the Set Point temperature, or the Minimum Water Temperature, whichever is higher.
- The Minimum Water Temperature must be at least 20°F lower than the Maximum Temperature (See next setting).



MAXIMUM WATER TEMP

Adjustable 90°F/21°C - 240°F/116°C **Default: 240°F/116°C**

Button: MENU/Set Point/Offset/.../Maximum Water Temperature

- This is the highest temperature heating water the Mini-MOD-CNC will circulate through the heating system.
- When using a radiation system, it should be set according to the tubing or floor manufacturer’s specification.
- The Maximum Temperature must be at least 20°F higher than the Minimum Temperature (See previous setting).
- The Maximum Temperature must be set lower than the boilers high limit for correct system temperature control.

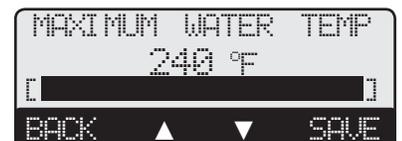

SYSTEM SETTINGS

Button: MENU/<System Settings>

Settings 1 and Settings 2 menus provide access to adjusting and fine-tuning the system for enhanced comfort and better fuel savings. The Mini-MOD-CNC behaves differently based on the selected Control Modes. See "Startup Settings" on page 16.

⚠ ALERT

To be able to change the Mini-MOD-CNC settings the Program/Run Switch must be set to Program. The switch is located under the Enclosure Wiring Cover for security. The Enclosure Wiring Cover can be securely closed using a lock.

SETBACK

Adjustable from 0F°/0C° to 75F°/42C°

Default: 0F°/0C°

Button: MENU/<System Settings>/Setback

- The Setback feature can be used to provide the Mini-MOD-CNC with a lower temperature Set Point when less load is required.
- The lower Set Point will appear on the main display indicating this condition.
- For example, if the calculated temperature is 180°F and the Setback is 20°F, then when in Setback or Night Schedule, the Mini-MOD-CNC will hold a Set Point of 160°F = 180°F - 20°F. See "Day/Night Schedules" on page 28.
- A typical use for Setback is to provide less system temperature to a building during the Night Schedule or on the weekends when the building is not occupied, but heat is still required.
- The amount of Setback selected is subtracted from the Set Point when a Setback Input Signal is received or the Night Time schedule setting started.
- If Setback is selected as the Shutdown/Tstat/Setback Mode (See "Shutdown/Tstat/Setback Mode" on page 19), the Setback will not be activated unless a Short dry-contact signal is received on terminals (31 and 32).
- If Shutdown or Tstat is selected as the Shutdown/Tstat/Setback Mode (See "Shutdown/Tstat/Setback Mode" on page 19), the Setback will be activated only when the Night Schedule time has started.

PURGE DELAY

Adjustable from 0.0min to 10.0min

Default: 1.0min

Button: MENU/<System Settings>/Purge Delay

- Many boilers go through a purge cycle before they are brought on line. When the Mini-MOD-CNC activates a boiler, it does not start to calculate its output until the Purge Delay is over. This allows the boiler to fully come online and begin producing output.
- The Purge Delay helps prevent short cycling of any newly activated burner. Once the burner is activated, it **MUST** run through the entire Purge Delay period.
- The minimum Purge Delay setting **MUST** be set to the time required by the boiler manufacturer. Time entry is in 0.1 of a minute (i.e. 1.5min will equal 90 seconds.)
- The Message Display Line will display *Purge Delay* and the amount of Purge remaining.

SYSTEM RUN-ON

Adjustable from 0min to 360min

Default: 0min

Button: MENU/<System Settings>/System run-On

- The SYS relay will energize whenever the outdoor temperature is below the Outdoor Cutoff and the Shutdown is Open or the Tstat is closed. When the Outdoor temperature rises 2°F above the Outdoor Cutoff or the control is switched to Summer and after the last burner relay has de-energized, the SYS relay will remain energized for the System Run-On period.



⚠ ALERT

When using Soft-Off and Last Stage Hold, the last boiler stage will not turn off until both parameters have elapsed. In this case, Soft-Off will start after the Last Stage Hold.



⚠ ALERT

Set Purge Delay as per boiler manufacturer recommendation.



- A common use for the System Run-On is to control a system pump in a heating system. The extra time helps transfer the boiler residual heat to the heating system.
- The System Run-On time should be set based on the size and type of the boilers and pumps used. In general, when setting the System Run-On consult the boiler and pump manufacturers for the best setting.

LEAD BOILER ROTATION

Adjustable Manual, Time (1 hr to 60 Days), Last-On Default: Time (24Hours)

Button: MENU/<System Settings>/Lead Rotation

- The Lead Boiler is the first boiler brought on when an output is needed.
- The Lead Boiler can be rotated automatically every specified time period, manually, or based on Last-On. Time rotation is recommended.
- The current Lead Boiler is shown in brackets on the main display.
- Only boilers which are set to Auto Mode can be Lead. Therefore, not all the boilers may be available when manually selecting a new Lead Boiler.



STANDBY TIME

Adjustable from 1min to 60min Default: 10min

Button: MENU/<System Settings>/<More Settings>/Standby Time

- The Standby Time only applies to boilers in Standby Mode. See "Mode" on page 31.
- A boiler can be set to be a Standby boiler using the Stage Menu.
- A Standby boiler can only be activated after all the boilers in Auto Mode have run at 100% modulation for the full Standby Time.
- Standby boilers are used for backup or extreme load conditions only. A Standby boiler can never be a Lead Boiler.
- The full Standby Time must always elapse regardless of what happens to the system temperature. Therefore, shorter Standby Times will result in smoother set point operation in extreme conditions. On the other hand, longer Standby Times may prevent a Standby boiler from firing if the other boilers can eventually meet the load, or if the load decreases.

LAST STAGE HOLD

Adjustable from 0F°/0C° to 30F°/17C° Default: 0F°/0C°

Button: MENU/<System Settings>/<More Settings>/Last Stg Hold

- The Last Stage Hold prevents short cycling of the Lead Stage during low demand periods.
- In these conditions, the system might require less output than the lowest lead Stage. When the Mini-MOD-CNC brings on the Lead Stage, the Set Point is quickly exceeded, and the Mini-MOD-CNC turns the Lead Stage off.
- To prolong the run time during this type of condition, use the Last Stage Hold setting to let the system temperature exceed the Set Point by the number of degrees selected.
- For example, with a Set Point of 160°F and a Last Stage Hold setting of 10°F, the Lead Stage boiler will de-energize after the Set Point exceeds 170°F.
- In many cases, it is better to overshoot slightly than to short cycle a boiler.
- When Soft-Off is set to other than 0 seconds, the Lead Boiler will need to remain at or exceed the Last Stage Hold for the Soft-Off period before turning off.



LEAD STAGES

Condensing Lead, Non-Condensing Lead Default: Condensing Lead

Button: MENU/<System Settings>/<More Settings>/Lead Stages

- In addition to having a lead group, each group of boilers, Condensing Group and Non-Condensing Group, will have its own lead boiler that can be selected from this menu.
- After assigning the lead boiler for each group, the lead will rotate based on the Lead Rotation option selected. See "Lead Boiler Rotation" on page 25.



OPERATING MODULATING BOILER SETTINGS

GAIN

Adjustable from -10 to +10

Default: 0

Button: MENU/<System Settings>/<More Settings>/<Modulating Settings>/Gain

- The Gain adjusts the aggressiveness of the modulating PID logic. It controls how much modulation is changed when the system temperature is different from the Set Point.
- A Gain of 0 is a good starting point for all systems.
- If during normal load conditions, the system temperature tends to oscillate significantly, decrease the Gain by two numbers (for example, from 0 to -2). Wait for at least 15 minutes before evaluating how the change has affected the system.
- If, during normal load conditions the system temperature tends to remain consistently below the Set Point (or consistently above the Set Point), increase the Gain by two numbers (for example, from 0 to 2). Wait for at least 15 minutes before evaluating how the change has affected the system.

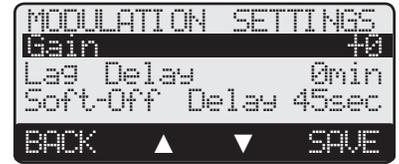

LAG DELAY

Adjustable from 0min to 60min

Default: 0min

Button: MENU/<System Settings>/<More Settings>/<Modulating Settings>/Lag Delay

- The Lag Delay requires the lead stage to remain at 100% modulation for the full period of the Lag Delay before the lag stage can be activated. For example, if the Lag Delay was set to 10 minutes, the Lead Stage must remain at 100% modulation for the full ten minutes before the lag stage could be activated. The Message Display Line will display *Lag Delay* and the remaining time.
- Set the Lag Delay to 0 min when two or more Stages will generally be needed to hold the load.
- The Lag Delay is useful in installations where one unit should usually have enough output to hold the load unless it fails or load conditions become extreme.
- The Lag Delay overrides the Modulation Start % selected for each stage. Regardless of that setting, the previous stage must reach and stay at 100% before the lag stage can be activated.
- The full Lag Delay must always elapse regardless of what happens to system temperature. Therefore, set the Lag Delay to 0 min if the object is to achieve a smooth operation and set point control using multiple units.
- Note that if Parallel was selected as the Modulation Mode (See "Modulating Mode" on page 18), this value must be set to 0 minutes to avoid having the lead boiler going to 100% modulation prior to firing the lag boiler.



SOFT-OFF DELAY

Adjustable from 0sec to 60sec

Default: 45sec

Button: MENU/<System Settings>/<More Settings>/<Modulating Settings>/Soft-Off Delay

- When a stage is no longer needed, the Soft-Off keeps that stage burner in Low Fire prior to turning it off.
- The display will show a percent that is equal to the Ignition % for the stage in Soft-Off delay. That number will blink for the Soft-Off delay period.
- If during the Soft-Off delay period the Mini-MOD-CNC needed that stage to turn back on, the stage will be released from the Soft-Off delay and resume normal operation.
- On a Shutdown initiation or Tstat termination any stage that was on will go into Soft-Off delay before fully turning off.



▲ ALERT

When using Soft-Off and Last Stage Hold, the last boiler stage will not turn off until both parameters have elapsed. In this case, Soft-Off will start after the Last Stage Hold.

OPERATING STAGING BOILER SETTINGS

REACTION TIME

Adjustable from 1 to 10 minutes

Default: 2 minutes

Button: MENU/<System Settings>/<More Settings>/<Stage Settings>/Reaction Time

- It is the amount of time it takes a single stage to affect the system.
- After the Mini-MOD-CNC turns on a stage trying to meet a set point, it will not turn on another stage until the Reaction Time has elapsed.
- To determine the optimum time, start with a hot system. Then, turn on a single stage and calculate how long it takes until the system begins to respond to that stage. That period should be set as the Reaction Time.



MINIMUM RUNTIME

Adjustable from 1 to 60 minutes

Default: 2 minutes

Button: MENU/<System Settings>/<More Settings>/<Stage Settings>/Min Runtime

- This is the minimum amount of time any stage will run.
- For the lowest stage of a unit, the Minimum Runtime starts after the purge cycle.
- The Runtime does not apply to the last stage online. The Last Stage Hold applies in that case.
- Initially, set the Minimum Runtime to half the Reaction Time.
- If the system tends to overshoot, reduce the Minimum Runtime. However, if boilers tend to short cycle, increase the Minimum Runtime.

AVOIDING CONFLICTING BOILER LIMITS

- The temperature limits set on the boilers MUST be set considerably higher than the Mini-MOD-CNC's Set Point for the reasons detailed below.
- The Mini-MOD-CNC sensor is located in a common header some distance from the boilers.
- As the temperature rises in the header and before reaching the sensor location, energy is dissipated. Therefore, the temperature in the header could be lower than that registered by boiler sensors.
- In addition to the normal drop experienced between the boiler's temperature and that read by the Mini-MOD-CNC sensor, the Last Stage Hold setting must be accounted for. The boiler limit must be set above the Set Point PLUS the Last Stage Hold PLUS the normal drop experienced in the piping.
- Using the previous example of a 10°F Last Stage Hold with a 160°F Set Point, the boilers' limits must be set enough over 170°F to prevent the boilers' internal limits being reached. In this situation, the boiler high limit should be set at approximately 180°F or higher to prevent the difference in boiler temperature vs. header temperature causing erratic operation.

⚠ WARNING

The temperature limits set on the boilers must be higher than the Mini-MOD-CNC Max Water Temp. Read the section at left for details that will prevent erratic system operation.

DAY / NIGHT SCHEDULE

DAY/NIGHT SCHEDULES

(Available when "Shutdown or Tstat" is selected from the Shutdown/Tstat/Setback Startup menu option only)

Button: MENU/<System Settings>/<More Settings>/Day/Night Schedule

- The Mini-MOD-CNC has two levels of heat. The Day (Normal) level is used when a building is occupied and people are active.
- The Night (Setback) level is used when a building is not occupied, or when people are sleeping. This setting reduces the calculated temperature by the Setback setting. See "Setback" on page 24. If the Day calculated water temperature was 150°F and the Setback was 20°F, the Night Schedule will run at (150°F - 20°F) = 130°F.
- If the Boost feature is being used, it uses the Day Schedule as the Boost ending point. See "Boost Mode" on page 20. That is, if the Day Schedule is set to start at 6:00AM, the Boost will start 30 minutes prior to the Day setting at 5:30AM. The Mini-MOD-CNC will then raise the calculated water temperature by the Setback amount. Using the previous example, at 5:30AM the Mini-MOD-CNC will raise the calculated water to 170°F = (150°F + 20°F) until 6:00AM.



SET TIME

Button: MENU/<System Settings>/<More Settings>/Set Time

- Adjust the time by selecting Set Time from the menu and then scrolling through the hours then select Save. Then, scroll through the minutes then select Save. If the hours are to be set to PM, scroll through the AM hours to reach the PM hours.



⚠ ALERT

Remember that the battery is the backup for the Time. If no power is supplied to the Mini-MOD-CNC and there was no battery or the battery had no power, time values will be lost and will need to be reset.

HISTORY

Button: MENU/<Histories>

The Mini-MOD-CNC provides users with a graphical history of the System and Outdoor temperatures for the previous 24 hours. The temperatures are sampled every 12 minutes. That is, readings of both System and Outdoor temperatures are recorded and stored every 12 minutes for the last 24 hours.

- To view the values of specific time period, use the two middle buttons to scroll to that time and read the upper left temperature.
- The first screen will be the System Temperature History. By clicking on the Next button, you'll be able to view the Outdoor Temperature History.

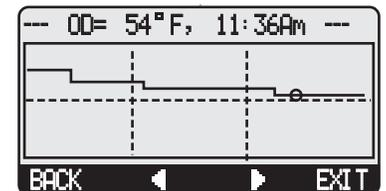
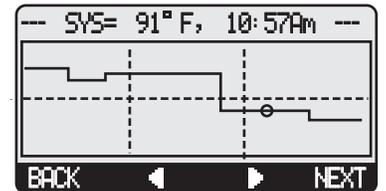

MAINTENANCE

Button: MENU/<Maintenance>

The Maintenance menu gives access to sensor and outputs trimming. In addition, you'll have access to view the Startup configuration settings.



⚠ ALERT

To be able to change the Mini-MOD-CNC settings the Program/Run Switch must be set to Program. The switch is located under the Enclosure Wiring Cover for security. The Enclosure Wiring Cover can be securely closed using a lock.

SYSTEM & OUTDOOR SENSOR TRIM

Adjustable from $-5F^{\circ}/-3C^{\circ}$ to $+5F^{\circ}/+3C^{\circ}$ Default: $0^{\circ}F$

Button: MENU/<Maintenance>/System Trim

Button: MENU/<Maintenance>/Outdoor Trim

- The Heat-Timer thermistor type sensors are very accurate, and normally require no calibration. Sometimes it may be desirable to make small adjustments to the displayed value for either the Outdoor temperature (OD) or the System temperature (SYS). The Trim setting can adjust the displayed value by $\pm 5^{\circ}F$.
- Do not use the Trim setting to make the Outdoor temperature sensor match that reported on the radio or TV. Outdoor temperature can vary widely over a broadcast range. Only trim the outdoor sensor based on an accurate thermometer reading taken where the sensor is located.

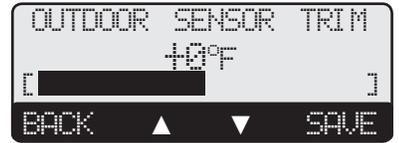
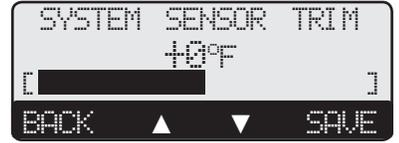

OUTPUT MODULATION TRIM

Adjustable from -1.0 to $+1.0$ Default: 0.0

Button: MENU/<Maintenance>/Output Trim

- Each of the modulating stages controlled has a separate Output Trim setting.
- Output Trim acts as an adjustment to a stage output percent to match the burner motor.
- After adjusting the Output Trim, test the operation to make sure the results match your expectation.



⚠ ALERT
DO NOT use the Output Trim for a Stage unless it is absolutely necessary. Test burner operation and modulation output matching after adjusting the Output Trim.

CONFIGURATION

Button: MENU/<Maintenance>/<Configuration>

- This menu option provides a consolidated view of the Mini-MOD-CNC's Startup and Stage settings.



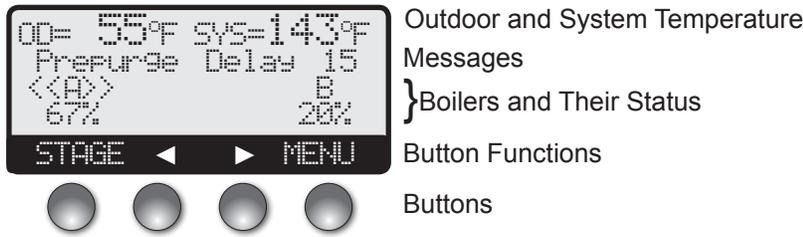

DISPLAY

The Mini-MOD-CNC display layout provides a variety of information that gives an immediate picture of the operation status. The display shows two boilers at a time. When extensions are present, the two middle buttons (◀ ▶) scroll the screen to view additional boilers. Moreover, all the information displayed can be viewed in brightly or dimly lit rooms.

- The buttons' functionality changes based on the screen and menu level. The buttons' functionality is displayed on a dark background on the screen bottom line.
- (◀ ▶) Horizontal arrows are to scroll through the available stages.
- (▲ ▼) Vertical arrows are to scroll through the menu functions when in menus or to change values of settings when in its specific screen.
- The Top line displays the Outdoor and System sensor values.
- The second line displays all messages pertaining to the operation or status. See "Display Messages".
- The third line will list the boiler stages. Any additional stages can be scrolled to using the two middle buttons. The lead boiler letter will be bracketed. See "Lead Boiler Rotation" on page 25. The lead boiler in the lead group will have two sets of brackets.
- The fourth line lists each boiler modulation or sequencing status. See "Boiler Status".

BOILER STATUS

The Mini-MOD-CNC boiler status gives immediate access to each boiler stages or modulation.

- --- Boiler is off due to no call for heat.
- <<A>> Unit A is the Lead in the Lead group.
- <C> Unit C is the Lead in the Lag group.
- C/E Mini-Extension panel is NOT communicating back to the Mini-MOD-CNC. See "Connecting to the Mini-Extension Panels" on page 14.
- mON All boiler stages are set to ON.
- mOFF All boiler stages are set to OFF.

DISPLAY MODULATING BOILER STATUS

- 97% Boiler is modulating at the indicated percentage.
- m95% Boiler Stage Mode is set to Manual Modulation to the specified percent. See "Mode" on page 31.

DISPLAY SEQUENCING BOILER STATUS

- AB Two-Stage boiler. The letters represent the stages assigned to that boiler
- High Boiler highest firing stage is active. The boiler Mode is set to either Auto or Standby.
- Med Boiler Middle stage on a 3-stage boiler is active. The boiler Mode is set to either Auto or Standby.
- Mhigh Boiler Middle High stage on a 4-stage boiler is active. The boiler Mode is set to either Auto or Standby.
- Mlow Boiler Middle Low stage on a 4-stage boiler is active. The boiler Mode is set to either Auto or Standby.
- Low Boiler lowest firing stage is active. The boiler Mode is set to either Auto or Standby.

DISPLAY MESSAGES

The Mini-MOD-CNC display layout reserved the second line for message indications. The following is a list of the most common Message Display Line information:

- Boost To 170°F The Boost has started 30 minutes before the Day Schedule setting and the Boost temperature is 170°F.
- DHW Call (180°F) There is a DHW call. The Mini-MOD-CNC will raise the system Set Point to the indicated temperature. DHW increases calculated temperature to the DHW Set Point. See "Domestic Hot Water Set Point" on page 19.
- Holding Until 150°F The Lead boiler is in Last Stage Hold. This example shows that the lead stage will turn off when system temperature reaches 150°F. See "Last Stage Hold" on page 25.
- Lag Delay: 123 The lead boiler is at 100% and the remaining purge time to start the lag boiler in seconds is 123. See "Lag Delay" on page 26.

- Outdoor Cutoff The outdoor temperature is above the Outdoor Cutoff setting. No boilers will be active for heating.
- Prove Failure After boilers have run for some time, Prove signal has ended. All boilers set to Auto or Standby will de-energize. However, the System relay will remain energized. See "Prove/Domestic Hot Water (DHW) Priority" on page 19 and "Wiring the Prove" on page 12.
- Purge Delay: 23 A boiler is in purge cycle and the remaining purge time in seconds is 23. See "Purge Delay" on page 24.
- Setback to: 130°F The Night Schedule or Setback input is active. Current Setback temperature is 130°F. See "Setback" on page 24.
- Shutdown Active The Shutdown Terminals are Shorted. No boilers will be active. See "Shutdown/Tstat/Setback Mode" on page 19 and "Wiring the Shutdown, Tstat, or Setback" on page 11.
- Summer The control is set to Summer. No heat is active. See "Season" on page 22.
- Switch in: 00:30 The switch from one group to the other will take place after 30 minutes. See "Switch Delay" on page 17.
- System Run-On: 46 The System relay is ON for the System Run-On Delay. This example shows that it will remain in System Run-On for an additional 46 seconds before turning off. See "System Run-On" on page 24.
- Tstat Call The Tstat Terminals are Shorted. Boilers will be active.
- Waiting for Prove The System relay is ON and the prove terminals are open before the lead boiler relay can energize. See "Prove/Domestic Hot Water (DHW) Priority" on page 19.

BOILER STAGE SETTINGS

Button: STAGE/

The Stage menu offers the capability of adjusting each of the boiler's operation individually.

- In most installations, all active boiler adjustments are the same, but each can be configured differently if desired.
- If the boilers are not set up properly, the Mini-MOD-CNC operation may appear to be erratic.
- When the STAGE button is depressed, the Boiler A settings menu will be shown.
- Make all the appropriate settings for Boiler A (See below).
- After completing all the settings for Boiler A (See below), you have the option of copying these settings to all other modulating boilers. Everything but the Mode -- Auto/Standby/Manual/Off/On -- will be copied.
- Then select the Next Stage option from the menu to bring up the Boiler B settings menu and make all the settings. Continue until all boilers have been set.
- If a Mini-Extension is connected to the Mini-MOD-CNC and the stages have been set through the Startup menu, then scrolling through stages using the Next Stage and Prev Stage menu options will scroll through the Mini-Extension stages as well.

Modulating Boiler Stage Menu



Sequencing Boiler Stage Menu



⚠ ALERT

To change the Mini-MOD-CNC settings, the Program/Run Switch must be set to Program. The switch is located under the Enclosure Wiring Cover for security. The Enclosure Wiring Cover can be securely closed using a lock.

MODE

Auto, Standby, Manual, Off, On

Default: Auto

Button: STAGE/Mode

- The Mini-MOD-CNC only controls the modulation of boilers set to Auto or (after a delay) those set to Standby. None of the other settings are recommended for output boilers connected to active units.
- Any stage without an active unit connected must be set to Off.
- The following list describes the MODE options:

Auto The Mini-MOD-CNC will control the boiler's operation to maintain the desired Set Point. Only boilers set to Auto can be Lead boilers.

Standby Standby boilers can only be activated when all boilers in Auto have been at 100% modulation or at High fire for the full Standby Time. Standby is generally used when you want a specific boiler to be available in extreme load conditions. Note that a Standby boiler Cannot be a Lead boiler.



- Manual** The Manual Mode should only be used when testing a boiler. Manual overrides the Prove input. For modulating boilers, the exact percent of modulation for a boiler can be set with the Manual mode. Once selected, the unit will immediately turn on and modulate to the selected percentage. For staging boilers, switching the Mode to Manual will turn on all of the boiler stages. See "Boiler Status" on page 30.
- Off** Any output Boiler A through D not connected to a physical unit should be set to Off. The Off Mode can also be used to disable units that are being serviced.
- On** The On Mode should only be used when testing a boiler. The On Mode overrides the PROVE input. Once set to On the boiler will immediately start firing at its highest rate.

IGNITION %

(Modulating Boilers Only)

Adjustable from 1% to 50%

Default: 1%

Button: STAGE/Ignition %

- The Ignition Point is the percent of modulation that must be attained before the unit can be activated.
- For most modern power draft units, the Ignition Point should be set at 1%.
- Older units or atmospheric units may require the modulating fuel valve to be open from 20-50% before proper ignition can be attained. Check with the boiler manufacturer if you are in doubt about the minimum position of the fuel valve for ignition.



MODULATION START %

(Modulating Boilers Only)

Adjustable from 0% to 100%

Default: 75%

Button: STAGE/Mod Start %

- The Modulation Start determines at what modulation percent the previous boiler (lead boiler) should be for the lag boiler to be activated.
- For example, if the Modulation Start for Boiler B is set to 75%, then when Boiler A reaches 75% modulation plus Ignition% (75% + 1% = 76%), Boiler B (if Boiler B is in Auto Mode and is not already on) will be brought on at the Ignition % level.
- When modulation is decreasing, the lag unit will remain on at the Ignition % modulation until the previous boiler reaches 40% of lag boiler's Modulation Start, or 2% above the Ignition Point, whichever is higher.
- Using the same example, as the load decreases, Boiler B would modulate down to its Ignition %. Boiler A would then modulate down to 30%. Only then would Boiler B turn off.
- If the Lag Delay is set to anything other than 0, a boiler must always go up to 100% modulation before the next boiler is activated. However, the Modulation Start % should still be set correctly, because it will be valid when modulation is decreasing.
- Heat-Timer suggests that when Parallel is selected as the Modulation Mode to set the Modulation percent equal to or slightly higher than double the Ignition %. See "Modulating Mode" on page 18. This way, the lag boiler will only start if the load is large enough for two boilers to run at the lowest modulation.



COPY SETTINGS - BOILER A ONLY

(Modulating Boilers Only)

Button: STAGE/Copy Settings

- If all the active boilers will have the same Ignition Start Point and Modulation Point, they can be set for Boiler A and then copied to the other modulating boilers.
- It is still required to select the Mode for all other boilers as the Mode is NOT copied.



⚠ ALERT

The Mode MUST be set for each boiler. The Copy Settings command will not set the Mode for the remaining boilers. Only Ignition % and Modulation Start % are copied.

TROUBLESHOOTING

SENSOR INPUTS

Display shows Sensor OPEN or SHORT

When OPEN, Check the sensor is connected and the wires are continuous to the Mini-MOD-CNC. Finally follow the procedure for Incorrect Temperature Display. When SHORT Remove the wires from the sensor terminals. The display should change to read OPEN. If it does not, the Mini-MOD-CNC may be damaged. When OPEN short the wires from the sensor terminals. The display should change to read SHORT. If it does not, the Mini-MOD-CNC may be damaged.

Display shows an Incorrect Temperature

Remove the wires from the sensor terminals. The display should change to read OPEN. If it does not, the Mini-MOD-CNC may be damaged. Take an ohm reading across the detached sensor wires. The ohm reading should correspond to the Temperature sensor Chart. If it does not, the sensor may be damaged.

Temperature Sensor Chart

TEMPERATURE		Value (in Ohms)
°F	°C	
OPEN		150000
-30	-34	117720
-20	-29	82823
-10	-23	59076
0	-18	42683
10	-12	31215
20	-7	23089
25	-4	19939
30	-1	17264
35	2	14985
40	4	13040
45	7	11374
50	10	9944
55	13	8714
60	16	7653
70	21	5941
80	27	4649
90	32	3667
100	38	2914
110	43	2332
120	49	1879
130	54	1524
140	60	1243
150	66	1021
160	71	842
170	77	699
180	82	583
190	88	489
200	93	412
210	99	349
220	104	297
230	110	253
240	116	217
250	121	187
SHORT		100

CONTROL OPERATION

No Heat

- **Season** - Make sure that the Season is set to Winter. See "Season" on page 22 and "Display Messages" on page 30.
- **Prove** - Even though, the system relay may be energized, the Mini-MOD-CNC will not energize and stage relays unless the Prove is shorted. See "Display Messages" on page 30 and "Wiring the Prove" on page 12.
- **Shutdown** - The Mini-MOD-CNC will deactivate stage outputs when the Shutdown terminals are shorted. See "Display Messages" on page 30 and "Wiring the Shutdown, Tstat, or Setback" on page 11.
- **Tstat** - The Mini-MOD-CNC will deactivate stage outputs when the Tstat terminals are open. See "Display Messages" on page 30 and "Wiring the Shutdown, Tstat, or Setback" on page 11.
- **Sensor Fault** - When the Sensor Fault is set to All Off in the startup menu, the System sensor fault (in all Sensor Type modes) or the Outdoor sensor fault (in Reset mode) will de-energize all stage relays. See "Display Messages" on page 30 and "Sensor Fault" on page 20.
- **System or Outdoor Sensor** - If the System or Outdoor sensor reading was higher than the actual temperature, the Mini-MOD-CNC might not bring any stage on. Check "Display shows an Incorrect Temperature" section.

Too Much Heat

- **Domestic Hot Water call** - The Mini-MOD-CNC will raise the temperature of the system to the DHW Set Point on a DHW call, connected to terminals 29 and 30. Check to see if there is a call for DHW and the length of time it lasts.
- **Reset Ratio and Offset** - If excessive heat occurs only in certain weather conditions, adjust the Reset Ratio and Offset. See "Outdoor Reset Concept" on page 7. If excessive heat occurs year round, reduce the Offset.
- **Boiler Mode Settings** - The Mini-MOD-CNC will only controls boilers their mode is set to Auto or Standby. Check if any boiler stage is set to Manual or On. See "Mode" on page 31.
- **Control Settings** - The Last Stage Hold will allow only the Lead boiler to stay on for an additional number of degrees. If the setting is too high, and only the Lead boiler is on, the system can over heat. Reduce the Last Stage Hold setting. See "Last Stage Hold" on page 25.

Too Little Heat

- **Reset Ratio and Offset** - If reduced heat occurs only in certain weather conditions, adjust the Reset Ratio and Offset (See "Outdoor Reset Concept" on page 7). If reduced heat occurs year round, increase the Offset.
- **Setback and Day/Night Schedule** - If reduced heat occurs only during specific hours, check the Day/Night Schedule and the Setback values. Then, reduce the Setback setting. See "Setback" on page 24.
- **Boiler Mode Settings** - The Mini-MOD-CNC will only control boilers their mode is set to Auto or Standby. Check if any boiler stage is set to Manual, Off, or Standby. See "Mode" on page 31.

Boilers are Short-Cycling

- **Lag Delay** - Increase the Lag Delay only if modulating boilers tend to short-cycle.
- **Minimum Runtime** - Increase the Minimum Runtime only if staging boilers tend to short-cycle.
- **Last Stage Hold** - Increase the Last Stage Hold only if the lead boiler tends to short-cycle.

System is Overshooting or Undershooting

- **Gain** - If the system is overshooting reduce the Gain. See "Gain" on page 26.
- **Gain** - If the system is undershooting increase the Gain.

MODULATING AND SEQUENCING BOILERS DIRECT HEATING PIPING DIAGRAM

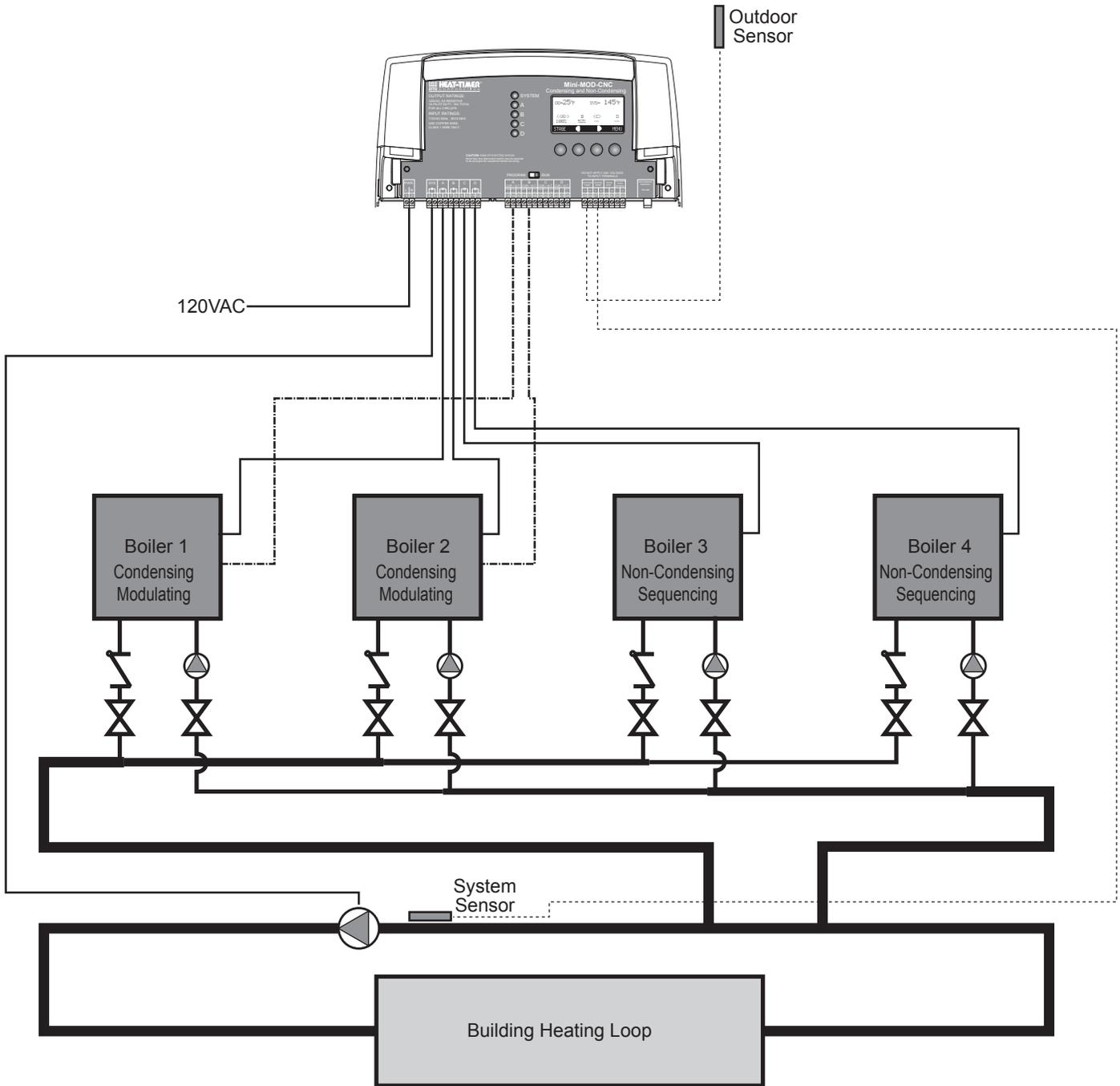

System:

The Mini-MOD-CNC operates 2 modulating boilers and 2 On/Off Boilers. The boilers are piped in Reverse Return on the primary loop. The System output is controlling the System Pump.

Heat-Timer Corp. is aware that each installation is unique. Thus, Heat-Timer Corp. is not responsible for any installation related to any electrical or plumbing diagram generated by Heat-Timer Corp. . The provided illustrations are to demonstrate Heat-Timer Corp. 's control operating concept only.

MODULATING AND SEQUENCING BOILERS DIRECT HEATING WIRING DIAGRAM

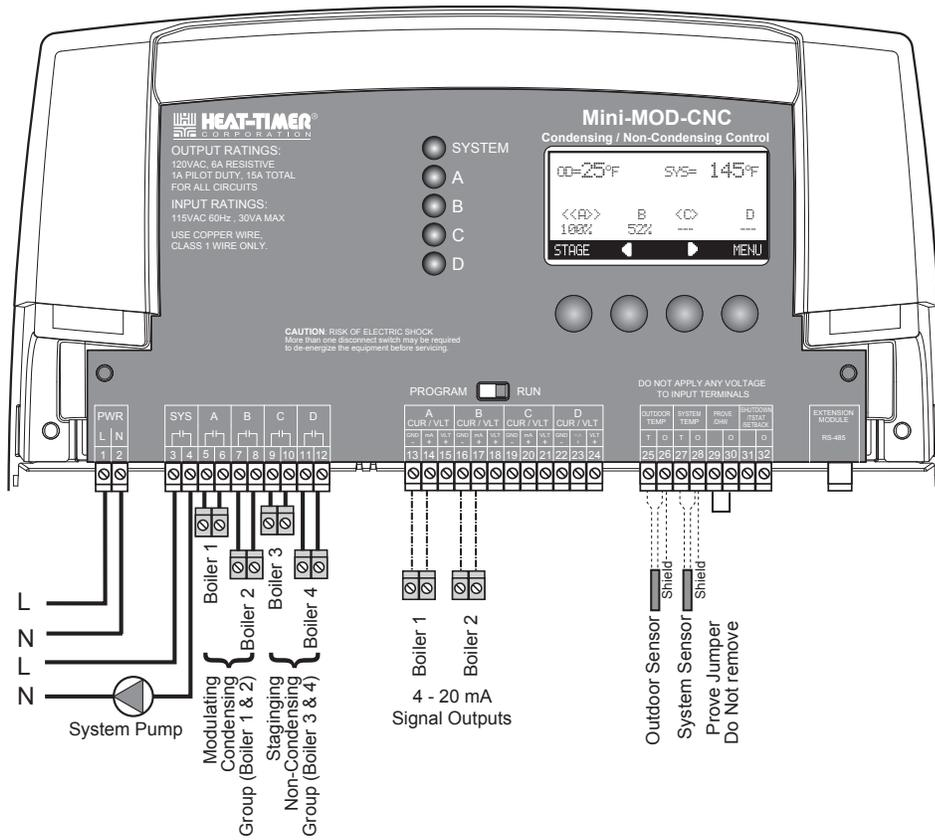

**Two 4-20mA Modulating
Condensing Boilers
and Two On/Off Non-
Condensing Boilers**

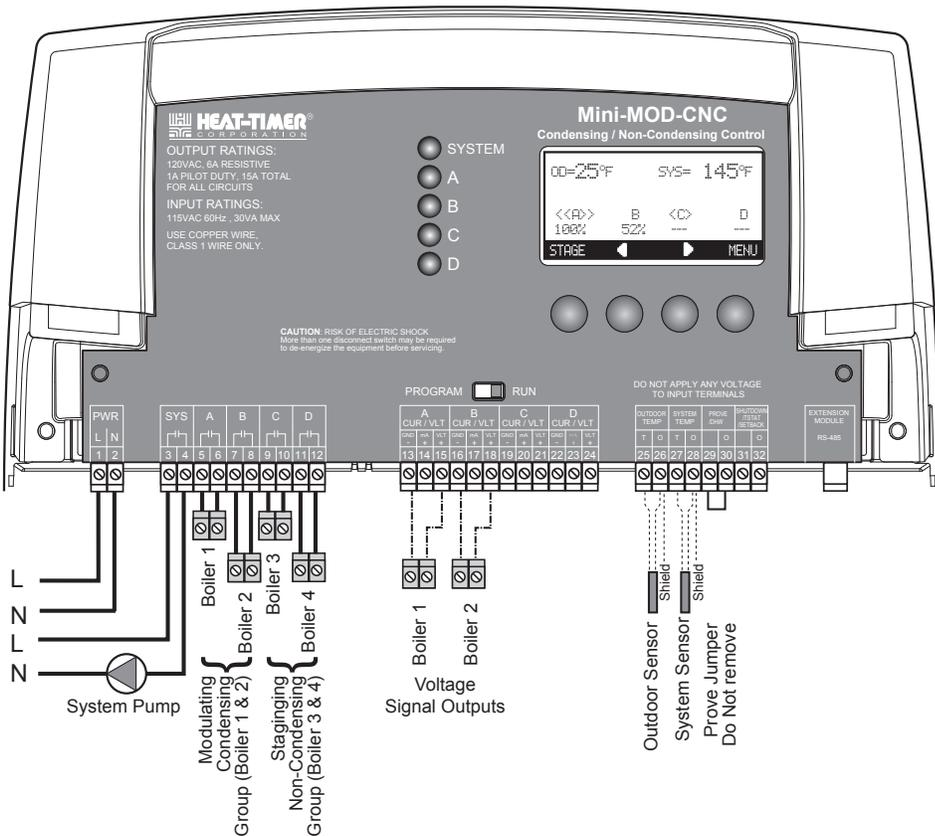

**Two Voltage Modulating
Condensing Boilers
and Two On/Off Non-
Condensing Boilers**

WARRANTY

WARRANTIES AND LIMITATIONS OF LIABILITY AND DAMAGE: Heat-Timer Corporation warrants that it will replace, or at its option, repair any Heat-Timer Corporation manufactured product or part thereof which is found to be defective in material workmanship within one year from the date of installation only if the warranty registration has been properly filled out and returned within 30 days of the date of installation. Damages to the product or part thereof due to misuse, abuse, improper installation by others or caused by power failure, power surges, fire, flood or lightning are not covered by this warranty. Any service, repairs, modifications or alterations to the product not expressly authorized by Heat-Timer Corporation will invalidate the warranty. Batteries are not included in this warranty. This warranty applies only to the original user and is not assignable or transferable. Heat-Timer Corporation shall not be responsible for any maladjustments of any control installed by Heat-Timer Corporation. It is the users responsibility to adjust the settings of the control to provide the proper amount of heat or cooling required in the premises and for proper operation of the heating or cooling system. Heat-Timer Corporation shall not be required to make any changes to any building systems, including but not limited to the heating system, boilers or electrical power system, that is required for proper operation of any controls or other equipment installed by Heat-Timer Corporation or any contractor. Third Party products and services are not covered by this Heat-Timer Corporation warranty and Heat-Timer Corporation makes no representations or warranties on behalf of such third parties. Any warranty on such products or services is from the supplier, manufacturer, or licensor of the product or service. See separate Terms and Conditions of Internet Control Management System ("ICMS") services, including warranties and limitations of liability and damages, for ICMS services.

THE FOREGOING IS IN LIEU OF ALL OTHER WARRANTIES, EXPRESS OR IMPLIED AND HEAT-TIMER CORPORATION SPECIFICALLY DISCLAIMS ANY AND ALL WARRANTIES OF MERCHANTABILITY FOR A PARTICULAR PURPOSE. UNDER NO CIRCUMSTANCES SHALL HEAT-TIMER CORPORATION, ITS AUTHORIZED REPRESENTATIVES, AFFILIATED OR SUBSIDIARY COMPANIES BE LIABLE FOR SPECIAL, CONSEQUENTIAL OR INCIDENTAL DAMAGES, EXCEPT AS SPECIFICALLY STATED IN THESE TERMS AND CONDITIONS OF SALE. THE SOLE REMEDY WITH RESPECT TO ANY PRODUCT OR PART SOLD OR INSTALLED BY HEAT-TIMER CORPORATION SHALL BE LIMITED TO THE RIGHT TO REPLACEMENT OR REPAIR F.O.B. FAIRFIELD, NJ. HEAT-TIMER CORPORATION SHALL NOT BE LIABLE OR RESPONSIBLE FOR LOSS OR DAMAGE OF ANY KIND RESULTING FROM DELAY OR INABILITY TO DELIVER FOR ANY REASON, INCLUDING BUT NOT LIMITED TO FIRE, FLOOD, LIGHTNING, POWER FAILURE OR SURGES, UNAVAILABILITY OF PARTS, STRIKES OR LABOR DISPUTES, ACCIDENTS AND ACTS OF CIVIL OR MILITARY AUTHORITIES.

03122010

INDEX

B

Boost Mode 20

C

CNC Overview. 3
 Condensing 6 13 16 17 18 19 25 35 *See also* Lead Group

D

Day/Night Schedule 11 12 28 33
 DHW
 Call 12 15 19 20 22 30 33
 Priority 12 15 19 20 22 30 33
 Display 30
 Boiler Status 6 9 20 22 24 26 30 33
 Messages 6 9 20 22 24 26 30 33
 Domestic Hot Water 12 19 33 *See Also* DHW

E

Enclosure
 Mounting 9
 Extension
 Connecting 14

F

Factory Defaults 20
 Fault
 Sensor 6 13 16 17 18 19 25 35

G

Gain 10 21 26 33
 group
 Condensing 3 6 16 17 19 25 30
 Lag 3 15 16 17 21 22 28 29 31 40
 Lead. 3 15 16 17 21 22 24 28 29 31 40
 Non-Condensing 3 6 16 17 19 25 30 31

H

Heavy Load 17
 History 28

I

Ignition. 26 31 32
 Installation
 Enclosure *See* Mounting Enclosure
 Outdoor Sensor 10
 System Sensor 10

L

Lag Boiler 25
 Lag Delay 18 21 26 30 32 33
 Lag Group 3
 Last Stage Hold 25 30 33
 Lead Boiler
 Rotation 25
 Lead Group 3 16 17 25
 Lead Stage 25 30 33

M

Menu
 Operating 21
 Startup 15
 Messages
 Display 6 13 16 17 18 19 25 35
 Minimum Runtime 21 27 33
 Modulating Mode 18
 Modulation Start 18 26 32

N

Non-Condensing 3 6 13 16 17 18 19 25 *See also* Lead Group

O

Offset 6 7 8 22 23 33
 Outdoor
 Sensor 6 13 16 17 18 19 25 35
 Outdoor Cutoff 6 7 11 12 19 20 22 23 24 31
 Outdoor Reset 6 7
 Outdoor:Water 7

P

Piping 34
 Purge Delay 21 24 31

R

Reaction Time 21 27
 Reset Ratio 7 8 22 23 33

S

Schedule 28 *See also* Day / Night Schedule
 Setback 28
 Season 22
 Sensor
 Outdoor Sensor Installation 10
 Sensor Fault 20 33
 System Sensor Installation 10
 Setback 8 11 12 15 19 20 21 24 26 28 31 33
 Schedule 28
 Shutdown 8 11 12 15 19 20 24 28 31 33
 Soft-Off Delay 26

Staging Mode 19

Standby 25 26 27 30 33

Switch

 Delay 3 15 16 17 21 22 28 29 31 40

 Differential 3 15 16 17 21 22 28 29 31 40

 Mode 3 15 16 17 21 22 28 29 31 40

 Set Point. 3 15 16 17 21 22 28 29 31 40

System

 Output. 19 23 31

 Relay 19 31

System Run-On 8 12 19 21 24 25 31

T

Tstat 8 11 12 15 19 20 24 28 31 33

W

Water Temp

 Maximum 7 23 27

 Minimum 7 23 27

Wiring

 DHW 9 11 12 13 15 16 21 22 28

 Modulating Boilers 9 11 12 13 15 16 21 22 24 28 31

 Multi-Stage Boiler 13 35

 On/Off Boilers 9 11 12 13 15 16 21 22 28

 Outdoor Sensor 11

 Power 9 11 12 13 15 16 21 22 28

 Prove 9 11 12 13 15 16 21 22 28

 Shutdown 9 11 12 13 15 16 21 22 28

 System Output 9 11 12 13 15 16 21 22 28

 System Sensor 11

 Tstat 9 11 12 13 15 16 21 22 28

SPECIFICATIONS

Voltage Input:	120 VAC 60 Hz
Power Consumption:	12 VA Max
Operating Temperature:	20°F/-6°C to 130°F/54°C
Operating Humidity:	20% to 80% non-condensing
Dimensions:	11"W x 9" H x 3 3/4" D
Weight:	2.5 pounds

MINI-MOD-CNC SPECIFICATIONS

Switch Between Boiler Groups:	Target Temperature
Lead Stage Rotation:	Time (1 to 1440 Hours (60 days)), Manual, Last-On
Pump Output:	1 N.O. S.P.S.T
Modulating Boiler Modes:	Auto, Manual, Standby, On, Off
Staging Boiler Modes:	Auto, Standby, On, Off
Standby Time:	1 to 60 minutes
Modulating Output Types:	4-20mA, 0-5V, 0-10V, 1-5V, 2-10V
Sequencing Output Types:	On/Off, 2-Stage, 3-Stage, or 4-Stage
Output Relay Ratings:	1 Amp inductive, 6Amp resistive at 120 VAC 60 Hz, 15A total for all circuits
Add-On Mini-Extension Panels:	up two Mini-Extension Panels using RS485
Ignition Point %:	1 to 50%
Modulation Start Point %:	0 to 100%
Modulation Modes:	Normal or Parallel
Sequencing Modes:	Lo/Hi/Lo/Hi or Lo/lo/Hi/Hi
Temperature Display:	Fahrenheit or Celsius
Display:	Graphical Alphanumeric (up to 7 rows x 21 char. each)
LED:	1 System Output relay, 4 Boiler Output relays
Sensor Ranges:	Outdoor temperature sensor - minus 35°F/-37°C to 250°F/121°C Heating system sensor - minus 35°F/-37°C to 250°F/121°C
Outdoor Cutoff Range:	20°F/-6°C to 100°F, ON and OFF
Reset Ratio Range:	(1:4) to (4:1) (Outdoor : System Water)
Offset Adjustment:	minus -50F°/-28C° to plus 50F°/28C°
Minimum Water Temperature:	70°F/21°C to 170°F/77°C
Maximum Water Temperature:	90°F/32°C to 240°F/116°C
Domestic Hot Water:	with Priority or without Priority
Pump Run-On:	0 to 360 minutes
Purge Delay:	.0.0 to 10.0 minutes
Lag Delay:	.0 to 60 minutes
Last Stage Hold:	.0 to 30°F
Schedules:	1 Day and 1 Night (Setback) setting per day
Night Setback:	0F°/0C° to 75F°/42C°
Power Backup:	Lithium coin battery, 100 days minimum 5 year replacement (Maintains Clock in power outages)
External Inputs:	Shutdown, Tstat, and Setback Input, and Prove and DHW Call Input. (Dry Contacts Only)
Season:	Winter and Summer

MINI-EXTENSION SPECIFICATIONS

(Each Mini-Extension can add up to (6) additional modulating boilers. A maximum of two Mini-Extensions can be added to a single Mini-MOD-CNC.)

Extension Numbering:	Toggle Switch A (Stages E - J, LEDs are Green) or B (Stages K - P, LEDs are Red)
Boiler Outputs:	(6) N.O. S.P.S.T.
Modulating Output Types:	(6) 4-20mA, 0-5V, 0-10V, 1-5V, 2-10V
Output Relay Ratings:	1 Amp inductive (1/8HP), 6Amp resistive at 120 VAC 60 Hz, 15A total for all circuits
Connection to Mini-MOD-CNC and another extension:	Two RS485 connections using phone style cable (Cable is provided)

HT# 059102-00 B

