



TAV SERIES

THERMOSTATIC AIR VENT

Pressures To 650 PSIG (44.8 barg)
Temperatures to 750°F (400°C)

Sealed Stainless Steel Body — Lightweight, compact and corrosion resistant. No bolts or gaskets. Eliminates body leaks.

Self Centering Valve — Leak tight shutoff. Improved energy savings. Assembly of actuator and valve to impingement plate allows valve to self-align with center of valve seat orifice. Provides long lasting valve and seat.

Temperature Sensitive Actuators — One moving part. Stainless Steel, fail open, welded actuator for maximum corrosion, thermal and hydraulic shock resistance.

Thermal and Hydraulic Shock Resistant — Impingement plate plus welded construction prevent damage to actuator.

Hardened Stainless Steel Valve and Seat — Long life. Lapped as a matched set for steam tight seal.

Inexpensive — Low initial cost.

Maintenance Free — Sealed unit. Replacement traps cost less than repair of more expensive in-line repairable vents.

Directional Discharge — Pipe thread erosion prevented by directing discharge to center of pipe.

Guaranteed — Guaranteed for 3 years against defects in materials or workmanship.

MODELS

- TAV—High capacity w/welded SS actuator

APPLICATIONS

- Platen Presses
- Plating Tanks
- Sterilizers
- Tire Presses
- Cooking Equipment
- Laundry Equipment
- Other Process Equipment

Canadian Registration # OE0591.9C

OPERATION

Thermal actuator is filled at it's free length with a liquid having a lower boiling point than water. As assembled, valve is normally open. On startup, air passes through vent. As air is eliminated, hot steam reaches vent and the thermal actuator fill vaporizes to a pressure higher than line pressure. This forces

valve into seat orifice to prevent any further flow. Should more air collect, it takes heat from the actuator, lowering internal pressure. Line pressure will then compress thermal actuator to open valve and discharge air. Valve lift automatically adjusts to variations.

TAV SERIES THERMOSTATIC AIR VENT

SPECIFICATION

Air vent shall be of balanced pressure design stainless steel welded actuator capable of discharging air within 35°F of saturated temperature. Thermostatic actuator shall employ a conical valve lapped in matched sets with the seat ring assuring tight shut off. Vent shall be stainless steel bodied suitable for pressures to 650 psig and available in 3/8" through 1" NPT or socketweld.

MAXIMUM OPERATING CONDITIONS

PMO: Max. Operating Pressure	650 psig	(44.8 barg)
TMO: Max. Operating Temperature	650°F	(343°C)
PMA: Max. Allowable Pressure	650 psig	(44.8 barg)
TMA: Max. Allowable Temperature	750°F	(400°C)

MATERIALS OF CONSTRUCTION

Body & Cover:.....ASTM A351 Grade CF3M (316L)
Actuator:Welded Stainless Steel
Valve & Seat:.....Hardened 416 Stainless Steel

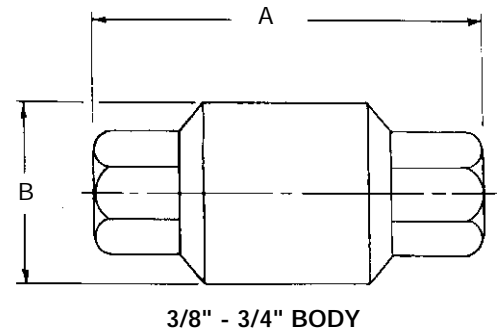

3/8" - 3/4" BODY

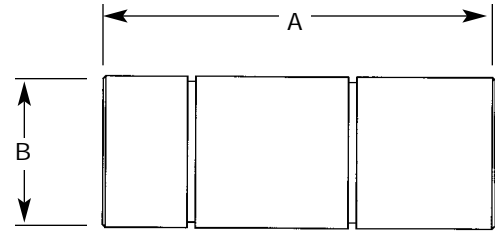

1" BODY

Connections:
3/8" – 1" NPT or socketweld

NPT or Socket weld	Dimensions		Weight Lbs. (kg)
	inches (mm)		
	A	B	
3/8, 1/2"	3 ³ / ₄ (95)	1 ³ / ₄ (44)	1.1 (0.5)
3/4"	3 ¹⁵ / ₁₆ (100)	1 ³ / ₄ (44)	1.2 (0.54)
1"	4 ³ / ₈ (111)	1 ³ / ₄ (44)	1.6 (0.73)

Air Capacity—SCFM for 14.7 PSIA @ 60°F (dm ³ /s)																
Vent	Orifice Inch (mm)	Inlet Pressure (barg)														
		10 (0.7)	50 (3.5)	100 (6.9)	125 (8.62)	150 (10.3)	200 (13.8)	250 (17.2)	300 (20.7)	350 (24.1)	400 (27.6)	450 (31.0)	500 (34.5)	550 (37.9)	600 (41.4)	650 (44.8)
TAV	5/16 (8)	33 (16)	34 (20)	156 (74)	192 (91)	230 (109)	300 (142)	370 (175)	440 (208)	510 (241)	580 (274)	650 (307)	720 (340)	790 (373)	860 (406)	930 (439)

TAV THERMOSTATIC
AIR VENT