

# HEAT-TIMER®

## INSTALLATION AND OPERATION INSTRUCTIONS

### DiGi-SPAN® *Elite Series*

# TSC DIGI-ELITE Two-Stage Set Point Control

Temp	-30°F - 250°F (-34°C-121°C)	Pressure	0 PSI - 30 PSI	Pressure	0.0 MPa - 0.250MPa
Humidity	0% RH - 100% RH		0 PSI - 100 PS		0.0 MPa - 0.600MPa
Vacuum	0 Hg - 30 Hg 0mm - 760mm		0 PSI - 200 PSI		0.0 MPa - 1.000MPa
			0 PSI - 300 PSI		0.0 MPa - 1.600MPa

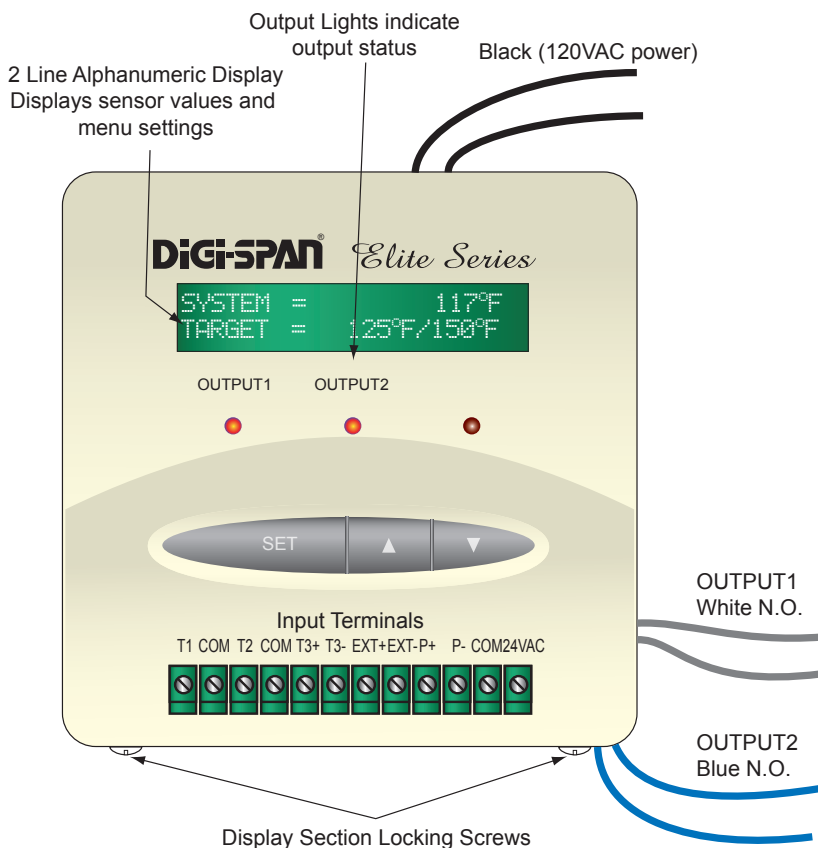

The TSC Elite is a microprocessor based Two-Stage set point control that provides users with Digital Set Point capability to measure and control two-stage heating, cooling, or change-over (Heat/Cool) devices based on a remote temperature, pressure, vacuum, or humidity sensor Input. With built-in two Output relays, it is capable of activating or deactivating equipment and devices based on the two set points and differential.

Some features that are incorporated into the TSC Elite include:

- Sensor Fault Output Status.
- Enable/Disable Terminals.
- Sensor Trim to calibrate sensor.
- Independent or consecutive operating mode.
- Back-lit 2-Line Alpha-Numeric LCD Display.
- Vacuum sensor reading
- English and Metric scales.

### **WARNING**

This Heat-Timer control is strictly an operating control; it should never be used as a primary limit or safety control. All equipment must have its own certified limit and safety controls required by local codes. The installer must verify proper operation and correct any safety problems prior to the installation of this Heat-Timer control.

### LIMITED ONE-YEAR WARRANTY

This Heat-Timer device was thoroughly tested for defects and workmanship before leaving our factory. We do warrant the equipment to be free of defects under normal use for a period of one year from the date of installation. Transportation charges for factory repairs must be prepaid. Damage to the Heat-Timer device or any of its components due to misuse, abuse, improper installation, or caused by power failures, fire, flood, or lightning are not covered by this warranty. The company assumes no liability for indirect or consequential damages of any nature. This Heat-Timer warranty applies only to the original purchaser/user, is not assignable or transferable, and does not cover damage to the device occurring in shipment. Any service, repairs, modifications or alterations to the unit not expressly authorized by the company will invalidate the warranty. This warranty is in lieu of all other warranties expressed or implied.

## Mounting the Controller

- The TSC DIGI-Elite is designed to mount on a 1900 (4"x4") electrical box.
- If the TSC-Elite is to be panel mounted, or if additional room is needed use the Plastic Wiring Enclosure (HT# 929135-00 Switch) or (HT# 929137-00 without a Switch).
- Locate the TSC-Elite in a convenient location near the unit to be controlled.
- Partially unscrew the Display Cover Mounting screws. This allows for its removal.
- Lifting the Display Section away from the base will unplug the Connection Socket from the Base section.
- Proceed with the power and output wiring instructions.
- Mount the TSC away from excessive heat or cold. Ambient operating temperature is from 20 to 120°F.
- Mount Display Section back to the Base Section. Tighten the Display Cover Mounting Screws.

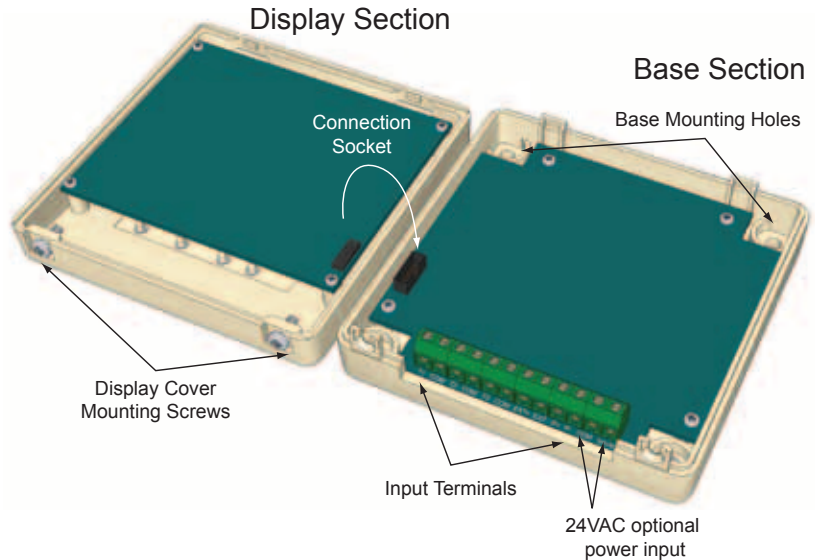

## Wiring Power Input

The TSC-Elite is designed to accept **ONLY A SINGLE POWER SOURCE**. It can be wired to either 120VAC using the two Black wires or 24VAC using the right most two terminals on the terminal block on bottom of the control. Heat-Timer recommends the installation of a Surge Suppressor and a Power Switch before the Power Line connection for safety and ease of service.

### 120VAC

- Attach line voltage, 120VAC, to the two Black wires extending from the back of the TSC-Elite. Remember to use the power line from a different source than the equipment being controlled.

### 24VAC

- Use a dedicated transformer with at least a 5VA output.
- Bring 24VAC to the two right most screws on the front of the TSC-Elite marked *24VAC* and *COM*

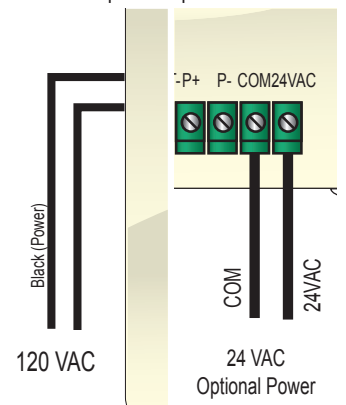

## Wire Colors

- The TSC Elite has a S.P.S.T. (single-pole single-throw N.O.) relays. Each output is rated at 6A, 1/8 HP.
- The outputs are dry contacts only. They do not source any power.
- The two White wires represent Output 1 relay.
- The two Blue wires represent Output 2 relay

### WARNING

The TSC-Elite can accept only one source of power: 120VAC or 24VAC. If more than one power source is applied, the unit may be damaged.

## Wiring Input Terminals

Based upon the options selected from the Sensor Type in Startup menu, the sensor input terminals will vary. The TSC Elite will only measure the terminals used for the specific sensor type. All other sensor terminal inputs will be ignored. i.e., if the TSC was set to measure Temperature 250°F, it will only measure terminals T1, COM. See "Sensor Type Settings and Terminals" on page 6

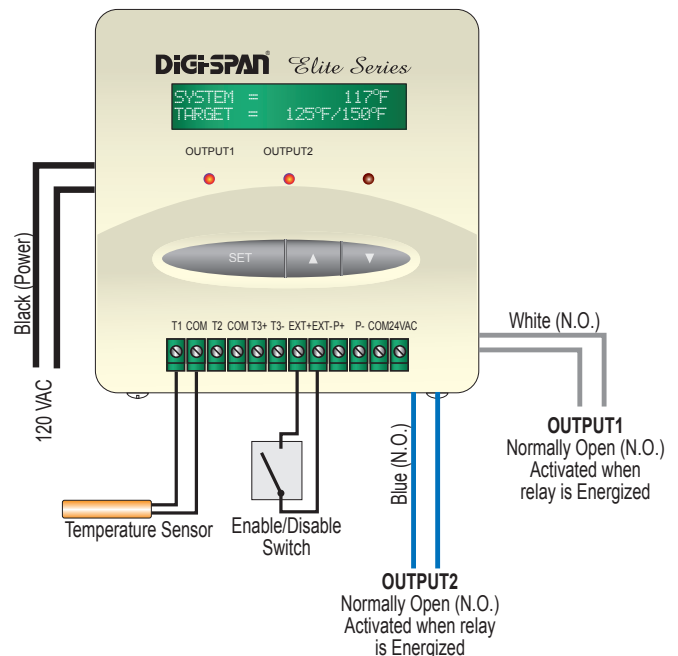
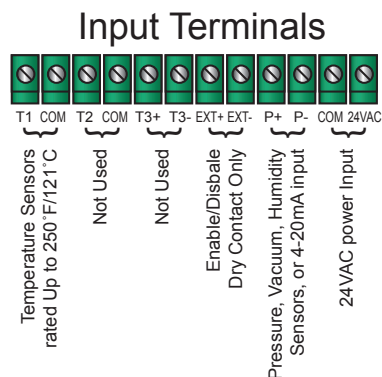

## Installing and Wiring Temperature Sensor Inputs

### (T1, COM (-30°F-250°F))

A variety of sensor inputs can be connected to the TSC-Elite series depending on the model and sensors provided. Each TSC-Elite comes with the sensors it is designed to work with.

- The sensor wires can be extended up to 500' by splicing with 18 gauge shielded wire.
- Do not run sensor wires in conduit with line voltage.
- If measuring liquid temperature, the sensor should be inserted into a 3/8" ID well (HT#904011 or equivalent).
- The TSC-Elite will operate based on the temperature it reads at the sensor location. Therefore, select a sensor location that is representative of the entire system.
- In temperature applications, polarity is not observed. Either wire from the sensor can be connected to either sensor input.
- Connect the Shield of each sensor at the control side to the respective COM terminal.

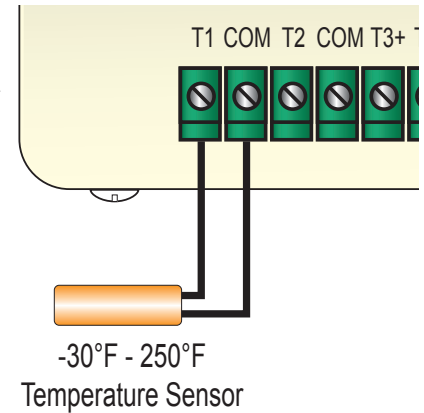

## Installing and Wiring a Pressure or Vacuum Sensor

### (P+, P-)

- Attach a 1/4" brass isolation tube (pigtail) to the steam header.
- Screw the pressure or Vacuum sensor to the pigtail. The sensor has 1/4" NPT tapered threads.
- The sensor wires can be extended up to 500' by splicing with 18 gauge shielded wire.
- Do not run sensor wires in conduit with line voltage.
- The TSC-Elite will operate based on the pressure or vacuum sensor reading. Therefore, select a sensor location that is representative of the entire system.
- The sensor's BLACK wire should be connected to the terminal marked P (-).
- The RED wire from the sensor should be connected to the terminal marked P (+).

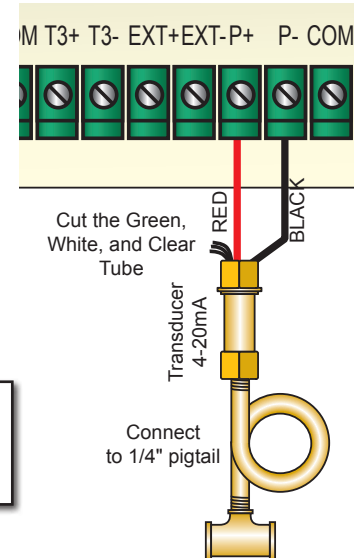

### **⚠️ ALERT**

The EXT input terminals must be shorted for TSC-Elite to operate the outputs. DO NOT remove the factory installed EXT jumper unless it is replaced with an Enable Signal.

## Connecting the Enable/Disable

### (EXT+, EXT-)

- The EXT terminals can be used to enable or disable the system by connecting it to either a thermostat or external control.
- The EXT input should be dry contact only.
- Polarity is not important. Either wire from the thermostat can be connected to either EXT terminals.
- If no thermostat or control is connected to the EXT terminals, leave the jumper supplied as a contact to the terminals.
- No outputs will be active unless the EXT terminals are closed.

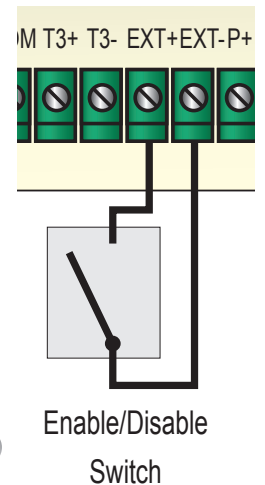

## Button and Navigating Menus

The TSC Elite has three buttons.

- The SET button function varies. When the Default Screen is displayed, pushing the SET Button views the MENU. When in the Menus and settings, the SET Button accepts the selected entry or setting value.
- When in the menus, the Up and Down buttons will scroll through the menu options. They can be used to change the setting of a specific function. i.e. change the Set Point, Differential, or System Trim.
- At the end of every operation menu there is a <Back> option that allows the user to go back one menu level. If the SET Button was held down for three seconds on the <Back> option, the display will go back to the default screen.



## Startup Options

Whenever the control is started for the first time or after a manual reset, it will initiate its operation with the Startup Menu. Moreover, the Startup menu can be accessed by selecting it from the operation menu. An option must be selected in each screen in the Startup Menu to move to the next level.

## Standard

**Options: English, Metric**

**Default: English**

: MENU/<System Startup>/Standard

Due to the large variety of inputs available to connect to the TSC Elite, this option helps in narrowing down the sensor type options.

- If English is selected, sensor types in °F (Fahrenheit), PSI (Pounds/Square inch), Hg (Inches of Mercury for Vacuum) will be available.
- If Metric is selected, sensor types in °C (Celsius), MPa (Million Pascal), mm (Millimeter of Mercury for Vacuum) will be available.
- %RH (Relative Humidity) will be available in both options.

```
STANDARD:
English
Metric
```

## Sensor Type

**Options: Temp.250°F/121°C, Pres. 30Psi/0.25MPa, Pres. 100Psi/0.60MPa, Pres. 200Psi/1.0MPa, Pres. 300Psi/1.6MPa, Vac. 30Hg/760mm, and Humidity %RH**      **Default: Temp.250°F/121°C**

: MENU/<System Startup>/Standard/Sensor Type

The Sensor Type available options depend on the Standard Option selected from the previous menu.

```
SENSOR TYPE:
Temp. 250°F
Pres. 30Psi
Pres. 100Psi
Pres. 200Psi
Pres. 300Psi
Vacuum 30in
Humidity %RH
```

```
SENSOR TYPE:
Temp. 121°C
Pres. 0.250MPaPsi
Pres. 0.600MPaPsi
Pres. 1.000MPaPsi
Pres. 1.600MPaPsi
Vacuum 760mm
Humidity %RH
```

## Control Mode

**Options: Heat-BreakOnRise, Cool-MakeOnRise, Change-over**      **Default: Heat-BreakOnRise**

**SET Button:** MENU/<System Startup>/Standard/Sensor Type/Control Mode

- In Heat-Break-On-Rise mode each relay will energize when the sensor value is below the corresponding set point.
- In Cool-Make-On-Rise mode each relay will energize when the sensor value is above the corresponding set point.
- In Change-Over mode (Heat/Cool), the first output relay will energize when sensor value is above SP1. However, when the sensor value falls below SP2, the 2nd output relay will energize.

```
CONTROL MODE:
Heat-BreakOnRise
Cool-MakeOnRise
Change-Over
```

## Operating Mode

*(Available in Heat and Cool Modes Only)*

**Options: Independent, Consecutive**

**Default: Independent**

: MENU/<System Startup>/.../Operating Mode

- If the Operating mode is set to Heating and Consecutive, Output2 relay (Blue wires) will operate from the lowest sensor temperature to the SP2 Setting. However, Output1 relay (White wires) will operate from SP2 setting to the SP1 Setting.
- In Consecutive mode, a maximum of one output will be on at any point.
- In Consecutive mode, no rotation will be available.
- Consecutive mode, is great for applications where the outputs are not equal in capacity.
- In Independent mode, both outputs could be on when below the lowest Set Point in Heating or when above the highest Set Point in Cooling.

```
OPERATING MODE:
Independent
Consecutive
```

## Sensor Fault

*(Not Available in Change-Over Mode)*

**Options: All Off, All On**

**Default: All On**

**v:** MENU/<System Startup>/.../Sensor Fault

- The Sensor Fault will determine the operating status of the relay when a sensor reads Short or Open. On sensor fault the Set Point will indicate **FAULT TGT=ON** or **OFF** to indicate the condition of the output and the Sensor will read **SYSTEM=OPEN** or **SHORT** to indicate the condition of the sensor.

```
SENSOR FAULT:
Output On
Output Off
```

```
SYSTEM= OPEN
FAULT TGT= ON
```

## Manually Resetting the Control to Defaults

To Reset the TSC Elite control to its original factory defaults, power down the control. Hold down the SET and DOWN buttons while powering the control back up until the Loading Default Values screen appears. The Display will direct you to the Startup menu after the defaults are loaded to program the control.

```
Loading Default
Values...
```

### ALERT

When resetting the control to original factory defaults all control settings will be over written and will no longer exist.

## Menus

### Startup Menu

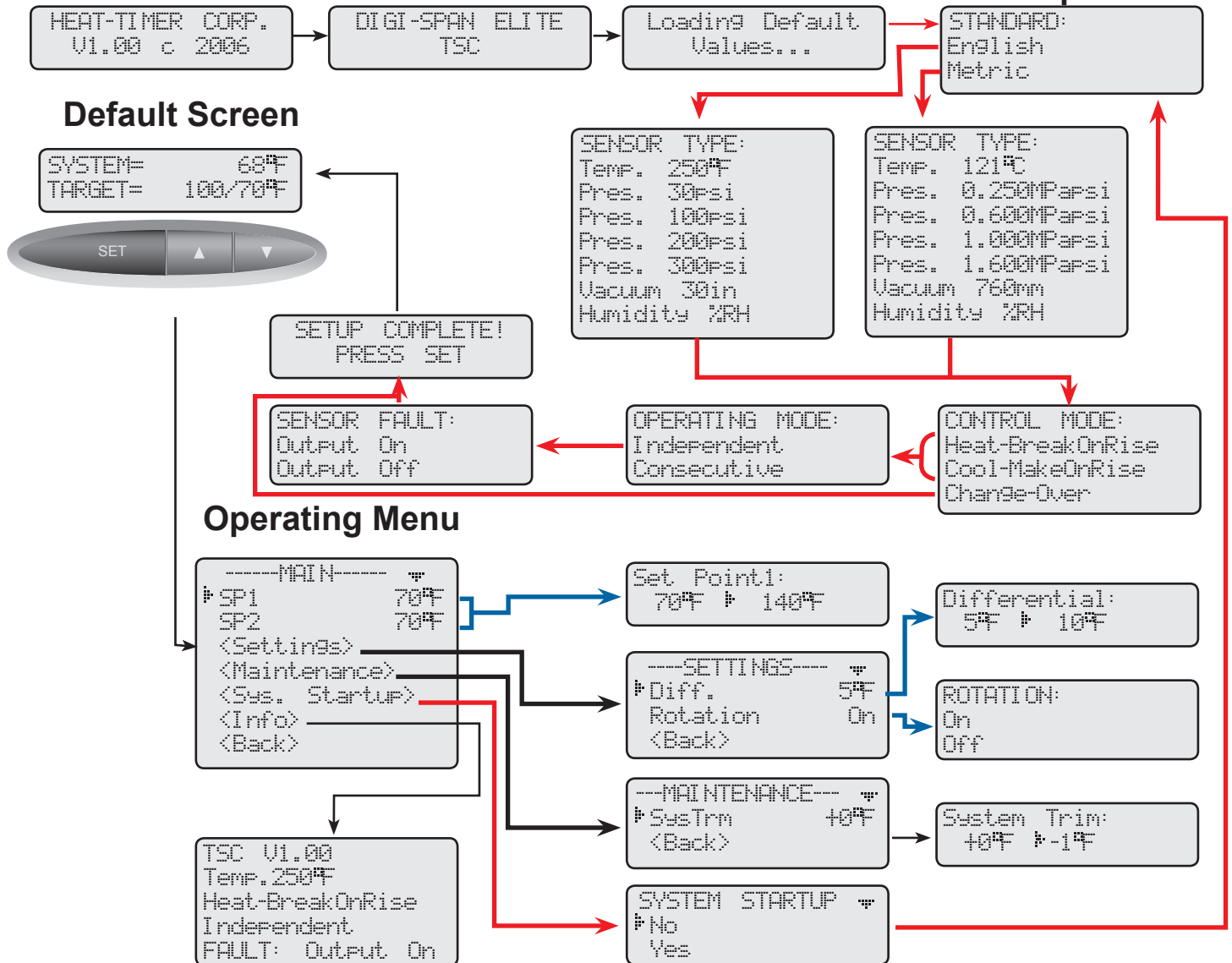

## Operating Menu Options (Click SET Button)

### Set Point SP1, SP2

**Options:** Varies based on Sensor Type. See "Sensor Type Settings and Terminals" on page 6

**SET**: MENU/SP1, SP2

- Each of the Set Points (Target) is the temperature, pressure, vacuum, or relative humidity the TSC will use to control the system by energizing the respective output relay. It will be displayed on the default screen as Target= SP1/SP2.

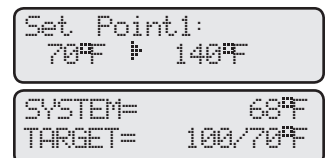

### Differential

**Options:** Varies based on Sensor Type. See "Sensor Type Settings and Terminals" on page 6

**SET**: MENU/<Settings>/Diff.

- The differential controls how many degrees the system can fluctuate around any of the set points. It is used to prevent short cycling of the unit being controlled.
- A smaller Differential setting will normally result in tighter control of the set point but will tend to increase the frequency of fluctuation in the system. Larger Differential values will reduce output short cycling, but the system will be allowed to vary further from the set point value
- Depending on the control mode of operation, the differential will be either added or subtracted from the set point.

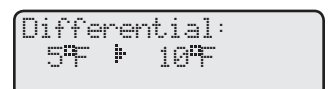

## Rotation

(Not Available in Consecutive or Change-Over Modes)

Options: On, Off

**SET**: MENU/<Settings>/Rotation.

- If Off was selected, the TSC Elite will have a fixed lead stage and no rotation will take effect.
- If On was selected, the TSC Elite will rotate the lead stage every 24 hours. When the TSC's power is turned on, the first rotation will take place in 12 hours. The 24-hour rotation will take effect after the first rotation.

```

ROTATION:
On
Off
  
```

## System Trim

Options: Varies based on Sensor Type

**SET**: MENU/<Maintenance>/SysTrm

The System Trim value adjusts the sensor reading using positive or negative values. It allows you to calibrate the sensor by the number of units selected.

```

System Trim:
+0°F -1°F
  
```

## Sensor Type Settings and Terminals

STANDARD	SENSOR TYPE	SET POINT		DIFFERENTIAL		TRIM (Default=0)	SENSOR TERMINALS
		Range	Default	Range	Default	Range	
English	Temperature 250°F	-30°F to 250°F	70°F	1°F to 40°F	5°F	-20°F to +20°F	T1, COM
English	Pressure 30 PSI	0.0 to 30.0 PSI	10.0 PSI	0.5 to 10.0 PSI	2.0 PSI	-3.0 to +3.0 PSI	P+, P-
English	Pressure 100 PSI	0 to 100 PSI	30 PSI	1 to 30 PSI	7 PSI	-10 to 10 PSI	P+, P-
English	Pressure 200 PSI	0 to 200 PSI	60 PSI	1 to 60 PSI	10 PSI	-20 to +20 PSI	P+, P-
English	Pressure 300 PSI	0 to 300 PSI	80 PSI	1 to 90 PSI	20 PSI	-30 to +30 PSI	P+, P-
English	Vacuum 30 Hg	0.0 to 30.0 Hg	10.0 Hg	0.5 to 10.0 Hg	2 Hg	-3.0 to +3.0 Hg	P+, P-
Metric	Temperature 120°C	-34°C to 121°C	21°C	1°C to 22°C	3°C	-11°C to +11°C	T1, COM
Metric	Pressure 0.250 MPa	0.0 to 0.25 MPa	0.10 MPa	0.001 to 0.100 MPa	0.02 MP	-0.025 to +0.025 MPa	P+, P-
Metric	Pressure 0.600 MPa	0.0 to 0.6 MPa	0.2 MPa	0.002 to 0.200 MPa	0.03 MPa	-0.06 to +0.06 MPa	P+, P-
Metric	Pressure 1.000 MPa	0.0 to 1.0 MPa	0.3 MPa	0.005 to 0.300 MPa	0.05 MPa	-0.1 to +0.1 MPa	P+, P-
Metric	Pressure 1.600 MPa	0.0 to 1.6 MPa	0.5 MPa	0.005 to 0.500 MPa	0.10 MPa	-0.16 to +0.16 MPa	P+, P-
Metric	Vacuum 760 mm	0 to 760 mm	250 mm	10 to 250 mm	50 mm	-80 to +80 mm	P+, P-
English / Metric	Humidity %RH	0 to 100%RH	60 %RH	1 to 30 %RH	7 %RH	+10 to -10%RH	P+, P-

## Heating, Cooling, and Change-Over (Heat/Cool) Operation

The TSC Elite can operate in either heating or cooling applications. Select the proper application from the Startup menu.

- In heating applications, the TSC Elite control will use the Set Point less the Differential as a starting point when sensor reading is dropping. Then, it will keep the relay energized as long as the sensor is below the Set Point (Target).
- When the system value increases in heating applications, the relay will remain energized until the Set Point (Target) is reached. Then, it will de-energize.

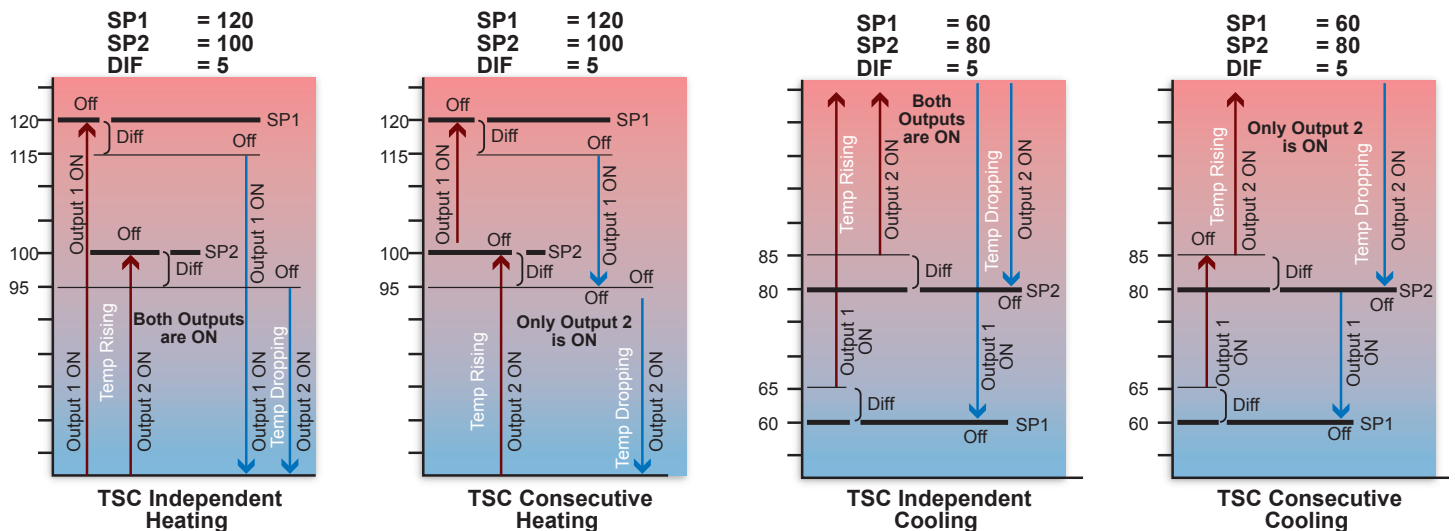

- In cooling applications, the TSC Elite control will use the Set Point plus the Differential as a starting point when sensor reading is increasing. It will energize the output relay as long as the sensor is above the Set Point (Target).
- When the system value falls in cooling applications, the relay will remain energized until the Set Point (Target) is reached. Then, it will de-energize.
- The Change-Over option will allow Output 1 relay to follow SP1. Output1 relay will energize whenever the sensor valve is above SP1 plus the differential. The relay will de-energize when the sensor value drops to the SP1 value. The Output 2 relay will follow SP2. Output2 relay will energize whenever the sensor valve is below SP2 minus the differential. The relay will de-energize when the sensor value increases to the SP2 value.

## Output Light

The TSC Elite has three lights, however, only the left two output lights are used. They follow the relay operation. Whenever, the left Output Light is ON, Output 1 is active and the relay is energized. The middle light will represent Output 2 status.

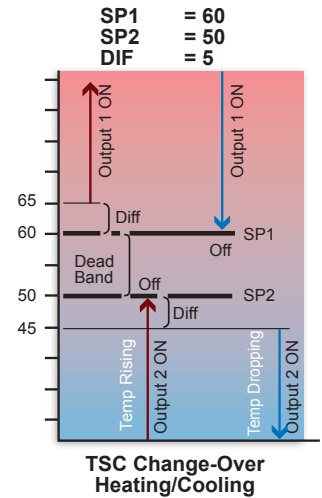
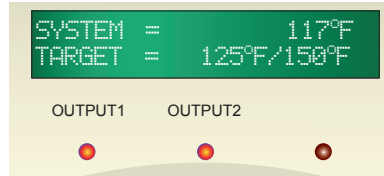

## Enable/Disable Input

The TSC Elite will operate in heating or cooling modes only if the EXT- and EXT+ terminals are shorted. If no external equipment or switch is connected to these terminals, leave the factory installed jumper. When the terminals are OPEN, the Target will display TSTAT OPEN.

**⚠️ ALERT**

On a sensor fault while the Enable/Disable terminals are open, the control will follow the Enable /Disable state. However, the System Sensor will display the fault condition weather Short or Open.

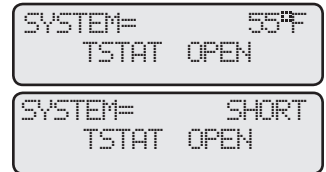

## Troubleshoot

### No Display:

Turn the power off and back on. Make sure the Display section is mounted securely to the base.

### OPEN or SHORT Display:

First, make sure that the Sensor Type selected matches the sensor used. Also, make sure that the sensor is connected to the respective input terminals. If control reads OPEN, the TSC-Elite either does not see a sensor connected or the sensor reading is below the sensor operating range. Check the sensor wires are connected from the sensor to the TSC-Elite controller. If SHORT, the TSC-Elite either sees a short across the input terminals or the sensor reading is above its operating range. Remove the sensor wires from the TSC-Elite terminals, the display should read OPEN. If the display does not change to OPEN, the TSC-Elite may be damaged. Otherwise, follow steps for Incorrect Temperature Display for temperature sensors or Incorrect pressure or Vacuum Display for all transducers.

### Incorrect Temperature Display:

Remove the wires from the SENSOR screws. The display should change to read OPEN. If it doesn't, the TSC-Elite may be damaged. For temperature, take an ohm reading across the detached sensor wires. The ohm reading should correspond to the chart on the right. If the ohm reading is significantly different, the sensor may be damaged.

**250°F/120°C Temperature Sensor Chart**

TEMPERATURE		Value (in Ohms)
°F	°C	
OPEN		150000
-30	-34	117720
-20	-29	82823
-10	-23	59076
0	-18	42683
10	-12	31215
20	-7	23089
25	-4	19939
30	-1	17264
35	2	14985
40	4	13040
45	7	11374
50	10	9944
55	13	8714
60	16	7653
70	21	5941
80	27	4649
90	32	3667

TEMPERATURE		Value (in Ohms)
°F	°C	
100	38	2914
110	43	2332
120	49	1879
130	54	1524
140	60	1243
150	66	1021
160	71	842
170	77	699
180	82	583
190	88	489
200	93	412
210	99	349
220	104	297
230	110	253
240	116	217
250	121	187
SHORT		100

**Incorrect Pressure or Vacuum Display:**

Make sure that the pressure setting selected matches the pressure transducer connected to the TSC-Elite control. If it does, then use a current multi-meter and set it to read mA and put it in series with the sensor. Match the ohm reading to the pressure table below. If current does not match the actual pressure, use the System Trim from the Maintenance Menu to correct it. If the difference is larger than the System Trim range, then the pressure or vacuum transducer is damaged. Remember that Pressure and Vacuum transducers are susceptible to static electricity. Thus, reduce excessive manual handling prior to transducer installation.

**Output Red Light does not come on at the desired temperature:**

Check the set points and differential values. In a heating application, the Red light will not come on until the sensor value drops below the set point minus the differential. In a cooling application, the Red light will not turn off until the sensor value rises above the set point plus the differential.

**TSC-Elite does not activate the output:**

First remove all connections to the White and Blue output wires. If both Outputs' Red Lights are on, the relays should be energized. Both the White wires and the Blue wires should be closed. If both Outputs' Red Lights are off, the relays should be de-energized. Both the White wires and the Blue wires should be open. If the above two conditions are met, the TSC-Elite is working normally. Check the unit the TSC-Elite is controlling.

**Pressure, Vacuum, and Humidity Sensor Chart**

Input (in mA)	0 - 30 PSI 0 - 30 Vac Range	0 - 100 PSI 0 - 100% Humidity Range	0 - 200 PSI Pressure Range	0 - 300 PSI Pressure Range
2	OPEN			
4	0	0	0	0
4.08			1	
4.16		1	2	
4.53	1			10
5.07	2			20
5.6	3	10	20	30
7.2	6	20	40	60
8.8	9	30	60	90
10.4	12	40	80	120
12	15	50	100	150
13.6	18	60	120	180
15.2	21	70	140	210
16.8	24	80	160	240
18.4	27	90	180	270
20	30	100	200	300
22	SHORT			

**Specifications**

- Voltage Input:** . . . . . 120 VAC 60 Hz(2 Black wires) /24VAC 60 Hz (24VAC terminals) (Only One Power Source)
- Power Consumption:** . . . . . 3 VA Max
- Operating Temperature:** . . . . . 20°F/-7°C to 120°F/49°C
- Operating Humidity:** . . . . . 20% to 80%
- Dimensions:** . . . . . 4"W x 4"H x 2½"
- Weight:** . . . . . 1 pound
- Outputs:** . . . . . 2 S.P.S.T (White = Output1.), (Blue = Output2.)
- Output Relay Ratings:** . . . . . 1 Amp Inductive duty, 6 Amp resistive at 120 VAC 60 Hz
- Control Modes:** . . . . . Heat (Break on Rise), Cool (Make on Rise), Change-Over (Heat/Cool)
- Operating Modes:** . . . . . Independent, Consecutive (a max of a Single Stage can be on at one time)
- Rotation Options:** . . . . . On (Every 24 Hours), Off
- Sensor Fault Operating Options:** . . . . . Output On or Output Off
- Temperature Ranges:** . . . . . from -30°F (-34°C) to 250°F (121°C)
- Pressure Ranges:** . . . . . PSI (0-30PSI, 0-100 PSI, 0-200PSI, 0-300PSI) or MPa (0.25MPa, 0.60MPa, 1MPa, 1.6MPa)
- Vacuum Ranges:** . . . . . 30Hg or 760mm
- Humidity Ranges:** . . . . . 0% to 100% RH
- Display:** . . . . . Back Lite Alphanumeric (2 rows x 16 char. each)
- LED:** . . . . . 2 representing the Output relays (Left=Output1, Middle=Output2)
- Buttons:** . . . . . 3 (Set, Up, Down)
- Enable/Disable:** . . . . . Terminals EXT+, EXT-

