

200 VACUUM BREAKER

APPLICATION:

Falling liquid levels and condensing steam can cause a vacuum that can damage a tank. The 200 Vacuum Breaker opens gradually to admit outside air to relieve the vacuum in the tank. The unit must be installed vertically with its mounting connection downward.

FEATURES:

Iron, steel, or stainless steel body; Iron, steel, or stainless steel seat; Non-asbestos or TFE disc;
 Size 2" iron with NPT or 125FLG connections,
 2" steel and stainless steel with 150 or 300FLG;
 4" through 12" iron with 125FLG,
 4" through 12" steel and stainless steel with 150 or 300FLG
 Air relief capacities to 14,280 CFM
 See What's Available Chart for Features

PRESSURE-TEMPERATURE RATINGS:

Body: Iron
 End Connection: 125THD (NPT) and 125FLG
 Disc: Non-asbestos
 Maximum Pressure: 50 PSIG
 Maximum Temperature: 300F

Body: Steel or Stainless Steel
 End Connection: 150FLG
 Disc: Non-asbestos
 Maximum Pressure: 150 PSIG
 Maximum Temperature: 500F

Body: Steel or Stainless Steel
 End Connection: 300FLG
 Disc: Non-asbestos
 Maximum Pressure: 300 PSIG
 Maximum Temperature: 500F

AIR RELIEF CAPACITIES:

Vacuum Inches Of Mercury	200 CFM OF FREE AIR ADMITTED AT 60F SIZE (IN)					
	2	4	6	8	10	12
0.75	88	352	792	1408	2200	3300
0.80	94	376	846	1504	2350	3525
0.85	106	424	934	1696	2650	3975
1.15	126	504	1128	2016	3150	4725
1.25	148	592	1332	2298	3700	5550
1.65	162	648	1458	2592	4050	6780
2.30	188	752	1692	3008	4700	7050
4.00	226	904	2034	3616	5650	8475
4.45	236	944	2124	3776	5900	8850
6.05	268	1072	2412	4288	6700	10050
6.30	276	1104	2484	4416	6900	10350
8.10	300	1200	2700	4800	7500	11250
8.65	314	1256	2826	5024	7850	11775
11.30	334	1336	3006	5344	8350	12525
12.05	348	1392	3132	5568	8700	13050
16.05	370	1480	3330	5920	9250	13875
16.65	372	1488	3348	5952	9300	13950
18.50	386	1541	3481	6189	9670	14505
19.10	381	1523	3427	6093	9520	14280

The Type 200 cannot be set to open at a particular vacuum.
 The vacuum values presented in the table are for reference only.



Stainless steel stem and non-asbestos disc assembly, Iron body with seat and brass guide, and stainless steel spring assembly shown separately

4" Iron 200

WHAT'S AVAILABLE		200					
Features	Size (IN)						
	2	4	6	8	10	12	
Body/ Seat	125 THD (NPT) IRON/ IRON	●					
	125 FLG IRON/ IRON	●	●	●	●	●	
	150 FLG STL/ STL	●	●	●	●	●	
	300 FLG STL/ STL	●	●	●	●	●	
	150 FLG ST STL/ ST STL	○	○	○	○	○	
	300 FLG ST STL/ ST STL	○	○	○	○	○	
Disc	NON-ASBESTOS	●	●	●	●	●	
	TFE (TO 200 °F)	○	○	○	○	○	
Disc- holder	STEEL		●	●	●	●	
	ST STEEL	●	○	○	○	○	
	REPLACEABLE SEAT ST STEEL	○	○	○	○	○	
	BIRDSCREEN	○	○	○	○	○	
	LIFT RINGS	○	○	○	○	○	

● STANDARD
 ○ OPTION

DIMENSIONS AND WEIGHTS :

200		VALVE SIZE IN (MM)											
		2	(50)	4	(100)	6	(150)	8	(200)	10	(250)	12	(300)
A	125THD & FLG	7-1/2	(191)	10-3/4	(273)	12-11/16	(323)	16	(407)	18-3/4	(477)	22-5/8	(575)
	150FLG	7-1/2	(191)	10-1/2	(267)	15-1/2	(394)	17-1/2	(445)	21-1/8	(537)	23	(585)
	300FLG	7-1/2	(191)	11-1/4	(286)	15-1/8	(385)	TBA		21-1/8	(537)	23-1/8	(587)
B	125THD & FLG	11-15/16	(304)	14-1/2	(369)	18-1/8	(461)	19-9/16	(497)	21-1/8	(537)	23-3/8	(594)
	150FLG	13-1/8	(334)	14-7/8	(378)	19-3/16	(488)	20-5/16	(516)	27-3/4	(705)	28-1/2	(724)
	300FLG	13-1/8	(334)	15-1/4	(388)	19-11/16	(500)	TBA		29-1/8	(740)	30-7/16	(763)
Weight (LB)	125THD & FLG	26		68		102		180		230		375	

ORDERING INFORMATION:

Vacuum Breakers with Non-Asbestos Disc

200			
WITH STANDARD TRIM (Integral Seat, Non-Asbestos Disc and Steel Discholder)			
Body Material	Size	End Connection	Part Number
IRON	2*	125FLG	020009EXX000
	2*	NPT	020009IXX000
	4	125FLG	020013EXX000
	6	125FLG	020015EXX000
	8	125FLG	020017EXX000
	10	125FLG	020019EXX007
STEEL	12	125FLG	020020EXX000
	2*	150FLG	020009GXX000
	4	150FLG	020013GXX000
	6	150FLG	020015GXX000
	8	150FLG	020017GXX000
STEEL	10	150FLG	020019GXX000
	12	150FLG	020020GXX000
	2*	300FLG	020009HXX000
	4	300FLG	020013HXX000
	6	300FLG	020015HXX000
STEEL	8	300FLG	020017HXX000
	10	300FLG	020019HXX000
	12	300FLG	020020HXX000

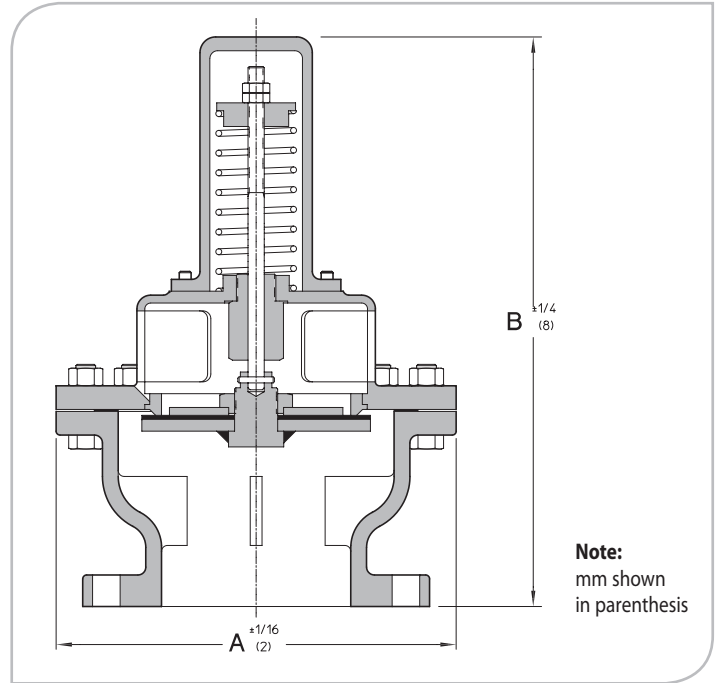

* 2" Type 200 has stainless steel discholder - standard

200			
WITH NON-ASBESTOS DISC AND STAINLESS STEEL TRIM (SS Discholder and SS Replaceable Seat)			
Body Material	Size	End Connection	Part Number
IRON	2	125FLG	020009EXX006
	2	NPT	020009IXX006
	4	125FLG	020013EXX006
	6	125FLG	020015EXX006
	8	125FLG	020017EXX006
	10	125FLG	020019EXX010
STEEL	12	125FLG	020020EXX006
	2	150FLG	020009GXX006
	4	150FLG	020013GXX006
	6	150FLG	020015GXX006
	8	150FLG	020017GXX006
STEEL	10	150FLG	020019GXX006
	12	150FLG	020020GXX006
	2	300FLG	020009HXX006
	4	300FLG	020013HXX006
	6	300FLG	020015HXX006
STEEL	8	300FLG	020017HXX006
	10	300FLG	020019HXX006
	12	300FLG	020020HXX006

200 VACUUM BREAKER

ORDERING INFORMATION:

Vacuum Breakers with Teflon Disc

200			
WITH INTEGRAL SEAT, TEFLON DISC, AND STEEL DISCHOLDER			
Body Material	Size	End Connection	Part Number
IRON	2*	125FLG	020009EXX001
	2*	NPT	020009IXX001
	4	125FLG	020013EXX001
	6	125FLG	020015EXX001
	8	125FLG	020017EXX001
	10	125FLG	020019EXX008
STEEL	12	125FLG	020020EXX001
	2*	150FLG	020009GXX001
	4	150FLG	020013GXX001
	6	150FLG	020015GXX001
	8	150FLG	020017GXX001
	10	150FLG	020019GXX001
STEEL	12	150FLG	020020GXX001
	2*	300FLG	020009HXX001
	4	300FLG	020013HXX001
	6	300FLG	020015HXX001
	8	300FLG	020017HXX001
	10	300FLG	020019HXX001
STEEL	12	300FLG	020020HXX001

* 2" Type 200 has stainless steel discholder - standard

200			
WITH TEFLON DISC, AND STAINLESS STEEL TRIM (SS Discholder and SS Replaceable Seat)			
Body Material	Size	End Connection	Part Number
IRON	2	125FLG	020009EXX004
	2	NPT	020009IXX004
	4	125FLG	020013EXX004
	6	125FLG	020015EXX004
	8	125FLG	020017EXX004
	10	125FLG	020019EXX009
STEEL	12	125FLG	020020EXX004
	2	150FLG	020009GXX004
	4	150FLG	020013GXX004
	6	150FLG	020015GXX004
	8	150FLG	020017GXX004
	10	150FLG	020019GXX004
STEEL	12	150FLG	020020GXX004
	2	300FLG	020009HXX004
	4	300FLG	020013HXX004
	6	300FLG	020015HXX004
	8	300FLG	020017HXX004
	10	300FLG	020019HXX004
STEEL	12	300FLG	020020HXX004