

FTN SERIES FLOAT & THERMOSTATIC STEAM TRAPS

Pressures To 125 PSIG (8.6 barg)
Temperatures to 450°F (232°C)



Universal Four-port Design — Four possible hookup combinations of the “H” pattern body and piping dimensions similar to other major manufacturers allow maximum installation flexibility for easy replacement of other traps. Inlet and outlet taps on larger sized traps located in the cover to permit larger capacities.

All Stainless Steel Internal Components — Hardened valves and seats. Extra long life and dependable service. Resists water hammer. Protects against erosion and corrosion.

Balanced Pressure Thermostatic Element — allows venting of non-condensibles while operating at design pressure.

Rugged Welded Stainless Steel Element — Increases service life.

Wide Selection of Differential Pressures — Sizes 3/4" to 2" available with 15, 30, 75 and 125 psig differential pressures.

Air Line Water Removal — Special configuration FTNA optimized for compressed air service.

Repairable In-line — Can be serviced without disturbing system piping.

MODELS

- **FTN-15**—Steam pressures to 15 PSIG
- **FTN-30**—Steam pressures to 30 PSIG
- **FTN-75**—Steam pressures to 75 PSIG
- **FTN-125**—Steam pressures to 125 PSIG
- **FTNA-75**—Air pressures to 75 PSIG
- **FTNA-125**—Air pressures to 125 PSIG

APPLICATIONS

- Unit Heaters & other Space Heating Equipment
- Heat Exchangers/Reboilers
- Steam Heating Coils
- Steam Main Drips
- Air Compressor Receivers
- Air Line Drips
- Air Powered Process Equipment

OPTIONS See page 9

- Repair Kits

Installation Tip: Always install STV Test & Block Valve as part of trap station
SEE PAGE 118

Installation Tip: Add Uniflex Pipe Coupling for ease of maintenance
SEE PAGE 102

OPERATION

Air entering trap is immediately discharged through the high capacity integral air vent. The thermostatic vent will close just prior to saturation temperature. The balanced design will allow venting of non-condensibles that collect in the float chamber when operating at design pressure. When steam enters the trap, the thermostatic air vent

closes to prevent steam loss. When steam gives up it's latent heat, it becomes condensate. This “condensate” enters the trap and causes the stainless steel ball float to rise. Raising of the float opens the discharge valve, allowing condensate to be continuously discharged as it enters the trap. The condensate level in the trap body is maintained above the discharge seat, providing a positive seal against the loss of steam.

FTN SERIES FLOAT & THERMOSTATIC STEAM TRAPS

SPECIFICATION

Steam trap shall be of float and thermostatic design. Float shall actuate the valve via a hinged lever and linkage. Air vent shall be of balanced pressure design with stainless steel welded encapsulated bellows capable of discharging air and noncondensable gases continuously within 15°F of saturated temperature. Traps through 1-1/4" shall employ "H" pattern connections to accommodate multiple piping configurations. Trap shall be cast iron bodied suitable for pressures to 125 psi and available in 3/4" through 2" NPT.

MAXIMUM OPERATING CONDITIONS

PMO: Max. Operating Pressure

ORIFICE	PMO	
15	15 psig	(1.03 barg)
30	30 psig	(2.07 barg)
75	75 psig	(5.17 barg)
125	125 psig	(8.62 barg)

PMA: Max. Allowable Pressure

250 psig (17.2 barg)

TMA: Max. Allowable Temperature

450°F (232°C)

MATERIALS OF CONSTRUCTION

Body & Cover . . . Cast Iron ASTMA126B

All Internal Stainless Steel

Air Vent (FTN only) Balanced Pressure,
Welded Stainless Steel

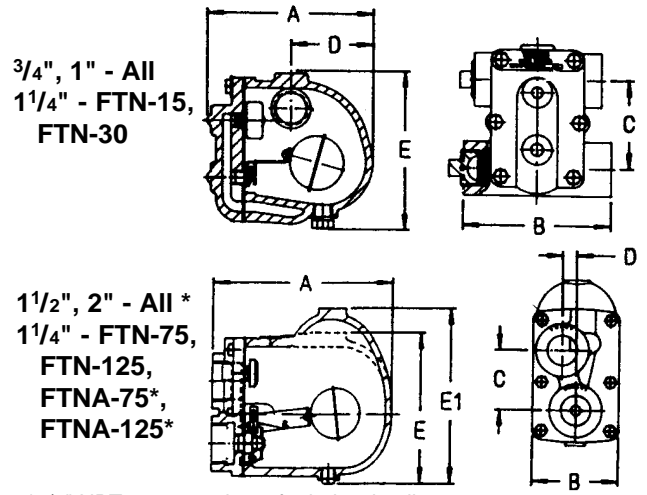

*1/8" NPT tap at top boss for balancing line.

Connections: 3/4"-2" NPT

Dimensions		Inches (mm)						Weight lbs (kg)
		A	B	C	D	E	E1	
Model No. FTN-15, FTN-30	3/4	6.25 (159)	5.50 (140)	3.31 (84)	3.00 (76)	5.75 (146)	—	9 (4.1)
	1	6.25 (159)	5.50 (140)	3.31 (84)	3.00 (76)	5.75 (146)	—	9 (4.1)
	1 1/4	6.25 (159)	5.75 (146)	3.00 (76)	3.81 (97)	5.75 (146)	—	9 1/2 (4.3)
	1 1/2	8.50 (216)	4.25 (108)	3.00 (76)	0.70 (18)	—	8.40 (213)	18 (8.2)
	2	9.81 (249)	4.94 (123)	4.94 (123)	0.12 (3)	9.12 (232)	—	26 (11.8)
Model No. FTN-75, FTN-125 FTNA-75, FTNA-125	3/4	6.25 (159)	5.50 (140)	3.31 (84)	3.00 (76)	5.75 (146)	—	9 (4.1)
	1	6.25 (159)	5.50 (140)	3.31 (84)	3.00 (76)	5.75 (146)	—	9 (4.1)
	1 1/4	8.50 (216)	4.25 (108)	3.00 (76)	0.70 (18)	—	8.40 (213)	18 (8.2)
	1 1/2	8.50 (216)	4.25 (108)	3.00 (76)	0.70 (18)	—	8.40 (213)	18 (8.2)
	2	9.81 (249)	4.94 (123)	4.94 (123)	0.12 (3)	9.12 (232)	—	26 (11.8)

Maximum Capacity—lbs/hr (10°F Below Saturation)																	
Trap	Size NPT	Orifice (in.)	Differential—PSIG (barg)														
			1/4 (.017)	1/2 (.034)	1 (.069)	2 (.138)	5 (.345)	10 (.690)	15 (1.03)	20 (1.38)	25 (1.72)	30 (2.07)	40 (2.76)	50 (3.45)	75 (5.17)	100 (6.90)	125 (8.62)
FTN-15	3/4"	.218	279	369	489	650	785	1000	1075								
FTN-15	1"	.218	279	369	489	650	785	1000	1075								
FTN-15	1 1/4"	.312	600	770	980	1240	1640	2000	2340								
FTN-15	1 1/2"	.500	1100	1700	2400	3300	5000	6600	7600								
FTN-15	2"	.625	2300	2800	3600	4650	6900	9000	10900								
FTN-30	3/4"	.218	279	369	489	650	785	1000	1075	1210	1300	1370					
FTN-30	1"	.218	279	369	489	650	785	1000	1075	1210	1300	1370					
FTN-30	1 1/4"	.228	375	500	690	910	1200	1500	1680	1800	1900	2000					
FTN-30	1 1/2"	.390	1000	1300	1700	2300	3400	4600	5500	6000	6600	7000					
FTN-30	2"	.500	1300	1800	2500	3400	5200	6800	7800	8600	9300	10000					
FTN-75 [†]	3/4"	.166	160	213	280	365	520	700	795	875	930	970	1120	1230	1450		
FTN-75 [†]	1"	.166	160	213	280	365	520	700	795	875	930	970	1120	1230	1450		
FTN-75 [†]	1 1/4"	.312	550	725	960	1300	1900	2650	3050	3400	3700	4000	4400	4750	5400		
FTN-75 [†]	1 1/2"	.312	550	725	960	1300	1900	2650	3050	3400	3700	4000	4400	4750	5400		
FTN-75 [†]	2"	.421	850	1100	1500	2000	3100	4150	4750	5200	5500	5800	6400	6800	7700		
FTN-125 [†]	3/4"	.125	100	135	175	230	330	415	500	585	620	685	750	830	970	1110	1190
FTN-125 [†]	1"	.125	100	135	175	230	330	415	500	585	620	685	750	830	970	1110	1190
FTN-125 [†]	1 1/4"	.246	400	520	680	890	1300	1700	2050	2300	2500	2700	3000	3200	3800	4200	4500
FTN-125 [†]	1 1/2"	.246	400	520	680	890	1300	1700	2050	2300	2500	2700	3000	3200	3800	4200	4500
FTN-125 [†]	2"	.332	550	675	880	1225	1950	2600	3000	3250	3500	3800	4200	4600	5500	6100	6600

For Kg/Hr Multiply by .454 †For FTNA capacities, multiply by 1.33.