

HEAT-TIMER®

- INSTALLATION AND OPERATION INSTRUCTIONS MANUAL
- USER OPERATIONS MANUAL

SQ-Elite-8T & SQ-Elite-EXT HYDRONIC SEQUENCING CONTROL

FOR HYDRONIC SYSTEMS

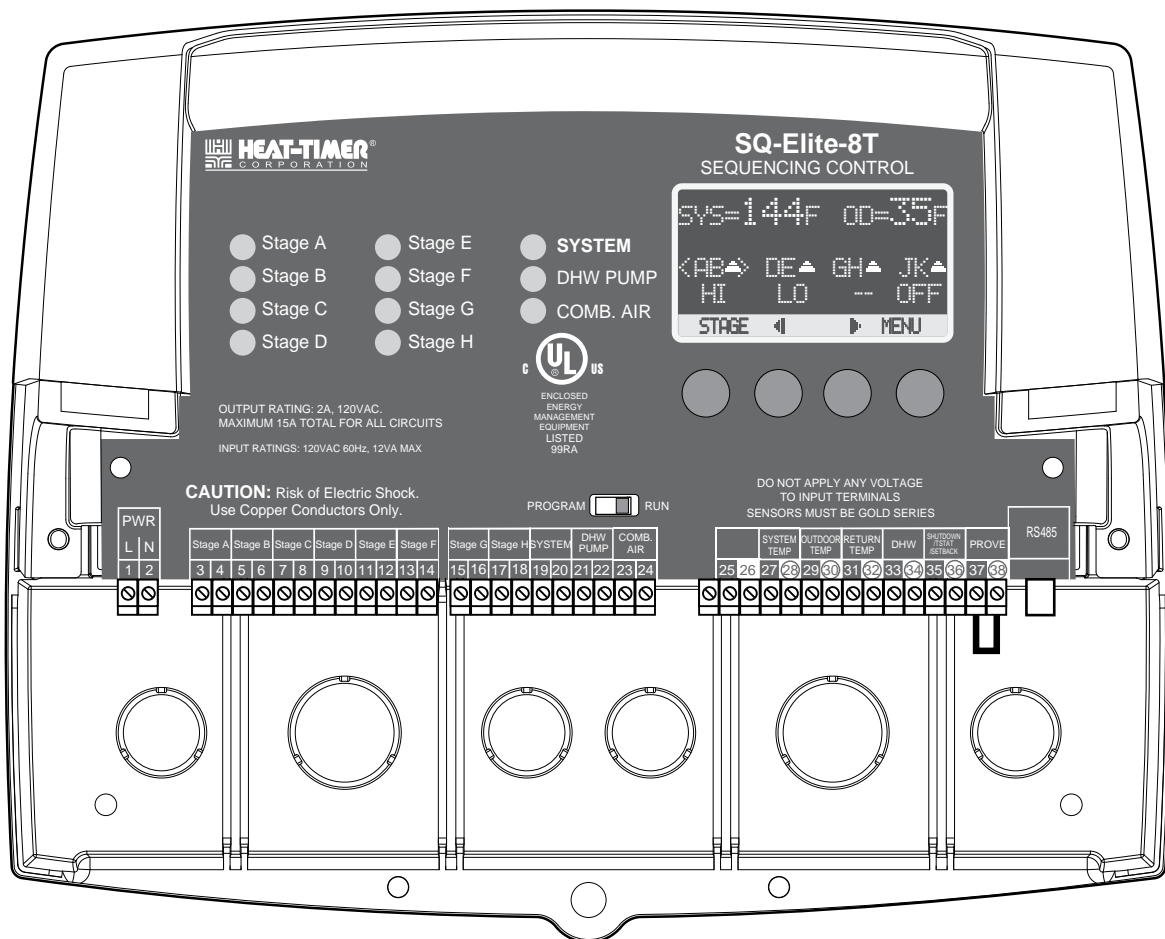

⚠ WARNING

The SQ-Elite is strictly an operating control. It CANNOT be used as a limit control. All boilers must have all safety and limit controls required by code. It is the responsibility of the installer to verify that all the safety and limits are working properly before the SQ-Elite is installed.

This control must be installed by a licensed electrician.

Contents

SQ-ELITE-8T LAYOUT	3	Customized Reset Ratio.	21
SQ-ELITE-8T OVERVIEW	4	Set Point (Not Adjustable in EMS Mode)	22
UNDERSTANDING OPERATION CONCEPT	5	Outdoor Cutoff Temperature.	22
Reset Ratio/Outdoor Reset	5	Target Offset.	22
PID Operation	6	Minimum Target	23
OSS Operation	6	Maximum Target.	23
Make Sure You Have the Right Control	7	Boiler Minimum Return	23
INITIAL SETUP	7	Minimum Return.	23
Selecting the System Features	7	Return Lag.	24
INSTALLATION	8	System Settings	24
Mounting the Enclosure	8	Program Change Settings.	24
Install the Sensors	9	Stage Settings	24
System Sensor Installation	9	Reaction Time	24
Outdoor Sensor Installation	9	Purge Delay	24
Wiring	10	Minimum Runtime.	24
Wiring the Power (Terminals 1, 2)	10	Standby Delay.	25
Wiring the Sensors	10	Last Stage Hold	25
Wiring the Domestic Hot Water (DHW) Sensor (Terminals 33, 34)	11	Throttle Range.	25
Wiring the Shutdown (Terminals 35, 36)	11	Lead Settings	26
Wiring the T-STAT (Terminals 35, 36)	11	Lead Boiler	26
Wiring the Setback (Terminals 35, 36)	11	Rotate Mode.	26
Wiring the Prove (Terminals 37, 38)	11	Setback Schedule	26
Wiring the System Output (Terminals 19, 20)	12	Setback	26
Wiring the DHW Pump (Terminals 21, 22)	12	Boost	27
Wiring the Combustion Air Damper (Terminals 23, 24)	12	Boost Period.	27
Wiring the Stages (Terminals 3 to 17)	12	Day/Night Schedules	27
Connecting to the SQ-Elite-EXT Panels and 4-20mA EMS Interface	13	Set Present Time	28
Selecting the SQ-Elite-EXT Panel Letter	13	DHW Settings	28
INSTALLER MENU SEQUENCE	14	DHW Priority Timer (Available with Parallel DHW Piping) 28	
Startup Settings	17	DHW Set Point (Requires an Optional DHW Temperature Sensor)	28
Program Change Settings.	17	Pump, Valve, and Combustion Air Damper Operation 29	
Startup Sequence	17	Run-On	29
Control Mode	17	Pump Exercise	29
Display Unit	17	Maintenance	30
Setting the 4mA and 20mA Set Points (Available in 4-20mA EMS only)	17	System & Outdoor Sensor Trim	30
Application.	18	History	30
DHW Piping (Available with Heating Only)	18	Configuration	30
DHW Pump Output	18	Display and Buttons.	30
Combustion Air Damper Output.	18	Boiler/C.Unit Settings	32
External Input Mode	18	Mode	32
Burner Type	19	RunTime.	32
Boiler Output	19	TROUBLESHOOTING	33
Total Boilers	19	MULTIPLE BOILERS WITH PUMPS PIPING/WIRING	
Staging	19	DIAGRAMS	34
Sequence	19	USER MENU SEQUENCE	35
Control Logic	20	Program Change Settings.	35
Sensor Fault.	20	Season	35
Setting the Control to Factory Defaults	20	Set Point (Not Adjustable in EMS Mode)	36
Operating Settings	21	Reset Ratio	36
Program Change Settings.	21	Customized Reset Ratio.	36
Season	21	Outdoor Cutoff Temperature.	37
Reset Ratio	21	Setback	37
		Day/Night Schedules	37
		SPECIFICATIONS:	40

SQ-ELITE-8T LAYOUT

Program Switch to restrict access to function changes. This Switch is covered with Enclosure Wiring Cover.

LEDs indicate associated relay's status

Button function is presented on bottom row of the display.

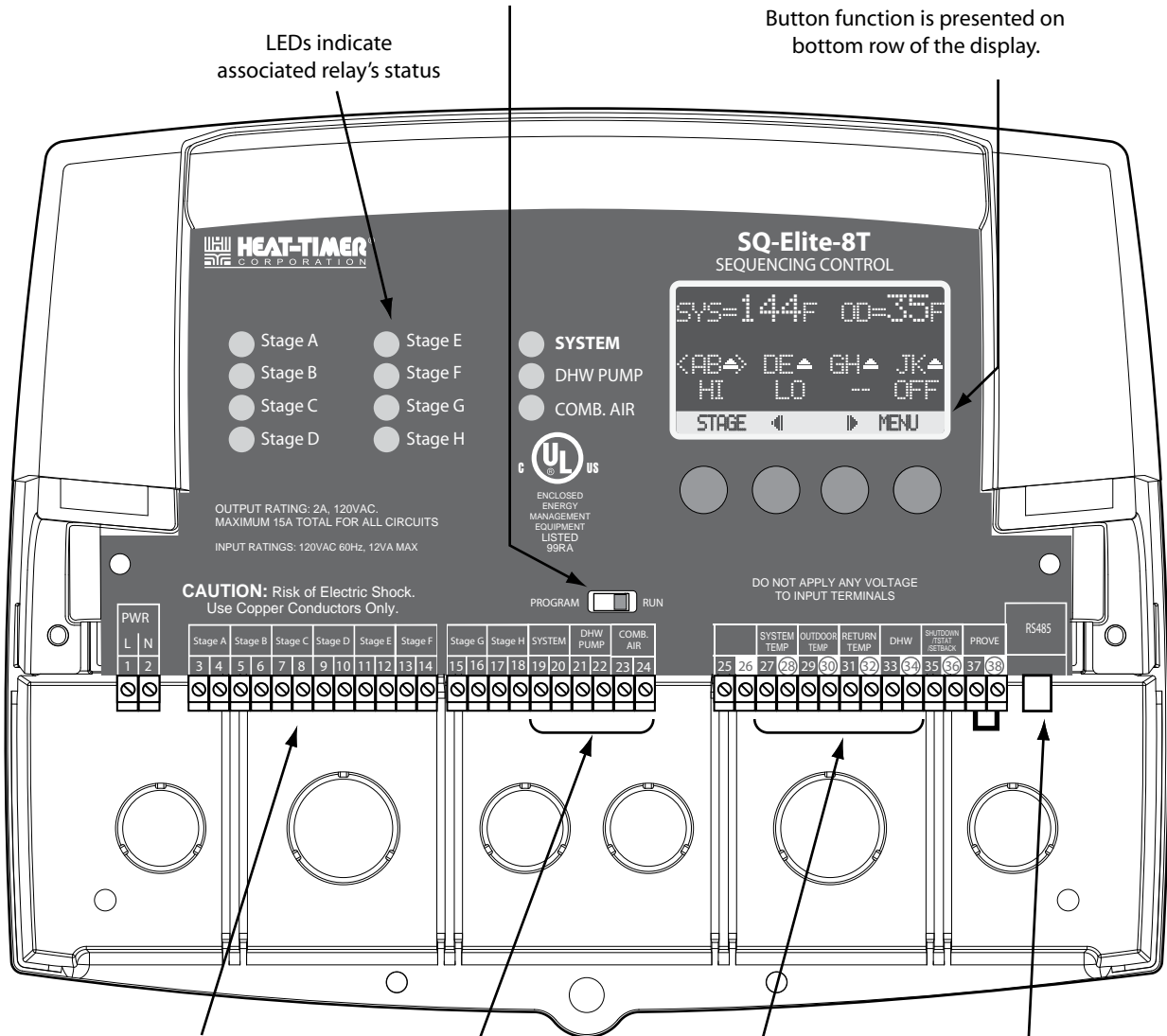

OUTPUT RATING: 2A, 120VAC.
MAXIMUM 15A TOTAL FOR ALL CIRCUITS
INPUT RATINGS: 120VAC 60Hz, 12VA MAX

CAUTION: Risk of Electric Shock.
Use Copper Conductors Only.

DO NOT APPLY ANY VOLTAGE
TO INPUT TERMINALS

Output Relays to manage the stages.

When connecting Temperature Sensors, no Polarity is observed. Prove terminals must be connected for SQ-Elite to operate stages.

System Output controls pumps, valves, or other system components. DHW Pump and Comb. Air relays are controlled when configured.

Connect to Extension panels to add additional stages or connect to 4-20mA EMS Interface for external set point.

SQ-ELITE-8T OVERVIEW

SEQUENCES UP TO 8 STAGES WITH PUMPS OR VALVES.

The SQ-Elite-8T is the perfect control whenever multiple boiler or chiller stages are required for hydronic heating or cooling applications. The SQ-Elite-8T controls the stages and their pumps or valves to maintain a precise system set point.

PID OR OVER-SIZED-SYSTEM (OSS) LOGIC

The SQ-Elite's control algorithm allows it to look at the rate of change in the system. If the load is changing quickly, the SQ-Elite can be set to OSS sequencing where it will react based on load changes. If the system oscillation is minimal as in heating applications, the SQ-Elite will make slow and gradual output adjustments. Therefore, the SQ-Elite adapts to specific system requirements and minimizes oscillation around the set point.

DIGITAL DISPLAY OF ALL SYSTEM SETTINGS

The SQ-Elite's alphanumeric digital display names each system parameter in simple English and shows its precise value. The easy to follow menu system allows users to quickly make changes to any system setting without having to learn any specialized codes or key commands.

AUTOMATIC ROTATION AMONG STAGES

Rotating the first stage to be activated on a call for output promotes even wear on each unit. The SQ-Elite has three modes of rotation: Manual, First-On/First-Off (FOFO), or Time. The Time rotates the lead stage every selected period from every hour to every 41 days.

OUTDOOR RESET WITH CUSTOMIZABLE CURVE

With its Outdoor reset feature, the SQ-Elite-8T is capable of changing its temperature target based on the outdoor temperature. It offers several parameters that can be used to fine tune the reset curve; Offset, Minimum, and Maximum Targets, and Night Setback Schedule or Setback using an External Signal. Furthermore, a customizable outdoor reset curve has been incorporated for unique applications where standard reset ratios will not suffice.

STANDBY UNIT OPTION

Any of the SQ-Elite-8T heating or cooling units can be configured as a Standby with an adjustable Standby delay. Assigning a specific unit to work in standby mode will remove it from the rotation. In this mode, the unit will be used for backup in large demand periods where the primary units will not suffice.

SYSTEM AND COMBUSTION AIR DAMPER OUTPUTS WITH PROVE INPUT

These outputs work with the control logic to operate a primary system pump and a combustion air damper. In addition, a System *Prove* input can be wired in to check the status of either of the components energized by the outputs before the stages can be activated.

NORMAL (LO/HI/LO/HI) OR PARALLEL (LO/LO/HI/HI) SEQUENCING

The SQ-Elite can sequence heating or cooling units as needed. For heating systems where higher efficiency is achieved using lower firing stages, the SQ-Elite offers the Parallel Sequencing option. It sequences all the low firing stages first before bringing the rest of the stages on. For other types of heating and cooling units, using the Normal Sequencing option brings the lower operating stage followed by the higher one of the lead unit. That will be repeated for each of the lag units.

MULTIPLE OR SINGLE STAGING

Unlike many boilers where, to fire a multi-stage boiler both low and high stage relays must be energized, some of the available cooling units require that the operation of the higher stages turn off the lower operating stages. This can be achieved by selecting Single from the Startup Staging menu.

ADD UP TO 16 STAGES

As a stand-alone, the SQ-Elite-8 is designed to control eight stages. However, it has the capability of expanding its control to two extension panels (SQ-Elite-EXT) each with eight stages. Thus, the SQ-Elite can control a total of up to 24 stages.

MONITOR SYSTEM RETURN TEMPERATURE

Using a smart algorithm, the SQ-Elite-8T can monitor the boiler return temperature using an optional return sensor mounted on the return line. Then, sequence the boilers to raise the return temperature above an adjustable Minimum Return.

DHW PUMP CONTROL WITH MULTIPLE PRIORITY OPTIONS

Having a *DHW* input either as a dry contact to be used with an external aquastat or as a temperature sensor that can be ordered separately, the SQ-Elite-8T can control a DHW pump using its built-in DHW Pump output relay. The user will have different priority options that varies based on the DHW piping design.

UNDERSTANDING OPERATION CONCEPT

The SQ-Elite-8T has multiple operating modes that satisfy most hydronic systems. In heating when the Outdoor Reset is selected, it can change the System Set Point based on outdoor temperature. Or, it can be set to Set Point and sequence stages to achieve a manually adjusted Set Point in either heating or cooling.

In Outdoor Reset, the SQ-Elite-8T controls a hot water heating system to provide a building with comfortable and even heat levels. The SQ-Elite varies the Target temperature of the circulating heating water in response to changes in the outdoor temperature.

The SQ-Elite-8T also controls the system circulating pump with an adjustable Outdoor Cutoff. In heating, when the outdoor temperature is above the Outdoor Cutoff, the System Pump will be off and no heating water is circulated through the system. When the outdoor temperature drops below the Outdoor Cutoff, the system pump relay is energized and the heating water starts to circulate through the system. The temperature of the heating water is controlled by the Reset Ratio parameters or the Set Point. In cooling applications, the SQ-Elite-8T turns off the cooling units and System Pump when the outdoor temperature rises above the Outdoor Cutoff setting.

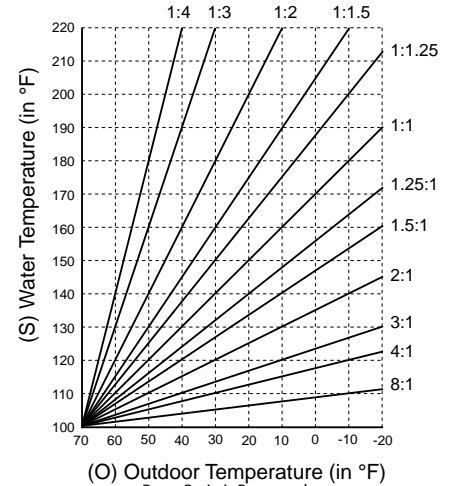

Reset Ratio Curves

RESET RATIO/OUTDOOR RESET

When a building is being heated, heat escapes through the walls, doors, and windows to the colder outside air. The colder the outside temperature, the more heat escapes. If you can input heat into the building at the same rate that it is lost out of the building, then the building temperatures will remain constant. The Reset Ratio is an adjustment that lets you achieve this equilibrium between heat input and heat loss.

The starting point for most systems is the 1.00 (OD):1.00 (SYS) (Outdoor Temperature : Heating Water Temperature) ratio. This means that for every degree the outdoor temperature drops, the temperature of the heating water will increase one degree. The starting point of the curves is adjustable, but comes factory selected at 70°F Outdoor Temp. and 100°F Water Temp. For example with a 1.00 (OD):1.00 (SYS) ratio, if the outdoor temperature is 50°F, this means the temperature has fallen 20° from the starting point of 70°F. Therefore, the heating water temperature will increase 20° to 120°F.

Each building has different heat loss characteristics. A very well insulated building will not lose much heat to the outside air, and may need a Reset Ratio of 2.00 (OD):1.00 (SYS) (Outdoor:Water). This means the outdoor temperature would have to drop 2 degrees to increase the water temperature 1 degree. On the other hand, a poorly insulated building with insufficient radiation may need a Reset Ratio of 1.00 (OD):2.00 (SYS). This means that for each degree the outdoor temperature dropped the water temperature will increase 2 degrees. The SQ-Elite has a full range of Reset Ratios to match any buildings heat loss characteristics.

A heating curve that relies not only on Outdoor temperature but also on the type of radiation will improve heat comfort. The following are suggested initial settings for different types of radiation based on average building insulation and heat loss. The contractor can fine tune these adjustments based on the specific building need.

With a 0° Offset, the ratio curves begin at 100° Water Temperature.

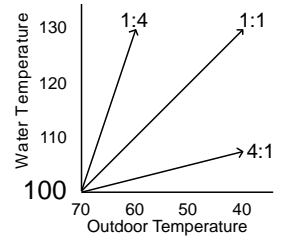

With a -20° Offset, the ratio curves begin at 80° Water Temperature.

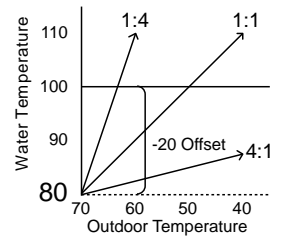

With a +20° Offset, the ratio curves begin at 120° Water Temperature.

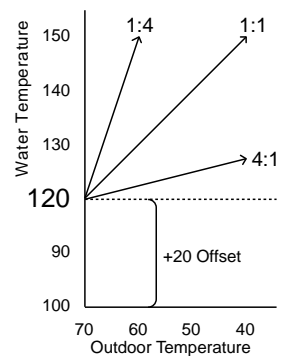

Type of Radiation in Building	Reset Ratio	Offset
Radiators (Steel & Cast Iron)	1.00 (OD) : 1.00 (SYS)	0°F
Baseboard (Finned copper tube & Cast Iron)	1.00 (OD) : 1.00 (SYS)	0°F
Radiant (High Mass/Concrete)	4.00 (OD) : 1.00 (SYS)	-10°F
Radiant (Low Mass/Joists)	2.00 (OD) : 1.00 (SYS)	-10°F
Fan Coils & Air Handlers	1.00 (OD) : 1.00 (SYS)	20°F

⚠ WARNING

When controlling a non condensing boiler, the Minimum Target temperature must be set to the boiler manufacturer specifications. In that case, system temperature must not go below such temperature.

The SQ-Elite-8T has multiple operating modes that satisfy most hydronic systems. It can sequence stages to achieve an adjustable Set Point or an Outdoor Reset Ratio (in heating applications only). Moreover, when used with the 4-20mA EMS Interface (HT# 926741-00) it can accept a 4-20mA signal as a set point. The 4-20mA EMS Interface must be purchased separately. This gives the SQ-Elite-8T the capability of being controlled remotely.

PID OPERATION

PID control logic is primarily used for building heating or cooling. The logic will utilize two primary settings to add or subtract stages. The Reaction Time is used to turn on/energize stages. On the other hand, the Minimum Runtime is used to turn off/de-energize stages. In heating applications, a call for heat, by either closing the *TSTAT* input or opening the *SHUTDOWN* input, and when the outdoor temperature is below the Outdoor Cutoff, the SQ-Elite-8T will turn on/energize the lowest firing stage of the Lead Boiler to start the Purge Delay. After the elapse of the purge period, the SQ-Elite-8T will start calculating the Reaction Period. If after a full Reaction Time the control logic foresees additional stages are needed, the SQ-Elite-8T will energize the following stage. If that stage was another boiler, that boiler has to go through a full Purge Delay before starting to calculate the Reaction Time for that stage. Otherwise, if the next stage was the higher firing stage on the same boiler, the Reaction Time will start from the moment the higher firing stage relay is energized.

When the SQ-Elite-8T PID logic foresees that the system will overshoot, regardless of the current system and target values, it will make sure that the last stage turned on/energized has elapsed a full Minimum Runtime before it is turned off/de-energized. Except for the lead stage, no additional stages will be turned off/de-energized until another full Minimum Runtime is elapsed. On the other hand, if the last stage is a lead stage, it will remain energized until the system reading exceeds the target set point by the Last Stage Hold value in addition to satisfying the Minimum Runtime condition. That is, if the Set Point was 150°F and the Last Stage Hold was set to 10°F, the lead stage will remain energized until the system reaches 160°F and a full Minimum Runtime elapses. This is useful in protecting the lead stages from short cycling.

OSS OPERATION

OSS is used in fast reacting application as in process applications, where maintaining a set point is critical. The OSS utilizes the Throttle setting, as a mean to calculate the number of stages the SQ-Elite-8T shall have on at any point. For every Throttle Range below the set point an additional stage shall be turned on/energized. That is, if the set point was 180°F and the Throttle setting was 5°F, if the System dropped below 175°F (180°F - 5°F), the lead stage will energize. With further decrease in the system value to 170°F (180°F - 5°F - 5°F), the second stage will energize.

As the system temperature rises towards the set point, stages will turn off. Using the previous example, when the system rise to 175°F boiler B will de-energize leaving only boiler A on. Boiler A will remain on until the system rises a one full Throttle range above the set point. This will leave the lead boiler A on until the temperature rises to 185°F then turn off/de-energize.

Throttling Example in Heating Mode

Set Point = 180°F

Throttling = 5°F

4 Boiler Stages, A, B, C, and D

Temperature	Calculation	Falling Temperature		Rising Temperature	
		Stage Turned On	Stages On	Stage Turned Off	Stages On
185°F	180 + (1)THR	---	None	A	None
180°F	180 - (0)THR	---	None	---	A
175°F	180 - (1)THR	A	A	B	A
171 to 174°F	---	---	A	---	A,B
170°F	180 - (2)THR	B	A,B	C	A,B
166 to 169°F	---	---	A,B	---	A,B,C
165°F	180 - (3)THR	C	A,B,C	D	A,B,C
161 to 165°F	---	---	A,B,C	---	A,B,C,D
160°F	180 - (4)THR	D	A,B,C,D	---	A,B,C,D

MAKE SURE YOU HAVE THE RIGHT CONTROL

If you need the SQ-Elite to do additional tasks that either are not listed or do not know how to configure them, contact Heat-Timer Corp. Sales Department either by Phone (973)575-4004, Fax (973) 575-4052, or by E-mail support@heat-timer.com.

INITIAL SETUP

Having an Initial Setup Program will ease the configuration of the SQ-Elite-8T and will provide the opportunity to utilize many of the energy saving features and give more comfortable heat when needed.

The program should consist of the following:

- Selecting the features that your system can utilize
- Installation: Install the Control, switches and sensors
- Setting the System Startup
- Setting the System Settings
- Setting the Stages
- Adjusting Reset Ratio and Water Offset (In Reset Mode Only)

SELECTING THE SYSTEM FEATURES

The SQ-Elite-8T has been designed with Hydronic heating and cooling as the primary purpose. With this in mind, many of the SQ-Elite-8T features can be utilized to ease, enhance, and improve your system performance. Some of these features are listed in this section.

HEATING OR COOLING WITH MULTIPLE OR SINGLE OUTPUT AT A TIME

- The SQ-Elite-8T is equipped to control multiple multi-stage boilers or chillers with or without pumps or valves for heating or cooling application.
- That, combined with the capability of energizing only a single stage of a multi-stage cooling unit when in high demand, makes the SQ-Elite-8T versatile for many industries.

OUTDOOR RESET, SET POINT, OR EXTERNAL 4-20MA SET POINT

- The SQ-Elite-8T can control the System Temperature either by adjusting the target according to the Outdoor Temperature (Outdoor Reset) or by maintaining an adjustable Set Point. The Outdoor Reset option, available in heating only, uses an Outdoor Sensor (supplied with the control) and achieves better fuel savings in addition to better comfort.
- Using the optional 4-20mA EMS Interface (HTC# 926741-00), the SQ-Elite-8T can receive an external set point through an EMS system.

PID OR OSS CONTROL LOGIC

- The SQ-Elite PID can be used for applications where system reaction is slow and requires a long period to achieve or measure the results. However, OSS, can be used for applications where the load changes frequently and the sequencing must match the load and its immediate change.

NUMBER OF STAGES

- The SQ-Elite can be configured to control up to eight stages. It can control up to 24 stages using a maximum of two SQ-Elite-EXT Extension Panels, each with eight stages.

STAGE PUMPS OR VALVES

- The SQ-Elite-8T can control multiple stages in addition to unit pumps or valves.

CONTROL DHW PUMP AND COMBUSTION AIR DAMPER

- The control of the DHW is based on either a temperature sensor, can be purchased separately, on the DHW source or using a dry contact from an aquastat. The SQ-Elite-8T provides multiple DHW Priority options based on the DHW piping. The Combustion Air Damper output can be used in conjunction with the *PROVE* input to check the status of the Combustion Air Damper's End Switch, System Pump's Flow Switch, or any other operating device before any stage is energized.

MONITOR BOILER RETURN

- The optional return line sensor, can be purchased separately, can be connected in heating applications to monitor and help protect the boilers from thermal shock and condensation caused by cool returns.

AUTOMATIC ROTATION AMONG BOILERS

- Rotating the lead unit to be activated on a call for output promotes even wear on all units. The SQ-Elite has three modes of rotation: Manual, First-On-First-Off, or Timed Rotation. This option automatically rotates the units every selected period from one hour to every 41 days (999 hours).

SETBACK/BOOST OR DAY/NIGHT SCHEDULING

Two Setback modes are available for the SQ-Elite:

- The Day/Night Scheduling provides an adjustable time-based schedule for the Setback. It will be available when Shutdown or Tstat is selected from the External Input Startup menu options. See page 18.
- When Setback is selected from the External Input Startup menu options, an external signal can be used to switch the operation of the SQ-Elite-8T in and out of setback mode. See page 18.
- The Boost can be used to bring the building to comfortable temperature settings after a Night or Setback period. It does that by increasing the target temperature in heating or decreasing it in cooling application for an adjustable period that follows the setback.

INSTALLATION

Each of the SQ-Elite and SQ-Elite-EXT consists of three primary enclosure components.

- The Enclosure Display Module:** contains the display, buttons, LEDs, and electric wiring terminals. It has two screws to hold it to the base. A program configuration switch, used to adjust SQ-Elite settings, is placed above the terminals. This switch is enclosed with the Enclosure Wiring Cover for security. The wiring terminals are of the plug-in type to ease installation and removal.
- The Enclosure Base:** contains the holes to mount and hold the control against the wall or any flat surface. All other enclosure components mount on the base. The bottom section of the Enclosure Base contains the wiring chamber with knockouts on the bottom to ease installation.
- The Enclosure Wiring Cover:** seals the wires from the external environment. It has two screws to hold it to the base and a hole to secure a lock on the wiring enclosure. A plastic web that separates the wiring chamber into high and low volt sections has been provided.

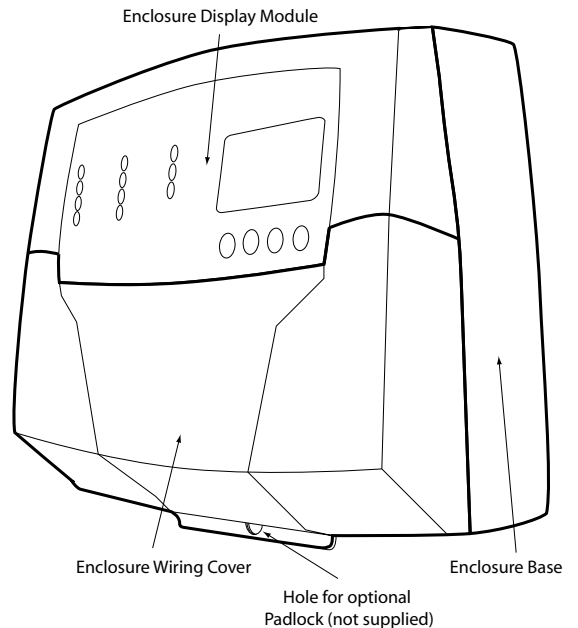

MOUNTING THE ENCLOSURE

- Select a location near the equipment to be controlled.
- The surface should be flat and sufficiently wide and strong to hold the SQ-Elite or SQ-Elite-EXT.
- Keep the control away from extreme heat, cold, or humidity. Ambient operating temperature is from 20 to 120°F.
- Remove the Enclosure Wiring Cover from the control enclosure by removing the two bottom screws.
- Remove the Enclosure Display Module by removing the middle screws.
- Screw the Enclosure Base to the surface through the upper and lower mounting holes on the back of the enclosure.
- Replace the Enclosure Display Module and replace the middle screws.
- Do not replace the enclosure wiring cover until all wiring is done.
- When purchasing a padlock for the enclosure, the maximum shank diameter should not exceed 1/4"

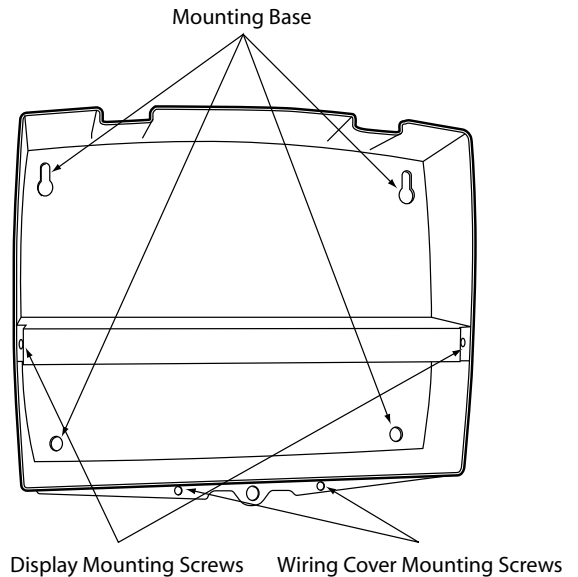

INSTALL THE SENSORS

SYSTEM SENSOR INSTALLATION

LOCATING THE SYSTEM SENSOR

- Put the System sensor approximately 10' feet past the last heating/cooling unit on the common supply header but before any takeoffs.
- The sensor must be located where it sees the output of all the stages. If a unit is piped so that the sensor does not see its output, the SQ-Elite-8T will not sequence the units correctly.
- Only use a Standard Brass Tube sensor (HTC #904250-00).
- The sensor wires can be extended up to 500' using a shielded 2-conductor cable (Belden #8760 or equivalent (#18/2)). Do not ground the shield at the sensor but at the panel using one of the terminals marked with an "O".
- Do not run sensor wires in conduit with line voltage wiring.

IMMERSION HEATING SYSTEM SENSOR (HSS) INSTALLATION

- Install a 3/8" ID immersion well (HT #350147-00 or 904011-00).
- Insert the sensor probe of the supplied sensor into the well.

STRAP-ON HEATING SYSTEM SENSOR (HSS) INSTALLATION

- Strap the sensor to the pipe using metal clamps. Do not over tighten the clamp. The sensor's concave surface must be facing the pipe for better temperature reading.
- Strap pipe insulation around the sensor and pipe.

Immersion Heating System Sensor

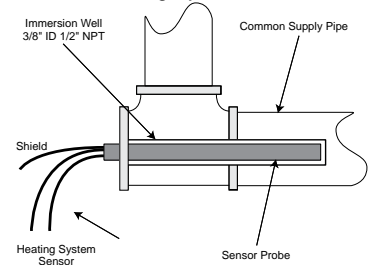

Strap-On Heating System Sensor

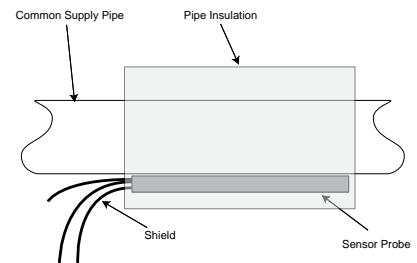

⚠ ALERT

If the System Sensor can not sense the correct system water temperature being supplied to the building, the SQ-Elite will not provide comfortable heat/cool levels. Be sure that it is located on the main supply pipe which can not easily be isolated from the system.

OUTDOOR SENSOR INSTALLATION

- Only use the Heat-Timer sensor included with the unit (HT# 904220-00).
- Locate the sensor in the shade on the north side of the building. The sensor should never be in direct sunlight.
- Be sure the location is away from doors, windows, exhaust fans, vents, or other possible heat sources.
- The sensor should be mounted approximately 10' feet above ground level.
- Adhere the Outdoor Label provided to the back of the sensor base.
- Use the Enclosure Base bottom knockout for the conduit. Use the locknut to hold the conduit and enclosure base together. Screw the cover to the base.
- If screws are used to affix the enclosure to the wall, make sure to seal around the sensor and wall except from the bottom.
- The sensor wires can be extended up to 500' using shielded 2-conductor cable (#18/2). Do not ground the shield at the sensor but at the control using the terminal marked with an "O".
- Do not run sensor wires in conduit with line voltage wiring.

⚠ WARNING

The SQ-Elite is an operating control only. All equipment must have all safety and limit controls required by code. It is the responsibility of the installer to verify that all the safety limits are working properly before the SQ-Elite is installed.

Outdoor Sensor

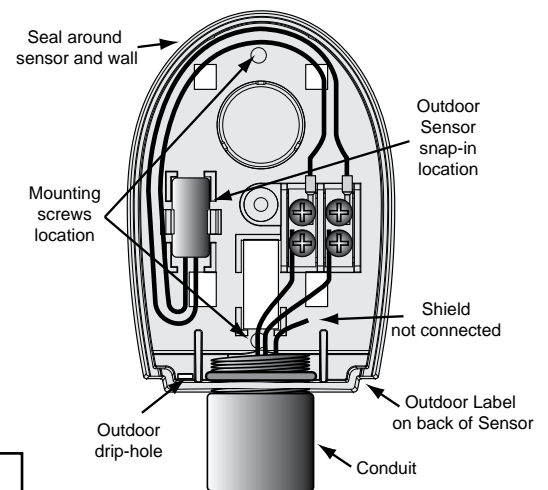

⚠ ALERT

Determining the proper location for the Outdoor Sensor is very important. The SQ-Elite will base its operation on the outdoor temperature information it receives from this location. If the sensor is in the sun, or covered with ice, its reading will be different from the actual Outdoor temperature.

WIRING

WIRING THE POWER (TERMINALS 1, 2)

- Bring the 120VAC 60Hz power wires through the bottom Knockout of the enclosure.
- Class 1 voltage wiring must enter the enclosure through a different opening from any Class 2 voltage wiring.
- Connect the hot line to the terminal marked L.
- Connect the neutral line to the terminal marked N.

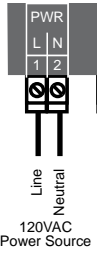

⚠ WARNING

Class 1 voltage wiring must enter the enclosure through a different opening from any Class 2 voltage wiring. Heat-Timer recommends installing a surge suppressor on the power source to the SQ-Elite.

⚠ WARNING

Connect the Temperature sensor shield at the control to the sensor terminal marked "O". Do not connect the Shield at the sensor end.

WIRING THE SENSORS

SYSTEM TEMPERATURE SENSOR WIRING (TERMINALS 27, 28)

- The SQ-Elite is designed to be connected to a temperature sensor (HT #904250-00) for immersion in a 3/8ID well (HT #350147-00 or 904011-00) located on the common header. Contact the factory for additional temperature sensor options.
- Temperature sensor wires can be extended up to 500' by splicing shielded 2-conductor cable (Belden #8760 or equivalent (#18/2)).
- Temperature sensors have no polarity. Connect the two wires from the sensor to the SQ-Elite-8T terminals marked *SYSTEM TEMP* 27, 28.
- Connect the shield to the circled terminal 28 with one of the sensor wires. Do not connect the shield at the sensor end.

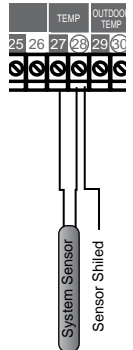

OUTDOOR SENSOR WIRING (TERMINALS 29, 30)

- When Outdoor Reset is selected, the SQ-Elite-8T will vary the system target based on the outdoor temperature.
- Whether in Set Point or Outdoor Reset modes, the outdoor sensor can be used as an Outdoor Cutoff. In heating, the SQ-Elite-8T will disable all Boilers when the outdoor temperature is above the adjustable Outdoor Cutoff temperature. However, in cooling it will disable the units when the outdoor temperature is below the Outdoor Cutoff. This feature will automatically be activated when an outdoor sensor is connected.
- For an outdoor sensor, use a Heat-Timer outdoor sensor (HT #904220-00).
- The sensor wires can be extended up to 500' using shielded 2-conductor cable (Belden #8760 or equivalent (#18/2)).
- Temperature sensors have no polarity. Connect the wires from the outdoor sensor to the SQ-Elite-8T terminals marked *OUTDOOR TEMP* - 29, 30. Connect the shield to the circled terminal 30 with one of the sensor wires. Do not connect the shield at the sensor end.

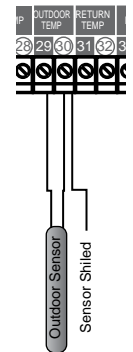

RETURN SENSOR WIRING (TERMINALS 31, 32) OPTIONAL (AVAILABLE IN HEATING ONLY)

- If the Return Sensor is connected, must be purchased separately, the SQ-Elite-8T will recognize it and alternate its temperature on the display with the Target temperature. If the Return temperature is below the Minimum Return, the SQ-Elite-8T will sequence stages based on the Return Sensor, Minimum Return, Calculated Target, and the actual System Temperature.
- The Return on the SQ-Elite-8T is designed to be connected to a temperature sensor that can be purchased separately (HT #904250-00) for immersion in a 3/8ID well (HT #350147-00 or 904011-00).
- The sensor wires can be extended up to 500' using shielded 2-conductor cable (Belden #8760 or equivalent (#18/2)).
- Temperature sensors have no polarity. Connect the wires from the outdoor sensor to the SQ-Elite-8T terminals marked *OUTDOOR TEMP* - 31, 32.
- Connect the shield to the circled terminal 32 with one of the sensor wires. Do not connect it to the sensor.

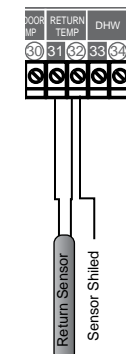

WIRING THE DOMESTIC HOT WATER (DHW) SENSOR (TERMINALS 33, 34)

- The DHW input can be used to raise system Set Point to 200°F or Maximum Target, whichever is lower. The DHW Piping on page 18 must be selected from the Startup Menu to determine the DHW Priority options.
- *DHW* Call terminals can be connected to either a dry-contact or a temperature sensor that can be purchased separately (HT #904250-00) for immersion in a 3/8ID well (HT #350147-00 or 904011-00)
- If using a dry contact, wire an aquastat or other controls to provide dry-contact closure on the *DHW* terminals.
- If using a sensor, the sensor wires can be extended up to 500' using shielded 2-conductor cable (Belden #8760 or equivalent (#18/2)).
- Temperature sensors have no polarity. Connect the wires from the DHW sensor to the SQ-Elite-8T terminals marked *DHW* - 33, 34. Connect the sensor shield to the circled terminal 34 with one of the sensor wires. Do not connect the shield to the sensor.
- If Shutdown was selected as the External Input, any DHW call will be ignored when the Shutdown is active.

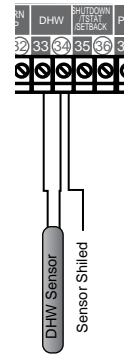

WIRING THE SHUTDOWN (TERMINALS 35, 36)

- This feature will only be available when Shutdown is selected as the External Input Mode option from the Startup menu on page 18.
- This feature can be used whenever it is desirable to turn off the SQ-Elite-8T stage outputs from a remote location or another controller (i.e. EMS input).
- When the Shutdown is enabled, all active stages will immediately turn off. The System Pump, Combustion Air, and unit pumps' or valves' relays will remain energized for the Run-On delay period and then turn off.
- The Shutdown signal must be a dry contact input. No voltage can be placed across the *SHUTDOWN* terminals.
- Bring the two wires from the dry contact to the *SHUTDOWN*- 35,36 terminals.
- When Shutdown is selected, Setback will be available using the programmed Day/Night schedule.

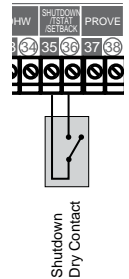

WIRING THE T-STAT (TERMINALS 35, 36)

- This feature can be used whenever it is desirable to switch the SQ-Elite-8T to operate from a remote location (i.e. EMS input or thermostat). It will only be available when Tstat is selected as the External Input Mode option from the Startup menu on page 18.
- When the Tstat is enabled by closing a dry contact, the SQ-Elite-8T will activate the heating/cooling logic.
- The Tstat signal must be a dry contact only. No voltage can be placed across the *TSTAT* terminals.
- Bring the two wires from the dry contact to the *TSTAT*- 35,36 terminals.
- When Tstat is selected from the Startup External Input mode, Setback will be available using the programmed Day/Night schedule.

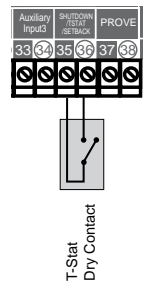

WIRING THE SETBACK (TERMINALS 35, 36)

- This feature can be used whenever it is desirable to switch the SQ-Elite to operate in Setback from a remote location (i.e. EMS input or external time clock). It will only be available when Setback is selected as the External Input Mode option from the Startup menu. See page 18.
- When the Setback is enabled by closing a dry contact, the Target will change by the Setback value. That is, in Heating, the Target will be reduced by the Setback value. On the other hand, in Cooling, the Setback will be added to the Set Point.
- The Setback signal must be a dry contact only. No voltage can be placed across the *SETBACK* terminals.
- Bring the two wires from the dry contact to the *SETBACK*- 35,36 terminals.
- When Setback is selected, No Day/Night Scheduling will be available.

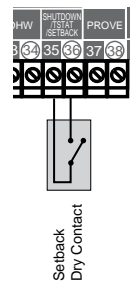

WIRING THE PROVE (TERMINALS 37, 38)

- The Prove feature is provided to check system component operation before energizing the stages. It can be used to check on the Combustion Air Damper by connecting it to the end switch of the damper. In this case, the Comb. Air Output option must be activated from the Startup Menu on page 18.
- If the Comb. Air Damper Output option was not activated, the *PROVE* input can be used to check on the System Output. A typical use of this feature is to check for system pump flow before energizing any stage.
- If the *PROVE* input is open on a call, the SQ-Elite will enable only the System Output. All stage outputs will be off when the *PROVE* input is open.
- A factory-installed jumper provides the System Prove signal. Do not remove the jumper unless it will be replaced by a System Prove signal.
- Bring the two wires from the dry contact to the *PROVE* - 37, 38 terminals. No voltage can be placed across the *PROVE* terminals

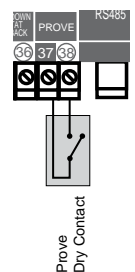

⚠ WARNING

The PROVE input cannot be used as a safety limit. All equipment must have its own certified limit and safety controls as required by local codes. No boiler stage will start unless the Prove terminals are shorted. DO NOT remove the PROVE jumper supplied unless replacing it with a Prove signal.

WIRING THE SYSTEM OUTPUT (TERMINALS 19, 20)

- The System output has a Normally Open (N.O.) relay that acts as a dry-contact. It does not source any power.
- Class 1 voltages must enter the enclosure through a different opening from any Class 2 voltage wiring.

System Output Operation in Set Point Mode

- In Heating, the System output relay will energize whenever the outdoor temperature drops below the Outdoor Cutoff or whenever a stage output is active. If no outdoor sensor is connected and the last boiler relay has de-energized, the System relay will remain energized for a period set by the Run-On and then de-energize.
- If the *PROVE* input is Open, the System relay will remain energized however, all stages will be de-energized. If a Prove is not required, the factory-installed jumper must remain connected for proper operation.
- In Cooling applications, the system relay will energize when the outdoor temperature is above the Outdoor Cutoff setting.
- A typical use of the System output is to activate a system pump or its starter. The pump can run whenever there is a call for heat/cool. When stages are no longer required, the pump will stay active for an adjustable Run-On delay and then de-energize.

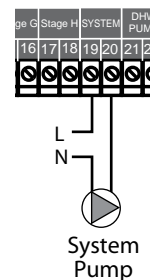
**System Output Operation in Reset Mode**

- The System output relay will energize whenever the outdoor temperature is below the Outdoor Cutoff.
- When the outdoor temperature rises 2°F above the Outdoor Cutoff, the System output will remain energized for the period set by the System Run-On and then de-energize.

WIRING THE DHW PUMP (TERMINALS 21, 22)

The SQ-Elite-8T can control the DHW Pump when the DHW Pump Output option is activated from the Startup Menu. See page 18.

- The SQ-Elite-8T will energize the DHW Pump whenever there is a call for DHW using a dry contact or when the DHW temperature falls below the DHW Set Point and DHW Differential when using a DHW sensor.
- The DHW Pump output relay is a Normally Open (N.O.) dry contact. It does not source any power.
- Class 1 voltages must enter the enclosure through a different opening from any Class 2 voltage wiring.
- If Shutdown was selected as the External Input (page 18), The Sq-Elite-8T will ignore a DHW call when the Shutdown is active.

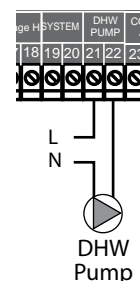
**WIRING THE COMBUSTION AIR DAMPER (TERMINALS 23, 24)**

The SQ-Elite-8T can control the Combustion Air Damper when the Comb. Air Output option is activated in the Startup Menu (Page 18). In addition, the *PROVE* input will function as the Combustion Air Damper status checker.

- The SQ-Elite will energize the Combustion Air Damper relay whenever there is a call to energize any of the unit stages.
- The Combustion Air output relay is a Normally Open (N.O.) dry contact. It does not source any power.
- Class 1 voltages must enter the enclosure through a different opening from any Class 2 voltage wiring.

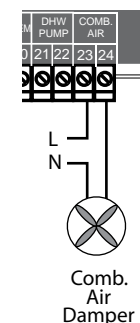
**WIRING THE STAGES (TERMINALS 3 TO 17)**

The SQ-Elite can be configured to operate the stages of the heating or cooling units. Moreover, it can be configured to operate the unit pumps or valves in addition to the unit stages.

- The relays are N.O. dry contacts only. They do not source any voltage.
- Wire the N.O. relay contacts in series with the unit's limit circuit.
- Class 1 voltages must enter the enclosure through a different knockout from any Class 2 voltage wiring.

WIRING THE STAGE OUTPUTS

- Each Stage output (A through H) has one (N.O.) relay.
- When wiring several multi-stage units, start with the lower stage of the first unit and wire it to Output A, followed by the higher stage of the same unit and wire it to Stage B.

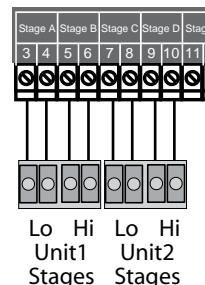

WIRING THE PUMP OR VALVE OUTPUTS

- If the SQ-Elite-8T is configured to operate Stage Pumps or Valves. They, must be wired to the stage output after the highest stage for that unit. That is, the low stage for the first unit must be connected to A and the higher stage of the same unit must be connected to Stage B. The unit valve or pump for the same unit must be connected to Stage C.

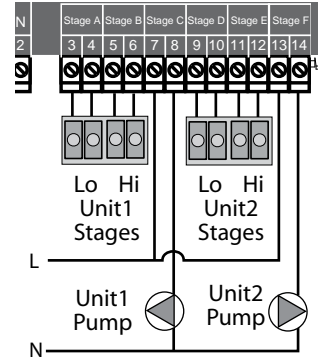

CONNECTING TO THE SQ-ELITE-EXT PANELS AND 4-20MA EMS INTERFACE

- The SQ-Elite is equipped with a phone socket (RS485) to connect to the SQ-Elite-EXT Extension panels or the 4-20mA EMS Interface using the provided 6-pin phone cable.
- Each SQ-Elite-EXT Extension has two RS485 communication ports. Use one to connect to the SQ-Elite. Use the other port to connect to the second extension or the 4-20mA EMS Interface.
- Additional compatible devices can utilize the second RS485 connection on the second SQ-Elite-EXT Extension. An example would be to use the 4-20mA EMS Interface (HT# 926741-00) to provide a 4-20mA set point signal to the SQ-Elite.

SELECTING THE SQ-ELITE-EXT PANEL LETTER

- The SQ-Elite is capable of communicating to two SQ-Elite-EXT Extensions. However, each extension must be identified as either A or B using the switch on each extension to avoid having communication problem.
- Extension A (Switch is set to "A") will operate stages "I" through "P". While Extension B (Switch is set to "B") will operate stages "Q" through "X".



Connecting SQ-Elite to Two Extension Panels and 4-20mA EMS Interface using RS485

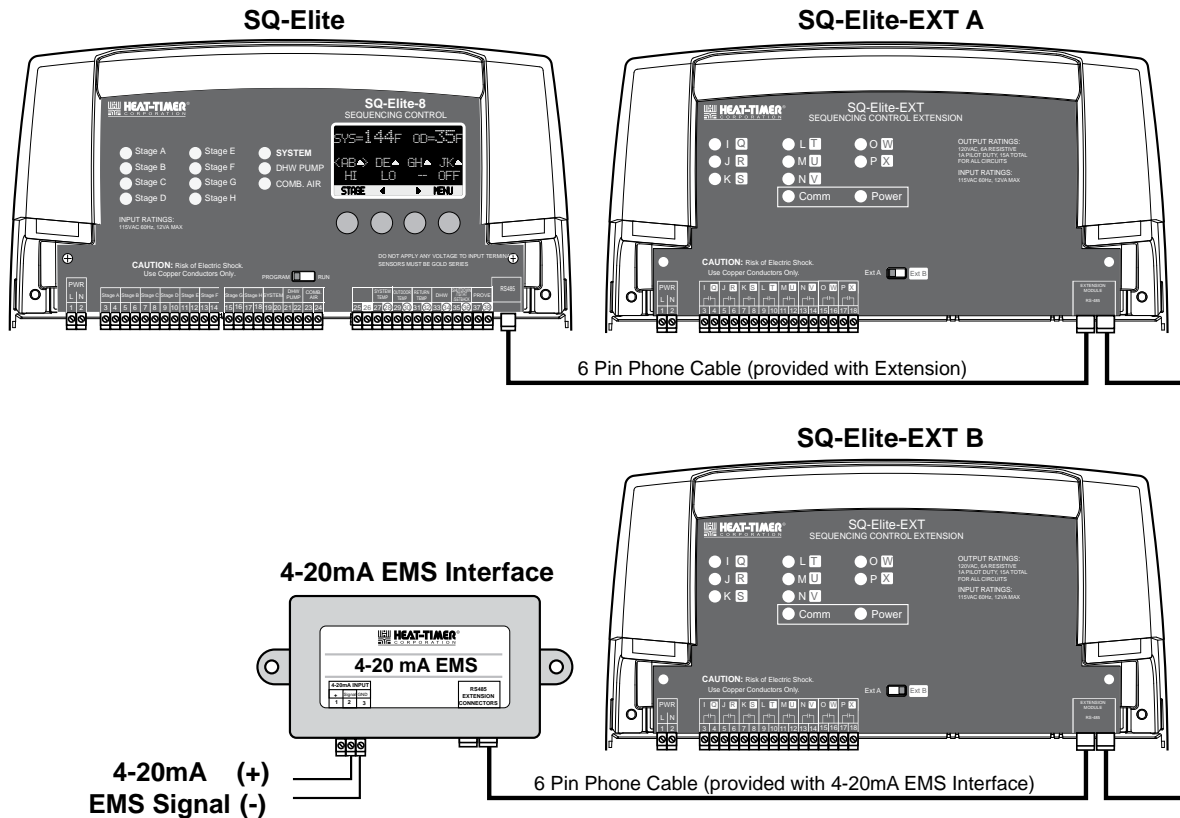

INSTALLER MENU SEQUENCE

STARTUP

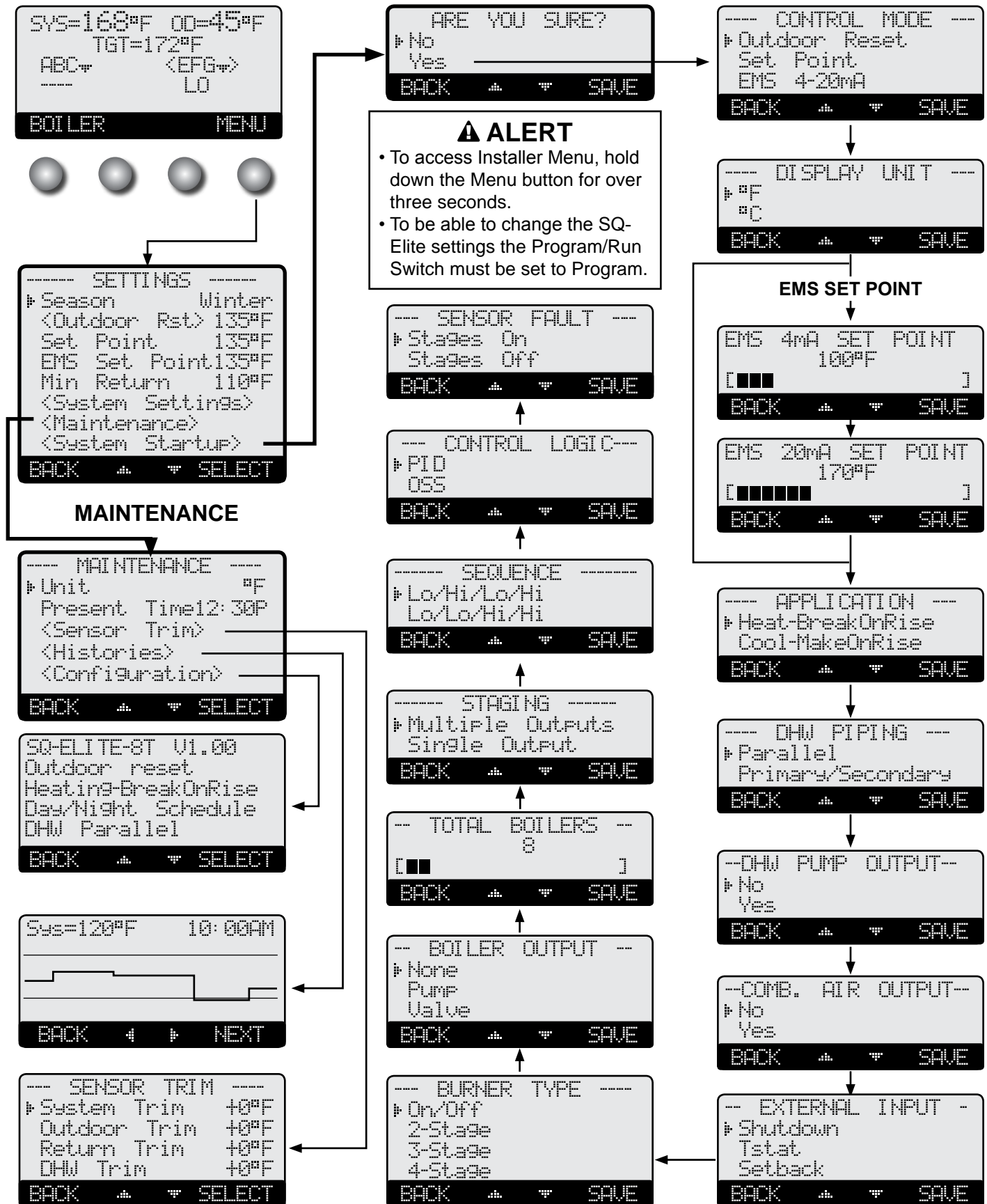

SET POINT

RESET RATIO

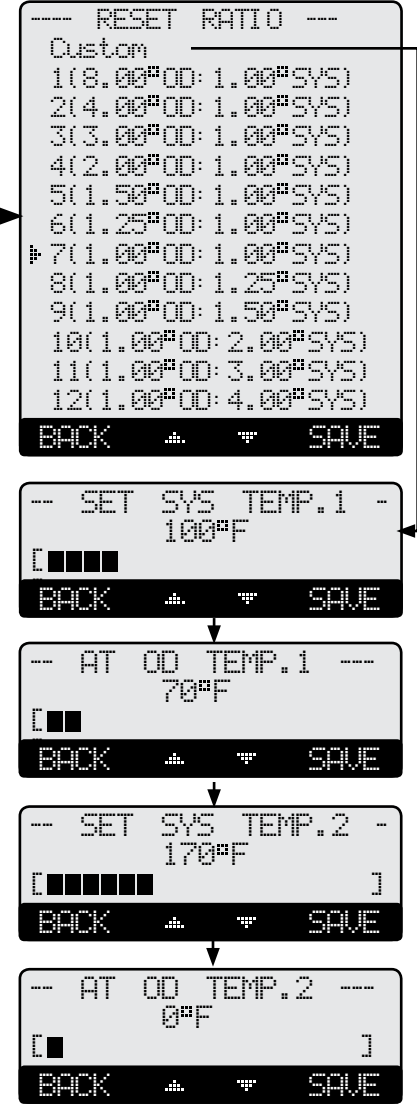
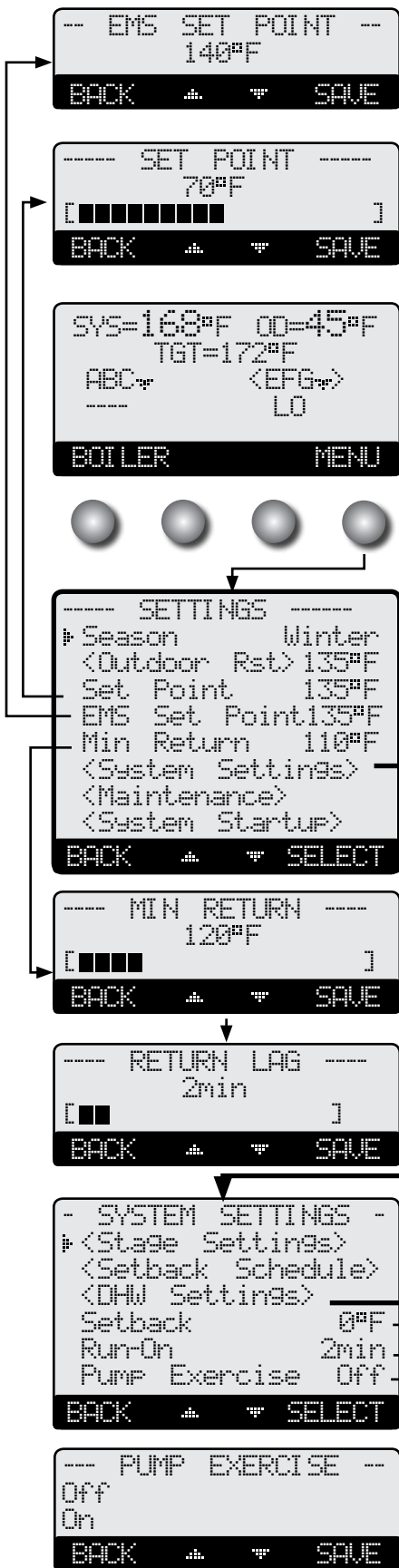

DHW SETTINGS

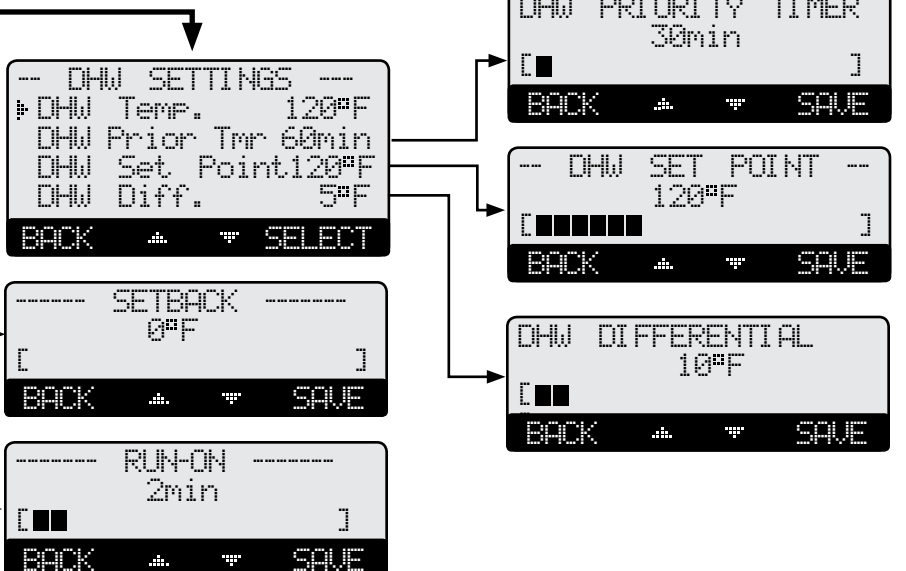

STAGE SETTINGS

```

- SYSTEM SETTINGS -
  > <Stage Settings>
  <Setback Schedule>
  <DHW Settings>
  Setback      0°F
  Run-On      2min
  Pump Exercise Off
  BACK ▲ ▼ SELECT
    
```

```

----- SETTINGS -----
  > Season      Winter
  <Outdoor Rst> 135°F
  Set Point    135°F
  EMS Set Point 135°F
  Min Return   110°F
  <System Settings>
  <Maintenance>
  <System Startup>
  BACK ▲ ▼ SELECT
    
```

```

-- STAGE SETTINGS --
  > Reaction Time 1min
  Purge Delay 0.0min
  Min Runtime 2min
  Standby Delay 10min
  Last Stage Hold 5°F
  Throttle 2°F
  <Lead Settings>
  BACK ▲ ▼ SELECT
    
```

```

-- LEAD SETTINGS --
  > Lead Boiler AB
  Rotate Mode Time
  BACK ▲ ▼ SELECT
    
```

```

-- LEAD ROTATION --
  > Time
  Manual
  FOFO
  BACK ▲ ▼ SELECT
    
```

```

AUTO ROTATE PERIOD
  [■] 24hrs
  BACK ▲ ▼ SAVE
    
```

```

-- LEAD BOILER --
  > AB
  CD
  BACK ▲ ▼ SELECT
    
```

```

-- REACTION TIME --
  [■■] 2min
  BACK ▲ ▼ SAVE
    
```

```

--- PURGE DELAY ---
  [ ] 0.0min
  BACK ▲ ▼ SAVE
    
```

```

- MINIMUM RUNTIME -
  [■■] 2min
  BACK ▲ ▼ SAVE
    
```

```

-- STANDBY DELAY --
  [■■■■] 10min
  BACK ▲ ▼ SAVE
    
```

```

LAST STAGE HOLD
  [ ] 0°F
  BACK ▲ ▼ SAVE
    
```

```

-- THROTTLE RANGE --
  [ ] 2°F
  BACK ▲ ▼ SAVE
    
```

SCHEDULES

Not Available when Setback is Selected from Startup Menu.

```

SETBACK SCHEDULE
  > Setback      0°F
  Present Time  **: **:
  Day Schedul  7:00Am
  Night Schedul 7:00Pm
  BACK ▲ ▼ SELECT
    
```

```

-- NIGHT SCHEDULE --
  07: **:Pm
  BACK ▲ ▼ SAVE
    
```

```

--- DAY SCHEDULE ---
  07: **:Am
  BACK ▲ ▼ SAVE
    
```

```

- SET PRESENT TIME
  **: **:
  BACK ▲ ▼ SAVE
    
```

```

----- SETBACK -----
  [ ] 0°F
  BACK ▲ ▼ SAVE
    
```

```

SYS=168°F OD=45°F
TGT=172°F
ABC+ <EFG+>
  --- LO
  BOILER MENU
    
```

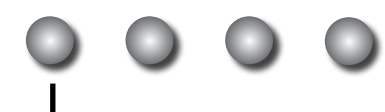

```

----- BOOST PERIOD ---
  [■■■■] 30min
  BACK ▲ ▼ SAVE
    
```

```

----- BOOST -----
  [ ] 0°F
  BACK ▲ ▼ SAVE
    
```

STAGE MENU

```

-- BOILER AB MODE -
  > Auto
  Standby
  Off
  On
  BACK ▲ ▼ SAVE
    
```

```

----- BOILER AB -----
  Mode      Auto
  Runtime   58hrs
  <Prev Boiler>
  > <Next Boiler>
  BACK ▲ ▼ SAVE
    
```

```

BOILER AB RUNTIME
  58hrs
  BACK ▼ CLEAR ▼ OK
    
```

STARTUP SETTINGS

Can be accessed by holding down the Menu button for over three seconds.

⚠ ALERT

A good practice after performing any Startup menu modifications is to check all operating settings and adjustments to match the new settings.

PROGRAM CHANGE SETTINGS

To be able to change the SQ-Elite settings the Program/Run Switch must be set to Program. The switch is located under the Enclosure Wiring Cover for security. The Enclosure Wiring Cover can be securely closed using a padlock.

PROGRAM RUN

STARTUP SEQUENCE

Hold Button: MENU/<System Startup>

- When powered, the SQ-Elite performs a self-test on its components. After the self-test diagnostics have been successfully completed, the SQ-Elite will initialize the panel.
- On the first power up, the System Startup screen will appear after the initialization is complete. If it doesn't, the SQ-Elite has already been configured.
- The System Startup menu sets the main parameters as the type of sensor, the type of output whether heating or cooling, the sequencing mode, and many other parameters described in this section.
- Before entering the Startup menu, several warnings will alert you to the consequences of making Startup changes.



CONTROL MODE

Outdoor Reset, Set Point, EMS 4-20mA

Default: Outdoor Reset

Hold Button: MENU/<System Startup>/.../Control Mode

- Outdoor Reset provides a variable set point based on outdoor temperature. Available for Heating applications only.
- Outdoor Reset mode requires the use of an outdoor sensor. DO NOT select Outdoor Reset without an outdoor sensor.
- Set Point mode does not require an outdoor sensor. If an outdoor sensor is connected in Set Point mode it will be used only as an Outdoor Cutoff point. That is, to turn the stages, system, and Comb. Air relays off.
- The EMS 4-20mA allows the SQ-Elite-8T to receive an external set point from an EMS/BMS system. This option requires the use of the 4-20mA EMS Interface (HT# 926741-00).
- You must select the 4mA (min) and 20 mA (max) Set Point values in the following screens.
- Connect the 4-20mA EMS Interface to the SQ-Elite-8T RS485 connection using the phone cable provided with the 4-20mA EMS interface.



DISPLAY UNIT

°F, °C

Default: °F

Hold Button: MENU/<System Startup>/.../Display Unit

- The SQ-Elite-8T can control boilers and chillers in hydronic environment where the temperature is the critical factor. It allows the user to display temperature information and settings in either °F (Fahrenheit) or °C (Celsius). Select the display unit that is best suited for your application.



SETTING THE 4MA AND 20MA SET POINTS (AVAILABLE IN 4-20MA EMS ONLY)

4mA from -10°F/-23°C to 240°F/116°C

Default: 100°F/38°C

20mA from -10°F/-23°C to 240°F/116°C

Default: 170°F/77°C

Hold Button: MENU/<System Startup>/.../EMS 4mA Set Point/EMS 20mA Set Point

- If EMS 4-20mA is selected from the Control Mode menu as the temperature set point source, the user must purchase a Heat-Timer 4-20mA EMS Interface (HT# 926741-00) to accept the 4-20mA signal and transmit it to the SQ-Elite-8T.
- In addition, the user will need to set the temperature range parameters. First, set the 4mA temperature set point, then the 20mA temperature set point.
- To shutdown the control using the EMS signal, send a signal that is above or below the 2-22mA range. The display will show the message "Shutdown by EMS" and all stages will de-energize. However, the System, Comb. Air, and Unit Pumps and Valves will continue for the Run-On delay period and then de-energize.



APPLICATION

Heating-BreakOnRise, Cooling-MakeOnRise **Default: Heating-BreakOnRise**

Hold Button: MENU/<System Startup>/.../Application

- The SQ-Elite-8T offers two application modes, Heating and Cooling. In Heating, the SQ-Elite will sequence stages and when the system temperature is below the set point. In addition, the system relay will energize when the outdoor temperature is at or below the Outdoor Cutoff setting.
- In Cooling, the SQ-Elite-8T will sequence stages and when the system temperature is above the set point. In addition, the system relay will energize when the outdoor temperature is at or above the Outdoor Cutoff setting.
- No Return Temperature monitoring or DHW options will be available in cooling applications.



DHW PIPING (AVAILABLE WITH HEATING ONLY)

Parallel, Primary/Secondary

Default: Parallel

Hold Button: MENU/<System Startup>/.../DHW Piping

- When Parallel is selected, the SQ-Elite-8T will offer a DHW Priority Timer. The DHW priority will only take place during heating periods. See the DHW Priority Timer on page 28.
- The priority will allow the DHW Pump relay to energize while de-energizing the System relay when there is a DHW call during heating. However, during Summer, only the DHW Pump relay will energize on a DHW call.
- Selecting the Primary/Secondary option will energize the System relay with the DHW Pump relay whenever there is a call for DHW even during the Summer or when outdoor temperature is above the Outdoor Cutoff. No priority will be available.



▲ ALERT

A DHW call can be initiated by either a dry contact or using a Heat-Timer Sensor (HT #904220-00 or 904250-00) for immersion in a 3/8ID well (HT #350147-00 or 904011-00). The use of a sensor will allow the adjustment of the DHW Set Point and DHW Differential.

DHW PUMP OUTPUT

No, Yes

Default: Yes

Hold Button: MENU/<System Startup>/.../DHW Pump Output

- The SQ-Elite-8T can control the operation of the DHW Pump. This option allows the user to select if the SQ-Elite-8T should be controlling the DHW Pump or not.



COMBUSTION AIR DAMPER OUTPUT

No, Yes

Default: Yes

Hold Button: MENU/<System Startup>/.../Comb. Air Output

- The SQ-Elite can control the operation of the Combustion Air Damper. This option allows the user to select if the SQ-Elite should be controlling the Combustion Air Damper or not.
- If Yes is selected, the SQ-Elite will energize the Comb. Air relay whenever there is a call for a boiler and will use the *PROVE* input to check on the status of the Combustion Air Damper. When the last stage is de-energized, the Comb. Air relay will remain energized for the Run-On period and then de-energize.
- On a prove failure situation, the message "Wait for Comb. Prove". No boiler stages will be active until the Prove input is Shorted.
- If Prove fails after the boiler stages where energized, the stages will de-energize and the message "Comb. Prove Failure" will display until the situation is rectified.
- If No is selected, the *PROVE* input will be used to check System status instead of the Combustion Air Damper.



EXTERNAL INPUT MODE

Shutdown, Tstat, Setback

Default: Shutdown

Hold Button: MENU/<System Startup>/.../External Input

- The Shutdown function allows the SQ-Elite-8T to receive a remote Shutdown signal to terminals 35 and 36 to turn off all relays including all boilers stages.
- When Shutdown is selected, DHW calls will be ignored unless the control is out of Shutdown.



- The Tstat option gives terminals 35 and 36 the capability of functioning as a heat-call. That is, when terminals 35 and 36 are shorted, the SQ-Elite-8T will sequence the stages. However, when they are opened, all stages will turn off.
- Setback is used to lower the set point when less load is required during nights and weekends.
- For setback operation, the SQ-Elite-8T can either utilize its built-in night schedule, available when Shutdown or Tstat is selected as the External Input, or an external dry contact signal to switch to setback by selecting Setback from this menu.

BURNER TYPE

On/Off, 2-Stage, 3-Stage, 4-Stage

Default: On/Off

Hold Button: MENU/<System Startup>/.../Burner Type

- The SQ-Elite can sequence from a single stage and up to four stages per heating or cooling unit. Select the option based on your boiler or cooling number of stages.

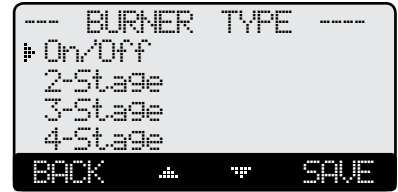

BOILER OUTPUT

None, Pump, Valve

Default: None

Hold Button: MENU/<System Startup>/.../Boiler Output

- When None is selected, the SQ-Elite-8T will sequence multiple heating or cooling units without any additional unit pumps or valves.
- The Pump option allows the SQ-Elite-8T to control the cooling or heating unit stages in addition to the unit pumps. The pump stage will run for the Run-On delay after the lower stage of that unit has de-energized.
- The Valve option functions similar to the pump option except that when all stages are off and after the Run-On delay has elapsed, the Lead unit's valve relay will remain energized to allow for pump flow across the system. The lead unit's valve will remain energized until the Outdoor temperature rises above the Outdoor Cutoff or when the Shutdown or Summer is activated.



TOTAL BOILERS

from 1 to 24

Default: varies based on Burner Type and Boiler Output

Hold Button: MENU/<System Startup>/.../Boiler Output

- This option in combination with Burner Type and Boiler Output Startup options will determine the total number of outputs the SQ-Elite will need to control.
- If the total number of stages selected, including unit pumps or valves, is more than the control and extension stages, the additional units containing these stages will have CE as their status and will seize to operate.

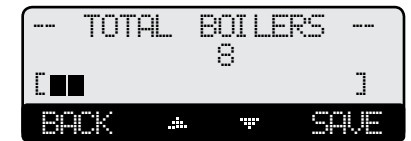

STAGING

Multiple Outputs, Single Output

Default: Multiple Outputs

Hold Button: MENU/<System Startup>/.../Staging

- Most units will require that the higher output stages be energized after the lower output stages. These units will need to select the Multiple Output option. That means, both Low and High Output stages must be energized to achieve the unit's maximum output.
- Some units require that when the higher output stages are required, the lower stages must de-energize. To operate these units, the user must select the Single Output option.



SEQUENCE

Lo/Hi/Lo/Hi, Lo/Lo/Hi/Hi

Default: Lo/Hi/Lo/Hi

Hold Button: MENU/<System Startup>/.../Sequencing

- Some units run more efficient when the lower stages are energized alone than with the higher stages. These types of units should select Lo/Lo/Hi/Hi. Then, the SQ-Elite will sequence the lower stages of all Automatic units before sequencing the higher stages.
- For the rest of the unit types, the Lo/Hi/Lo/Hi should allow the staging of the lower stage of the lead unit followed by the higher stage of the same unit. Then when more stages are needed, it will fire the lower stage of the lag unit followed by the higher stage of the lag unit.



CONTROL LOGIC

PID, OSS (Over-Sized-System)

Default: PID



Hold Button: MENU/<System Startup>/.../Sequencing

- The PID option allows the SQ-Elite to sequence stages based on the Reaction Time and the Boiler Minimum Run Time. The PID relies on the rate of change in the System Temperature. The PID logarithmic calculations foresee changes and sequence stages based on those changes. It is the most efficient operation for most heating and cooling applications.
- The Oversize option sequence stages based on how many Throttling ranges (differentials) is the system temperature away from the Target Temperature. In Heating and at one Throttling range below the Set Point, only one stage will be on. For each additional Throttling range below the Set Point, an additional stage will be activated. The last stage on will be allowed to exceed the Set Point by one Throttling range before turning off that stage. This helps to prevent the last stage from short cycling.

When PID is Selected, the following are the settings that directly affects this modes operation:

- Reaction Time (pg 24) SELECT *Settings/System Settings/Stage Settings/Reaction Time*
- Purge Delay (pg 24) SELECT *Settings/System Settings/Stage Settings/Purge Delay*
- Minimum Run Time (pg 24) SELECT *Settings/System Settings/Stage Settings/Min Runtime*
- Standby Delay (pg 25) SELECT *Settings/System Settings/Stage Settings/Standby Delay*
- Last Stage Hold (pg 25) SELECT *Settings/System Settings/Stage Settings/Last Stage Hold*

When Oversize (OSS) is Selected, the following are the settings that directly affects this modes operation:

- Throttle (pg 25) SELECT *Settings/System Settings/Stage Settings/Throttle*

SENSOR FAULT

Stages On, Stages Off

Default: Stages On



Hold Button: MENU/<System Startup>/.../Sensor Fault

- The Sensor Fault will determine the operating status of all output stages set to Auto or Standby when a sensor reads Short or Open.
- The Shutdown or Tstat activation will take precedence over the Sensor Fault status. That means, if Stages On is selected and the Shutdown was active, all stages will be Off on a sensor fault.

RESET MODE

- When Stages-On is selected, the SQ-Elite-8T will turn all unit stages On when the System reads *Short* or *Open* and the Outdoor is below the Outdoor Cutoff. When the Outdoor reads *Short* or *Open*, the SQ-Elite-8T will change the Target to the Maximum Target.
- When Stages-Off is selected, the SQ-Elite-8T will turn all stages Off when the System reads *Short* or *Open*. However, when the Outdoor reads Short or Open, the SQ-Elite-8T will change the Target to the Minimum Target.

SET POINT MODE

- When Stages-On is selected, the SQ-Elite-8T will turn all stages On when the System sensor reads *Short* or *Open*.
- When Stages-Off is selected, the SQ-Elite-8T will turn all stages Off when the System sensor reads *Short* or *Open*.
- The Outdoor Sensor Short or Open status will not affect the control operation in Set Point mode.

SETTING THE CONTROL TO FACTORY DEFAULTS

To Reset the SQ-Elite control to its original factory defaults, power down the control. Hold down the two right most buttons while powering the control back up until the *Total Clear Started* screen appears. The Display will direct you to the Startup menu to program the control after the defaults are loaded.

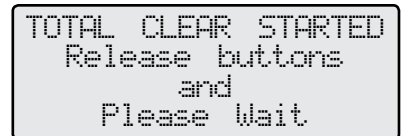

NOTE: When resetting the control to original factory defaults all control settings will be overwritten and will no longer exist.

▲ ALERT

Do not turn off power to control until all Startup settings have been made. Otherwise, the next power-up will be set to many Startup factory settings that might not fit your application.

OPERATING SETTINGS

PROGRAM CHANGE SETTINGS

To be able to change the SQ-Elite settings the Program/Run Switch must be set to Program. The switch is located under the Enclosure Wiring Cover for security. The Enclosure Wiring Cover can be securely closed using a padlock.



SEASON

Winter, Summer

Default: Winter

Button: MENU/Season

- In Heating Mode, the SQ-Elite-8T will turn all boiler relays off when it is in Summer setting. The Message Display Line will read `Summer` to show status. However, a DHW call will bring the boilers back on if needed. When in Winter, the SQ-Elite-8T will activate the System relay whenever the Outdoor temperature falls to or below the Outdoor Cutoff setting. In addition, it will begin heating whenever the System temperature falls below the Set Point Temperature. The Message Display Line will not display any season information.
- In Cooling Mode, the SQ-Elite-8T will turn all stage relays off when it is in Winter setting and the Message Display Line will read `Winter` to show that status.. However, in Summer , all stages will be off.
- When the season is over, it is a good practice to switch the SQ-Elite-8T Season setting. This will allow DHW calls in heating to operate the boilers when needed.

⚠ ALERT

DO NOT turn power off to the SQ-Elite-8T when in off-season. If you do so, the battery will run down and have to be replaced. Instead, switch to Summer or Winter.



RESET RATIO

Custom, 1(8.00°OD : 1.00°Sys) to 12 (4.00°OD : 1.00°Sys)Default: 1(1.00°OD : 1.00°Sys)

Hold Button: MENU/<Outdoor Reset>/Reset Ratio

In Outdoor Reset Only

- The Reset Ratio applies only to Heating applications.
- The Reset Ratio determines how the system Target temperature will vary based on the outdoor temperature. With any of the ratios, the colder it becomes outside, the hotter the temperature of the system water. (See Understanding Operation Concept on page 5)
- With a 1.00 (OD):4.00 (SYS) ratio, the System water temperature (SYS) will increase rapidly as the outside temperature falls, hitting the Maximum of 240°F at 35°F outside temperature. With a 4.00 (OD):1.00 (SYS) ratio, the System temperature (SYS) will increase slowly as the outside temperature falls. Even at -30°F, the system water will only be 125°F, and at 22°F outside, the system water will be 112°F. Such a low Reset Ratio might be used with radiant floor heating applications.
- With most baseboard heating applications, a 1.00 (OD):1.00 (SYS) setting is a good place to start. With a 1.00 (OD):1.00 (SYS) ratio, for every degree the outside temperature falls, the system water temperature is increased one degree.
- If required: **Adjust the RESET RATIO in cold weather.** If the ambient building temperature are cold in cold weather, move the ratio to a higher selection. That is, if 1.00 (OD):1.00 (SYS) was initially selected, change the selection to 1.00 (OD):1.25 (SYS). If the building temperature are too warm in cold weather, move the ratio to a lower selection. That is, if 1.00 (OD):1.00 (SYS) was initially selected, change it to 1.25 (OD):1.00 (SYS).
- After selecting the Reset Ratio, pressing the `SAVE` button will switch to the Outdoor Cutoff setting option.

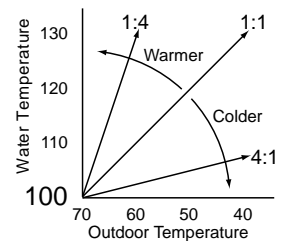
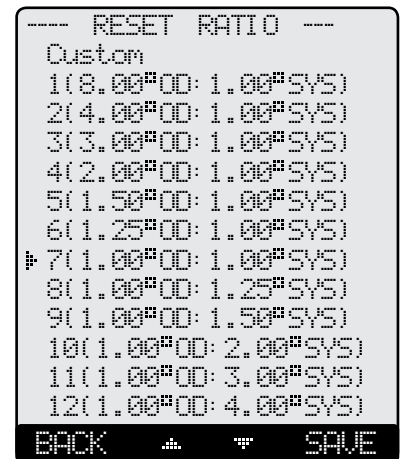

CUSTOMIZED RESET RATIO

Hold Button: MENU/<Outdoor Reset>/Reset Ratio/Custom

- For situations where the available reset ratios do not provide the perfect building heat-loss equilibrium, the customized option can be used by selecting `Custom` from the Reset Ratio menu option.
- It provides the user with the capability of assigning two points on the reset ratio diagram and use the line that connects those two points as the customized reset ratio curve. Each of the two points will need a specific System and Outdoor Temperature to identify it on the diagram.

- To Set the first point, specify Sys Temp 1 and OD Temp 1. Then, specify Sys Temp 2 and OD Temp 2, to set the second point on the curve. The two points can be anywhere on the line, not necessarily at the ends.
- The chart shows an example of a customized curve 6(OD):5(SYS) that does not exist in the standard curve options. If the outdoor temperature reaches 30°F, the system target will be 145°F.
- Remember that the Offset, Min Target, and Max Target apply to all reset ratios including the customized reset ratio ones.

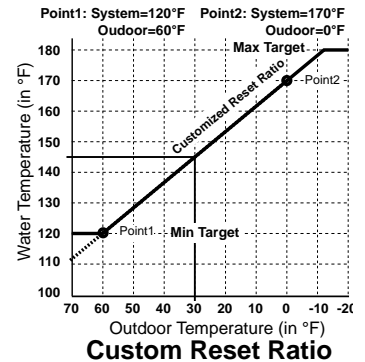
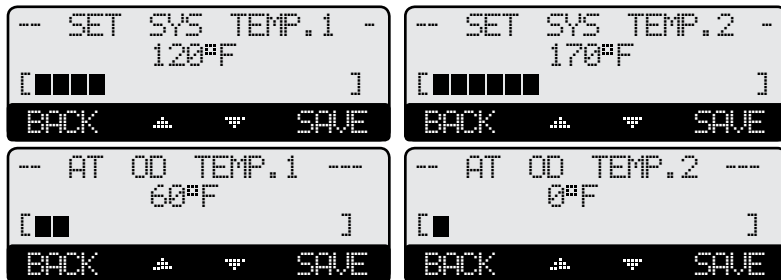

SET POINT (NOT ADJUSTABLE IN EMS MODE)

Adjustable from -10°F/-23°C to 230°F/110°C

Default: 70°F/21°C

Button: MENU/Set Point

In Set Point or EMS 4-20mA

- The Set point is the temperature value the SQ-Elite-8T will use to control the system.
- The SQ-Elite-8T will add, subtract, or hold the stages of the heating or cooling units to maintain the system temperature around the Set point.
- The system can be expected to fluctuate around the set point. The amount of fluctuation depends on the System Settings and Stage Settings.
- If an Outdoor Sensor was connected, pressing the SAVE button will continue to the Outdoor Cutoff setting option.
- If the EMS Mode was Enabled, the Set Point will be set by the EMS/BMS system and will be available as a read only.
- The range of Set Point in the EMS is set in the Startup menu at 4mA and 20mA.
- Any reading below the 2mA or above 22mA will indicate a "Shutdown by EMS" message on the Message Line.



OUTDOOR CUTOFF TEMPERATURE

Adjustable Off, from 20°F/-7°C to 100°F/38°C, On

Default: 70°F/21°C

Hold Button: MENU/Set Point/Outdoor Cutoff

in Set Point

Hold Button: MENU/<Outdoor Reset>/Outdoor Cutoff

in Reset

- In Outdoor Reset mode, Outdoor Cutoff will always exist. However, in Set Point mode, if the outdoor sensor is installed, the Outdoor Cutoff screen will automatically appear after the temperature Set Point has been selected.
- In Heating applications, when the outdoor temperature falls to the adjustable Outdoor Cutoff temperature, the SQ-Elite-8T will control and sequence the boiler stages to hold the calculated temperature.
- When the outdoor temperature rises to the Outdoor Cutoff plus a 2°F differential, the SQ-Elite-8T will turn all boilers off. The System, Combustion Air Damper, and any other Pump or valve relays that were energized will remain energized for the Run-On delay and then de-energize.
- In Cooling applications, when the outdoor temperature rises to the adjustable Outdoor Cutoff temperature, the SQ-Elite will control and sequence the cooling unit stages to hold the Set Point temperature.
- In addition, the Outdoor Cutoff can be set to ON or OFF. In the ON option, the System Relay will run regardless of the Outdoor temperature and the burner stages will be active to hold the target water temperature.
- In the OFF position, the system pump will always be off and all stages will be off as well.



TARGET OFFSET

Adjustable from 40°F/22°C to (-40°F/-22°C)

Default: 0°F/0°C

Hold Button: MENU/<Outdoor Reset>/Offset

in Outdoor Reset only

- The Offset setting moves the Reset Ratio curve vertically. This means that, regardless of the Outdoor temperature, or the Reset Ratio that has been selected, when the Offset setting is changed, that change is directly added to or subtracted from the calculated temperature. For example, if the Set Point temperature was 130°F and the Offset was changed from 0° to 10° (an increase of 10°), the Set Point would increase to 140°F.



- The Offset setting does not change the ratio selection. For instance, with 1.50 (OD):1.00 (SYS) Reset Ratio, the System water temperature will always increase one degree for every 1.5 degree change in the Outdoor temperature. What the Offset does is add or subtract a constant temperature value. (See Understanding Operation Concept on page 5)
- The Minimum and Maximum Target will take precedence over the Offset. That is, if the Max Target was set to 170°F and the Offset was set to 10°F. If the set point was 165°F, the new calculated set point based with the Offset should be 175°F. However, it will not exceed 170°F due to the Maximum Target setting.
- If required: **Adjust the Water Offset in mild weather.** If the ambient building temperatures are too warm in the mild weather, decrease the Target Offset. If the ambient building temperatures are too cold in the mild weather, increase the Target Offset. The rule of thumb for baseboard radiation is to change the Offset 4°F for every 1°F you wish to change the building temperatures. In radiant heat applications, change the Offset 1°F or 2°F for every 1°F you wish to change the building temperature.

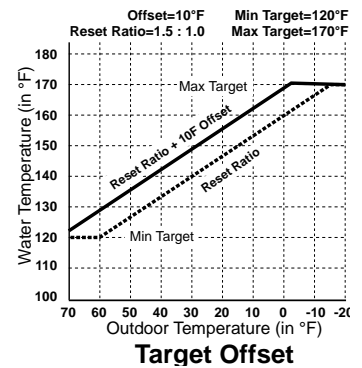

MINIMUM TARGET

Adjustable from 70°F/21°C to 180°F/82°C

Default: 80°F/27°C

Hold Button: MENU/<Outdoor Reset>/Min. Target

in Outdoor Reset only

- The Minimum Target must be set to the boiler manufacturer’s specification. The SQ-Elite-8T will calculate the Set Point based on the Outdoor temperature, the Reset Ratio, and the Offset value. The SQ-Elite-8T will control all boilers to hold either the Set Point temperature, or the Minimum Target, whichever is higher.
- The Minimum Target must be at least 20°F lower than the Maximum Target (See next setting).



MAXIMUM TARGET

Adjustable from 90°F/32°C to 240°F/116°C

Default: 240°F/116°C

Hold Button: MENU/<Outdoor Reset>/Max. Target

in Outdoor Reset only

- This is the highest Target temperature the SQ-Elite-8T will calculate for the heating system.
- When using in-floor radiant system, it should be set according to the tubing or floor manufacturer’s specification.
- The Maximum Target must be at least 20°F higher than the Minimum Target (See previous setting)..



BOILER MINIMUM RETURN

When a return sensor is connected to the SQ-Elite-8T, it will monitor and control the boiler return when in Heating mode. It does that by monitoring the Target temperature (TGT), System temperature (SYS), Minimum Return, and actual return. (RTN). When the SQ-Elite-8T foresees that a low return will occur, it will increase the Target automatically as an effort to increase the return temperature. See Return Sensor Wiring on page 10.

MINIMUM RETURN

Adjustable Off, from 80°F/27°C to 140°F/60°C

Default: 120°F/49°C

Hold Button: MENU/Min. Return

in Heating only

- The Minimum Return is the critical temperature at which the return should be above. Normally, this setting is provided by the boiler manufacturer or the system engineer.
- The SQ-Elite-8T will use that value as a guide. It will start to add additional stages if it foresees that the RTN temperature will drop below the Min. Return. During that period, it will display "Hold Return at 120°F" in the Display Message Line to indicate that the SQ-Elite-8T is sequencing boilers to protect the return from dropping below the Minimum Return.
- Most condensing boilers will run more efficient with cooler return temperatures. In this case, select the Off option on the Minimum Return to allow the monitoring of the return on the display without sequencing the boiler stages.



RETURN LAG

Adjustable from 0 to 30 minutes

Default: 2 minutes
in Heating only

Hold Button: MENU/Min. Return/Return Lag

- It is the time it takes for the system return to change after sequencing the stages.
- Initially, adjust this value to equal the Reaction Time. Then, in extreme cold weather monitor the return making sure it is about 10°F above the Minimum Return setting and adjust it if needed.



SYSTEM SETTINGS

Hold Button: MENU/<System Settings>

The System Settings menu provides access to adjusting and fine-tuning the system for enhanced comfort and better fuel savings. The SQ-Elite behaves differently based on the selected Control Modes (see Startup Settings 17).

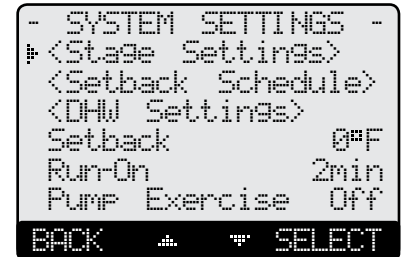

PROGRAM CHANGE SETTINGS

To be able to change the SQ-Elite settings the Program/Run Switch must be set to Program. The switch is located under the Enclosure Wiring Cover for security. The Enclosure Wiring Cover can be securely closed using a padlock.



STAGE SETTINGS

Button: MENU/<System Settings>/<Stage Settings>

REACTION TIME

Adjustable from 1 to 10 minutes

Default: 2 minutes

Hold Button: MENU/<System Settings>/<Stage Settings>/Reaction Time in PID Logic only

- It is the amount of time it takes a single stage to affect the system.
- After the SQ-Elite-8T turns on a stage trying to meet a set point, it will not turn on another stage until the Reaction Time has elapsed.
- To determine the optimum time, in a heating system start with a hot system. On the other hand, in a cooling system start with a cool system. Turn on a single stage and calculate how long it takes until the system begins to respond to that stage. That period should be set as the Reaction Time (See PID operation 6).



PURGE DELAY

Adjustable from 0.0 to 10.0 minutes

Default: 0.0 minutes

Hold Button: MENU/<System Settings>/<Stage Settings>/Purge Delay in PID Logic only

- Most large units must go through a purge cycle before they are brought on line.
- When the SQ-Elite-8T activates a unit (the lowest stage on a unit), it does not start to calculate its output until the Purge Delay is over. This allows the unit to fully come on line and to begin producing output.
- The Purge Delay helps prevent short cycling of a newly activated unit. Once the lowest unit stage is activated, it MUST run through the entire Purge Delay period (See PID operation on page 6).
- The minimum Purge Delay setting MUST be set to the time required by the units manufacturer specification.



MINIMUM RUNTIME

Adjustable from 1 to 60 minutes

Default: 2 minutes

Hold Button: MENU/<System Settings>/<Stage Settings>/Min Runtime in PID Logic only

- This is the minimum amount of time any stage will run (See PID operation on page 6).
- For the lowest stage of a unit, the Minimum Runtime starts after the purge cycle.
- This timer does not apply to the last stage online. The Last Stage Hold applies in that case.
- Initially, set the Minimum Runtime to half the Reaction Time.
- If System tends to overshoot, reduce the Minimum Runtime. If boilers tend to short cycle, increase Minimum Runtime.



STANDBY DELAY

Adjustable from 1 to 60 minutes

Default: 10 minutes



Hold Button: MENU/<System Settings>/<Stage Settings>/Standby Delay in PID Logic only

- The Standby Delay only applies to units in Standby Mode. See Mode on page 32.
- A Standby unit can only be activated after all the units in Auto Mode have had all their stages on running for the full Standby Time.
- Standby units are used as a backup in extreme load conditions. A Standby unit can never be a Lead unit.
- The full Standby Delay must always elapse regardless of what happens to the system temperature. Therefore, shorter Standby times will result in smoother set point operation in extreme conditions. Longer Standby times may prevent a Standby unit from starting if the other units can eventually meet the load or if the load decreases.
- When setting the Standby Delay, remember that it will be added to the Reaction Time for the first stage on the first standby unit. The following stages start time will rely on Pre-Purge and Reaction Time only.

LAST STAGE HOLD

Adjustable from 0°F/0°C to 30°F/17°C

Default: 5°F/3°C



Hold Button: MENU/<System Settings>/<Stage Settings>/Lst Stg Hld in PID Logic only

- The Last Stage Hold prevents short cycling of the Lead Stage during low load conditions where the system might have a load that is significantly less than the output of one stage. When the SQ-Elite-8T brings on the Lead Stage, the Set Point is quickly exceeded, and the Lead Stage is turned off. To prolong the run time during this type of condition, use the Last Stage Hold setting.
- In heating, the SQ-Elite-8T will allow the system temperature to exceed the Set Point by the number of degrees selected, before the Lead Stage is turned off. In cooling, the SQ-Elite-8T will allow the system temperature to rise above the Set Point by the number of degrees selected, before the Lead Stage is turned off (See PID operation on page 6).
- For example, with a Set Point of 160°F and a Last Stage Hold setting of 10°F, the Lead Stage boiler will remain on, until the Set Point reaches 170°F. During that period, the display will show "Hold Until 170°F" then, the lead stage will turn off

THROTTLE RANGE

Adjustable from 2°F/1°C to 20°F/11°C

Default: 2°F/1°C



Hold Button: MENU/<System Settings>/<Stage Settings>/Throttle in OSS Logic only

- The Throttling Range sets a temperature band around the Set Point that controls when stages will be turned on or off.
- For example, in the OSS Control Mode, no stages will be activated until the temperature falls one full Throttling Range below the Set Point. A second stage will be activated when the temperature falls to two full Throttling Ranges below the Set Point, and so on, with one extra stage being turned on for every throttling range below the Set Point the System temperature reaches.
- Stages will be turned off as the temperature rises toward the Set Point using one full throttling range as a differential between stages.
- The last stage to be turned off will be allowed to exceed the Set Point by a full throttling range before it is turned off. This helps to prevent the last stage from short cycling when the load is low or when the stage is oversized (See OSS operation on page 6).

Throttling Example in Heating Mode

Set Point = 180°F

Throttling = 5°F

4 Boiler Stages, A, B, C, and D

Temperature	Calculation	Falling Temperature		Rising Temperature	
		Stage Turned On	Stages On	Stage Turned Off	Stages On
185°F	180 + (1)THR	---	None	A	None
180°F	180 - (0)THR	---	None	---	A
175°F	180 - (1)THR	A	A	B	A
171 to 174°F	---	---	A	---	A,B
170°F	180 - (2)THR	B	A,B	C	A,B
166 to 169°F	---	---	A,B	---	A,B,C
165°F	180 - (3)THR	C	A,B,C	D	A,B,C
161 to 165°F	---	---	A,B,C	---	A,B,C,D
160°F	180 - (4)THR	D	A,B,C,D	---	A,B,C,D

LEAD SETTINGS

Hold Button: MENU/<System Settings>/<Stage Settings>/<Lead Settings>

The lead menu is to help in selecting the Lead unit and the type of rotation appropriate for the system.

LEAD BOILER

Depending on the number of stages

Default: The first set of stages

Hold Button: MENU/<System Settings>/<Stage Settings>/<Lead Setting>/Rotate Mode

- The Lead Unit's lowest stage will always be the first stage brought on when there is a call for output. As more output is needed, additional stages are added.
- The Lead Unit is always shown on the main display in brackets.
- In a 2-Stage system (see Burner Type in the Startup section on page 19), the display will show the two Lead Unit stages bracketed <AB>. In a 3-Stage system, the display will show the three Lead Unit stages bracketed <ABC>, and so on.
- If a pump or a valve is selected as the Boiler Output in the Startup menu (see page 19), the pump or valve letter will be skipped from the number of stages. See example to the right. The missing stage C and F represent the Unit Valve or Pump.
- The Lead Unit can be rotated based on the Rotation Mode selected. (See next setting)



No Pump or Valve stages



With Pump or Valve stages



ROTATE MODE

Adjustable Time (from 1 hr to 999 hrs), Manual, FOFO Default: Time (24Hours)

Hold Button: MENU/<System Settings>/<Stage Settings>/<Lead Setting>/Rotate Mode

- The Lead Unit is the first unit brought on when output is required.
- The Lead Unit can be rotated automatically, manually, or based on First-On/First-Off (FOFO). The automatic rotation is recommended for most applications.
- The current Lead Unit is shown in brackets on the main display.
- Only units that are set to Auto Mode can be Lead. Therefore, not all the units may be available when manually selecting a new Lead Unit.
- If Time is selected, a second screen will allow the adjustment of the Auto Rotate Period. If 24 Hours (default setting) was selected, the first rotation will take effect after 12 hours if the Time was not set. However, if the Time was set, the rotation will always take place at 2:00AM. The following rotations will take place every 24 hours thereafter.
- If Time Rotation was set to other than 24 hours, the rotation timer will start from the moment the setting is changed.
- If First-On/First-Off (FOFO) is selected, the concept will follow this example; if A is the lead, the starting sequence of the units will be A, B, then C. When the de-energizing of the stages starts, it will turn off A, B, Then C. Then, stage D will be the new lead for the next load.



If Time Rotation is selected

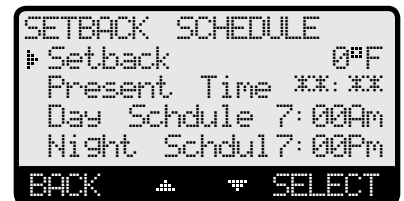

SETBACK SCHEDULE

Hold Button: MENU/<System Settings>/<Stage Settings>/<Setback Schedule>

This menu provides the Setback and Boost on Day/Night Schedule. It will only be available when Shutdown or Tstat are selected as the Startup External Input option.

SETBACK

Adjustable from 0°F/0°C to 80°F/44°C

Default: 0°F/0°C

Hold Button: MENU/<System Settings>/<Stbck Schdle>/Setback in Day/Night Schedule

Hold Button: MENU/<System Settings>/Setback

in External Signal

- The Setback feature can be used to provide the SQ-Elite-8T with a lower temperature Set Point in heating or a higher Set Point in cooling when less load is required during the night or on the weekends when the building is not occupied, but output is still required.
- The new Set Point will appear on the main display indicating this condition "Setback to 160°F".
- For example, if in heating the calculated temperature is 180°F and the Setback is 20°F, then when in Setback, the SQ-Elite-8T will hold a Set Point of 160°F (180°F - 20°F).
- After selecting a value in Setback, you will be directed to the Boost menu.



BOOST

Adjustable from 0°F/0°C to 80°F/44°C

Default: 0°F/0°C

Hold Button: MENU/<System Settings>/Setback/Boost

- This feature allows a building to either warm up or cool down quickly after a Setback period to bring the building to the desired temperature faster.
- The Boost temperature will be the number of degrees to be added in Heating or subtracted in Cooling from the Target.
- The new Set Point will appear on the main display indicating this condition "Boost to 190°F".
- Using the previous example, if the Target was 180°F and the Setback was 20°F and the Boost was 10°F for 30 minutes, after the setback period, the Boost will change the target to 190°F for a period of 30 minutes.



BOOST PERIOD

Adjustable from 0 to 120 minutes

Default: 30 minutes

Hold Button: MENU/<System Settings>/Setback/Boost/Boost Period

- This will determine the length of time the system will receive Boost.
- If External Signal was selected as the Setback Mode, the Boost will start when the switch from Setback to normal operation takes place and will continue for the full Boost Period. An example would be if the Boost Period was set to 30 minutes and the shorting of the Setback terminals has ended at 7:00Am, the Boost will start at 7:00Am and will terminate at 7:30Am where the control will resume normal operation.
- If Day/Night Schedules were available, the Boost will start a full Boost Period prior to the switch from Night setback to Day normal operation. If the Day was set to start at 7:00Am, the Boost Period was set to 30 minutes, the Boost will start at 6:30Am and terminate at 7:00Am.



Avoiding Conflicting Boiler Limits

- The temperature limits set on the boilers MUST be set considerably higher than the SQ-Elite-8T's Set Point for the reasons detailed below.
- The SQ-Elite-8T sensor is located in a common header some distance from the boilers. As the temperature rises in the header and before reaching the sensor location, energy is dissipated. Therefore, the temperature in the header could be lower than that registered by boiler sensors.
- In addition to the normal drop experienced between the boiler's temperature and that read by the SQ-Elite-8T sensor, the Last Stage Hold setting must be accounted for. The boiler limit must be set above the Set Point PLUS the Last Stage Hold PLUS the normal drop experienced in the piping.
- Using the previous example of a 10°F Last Stage Hold with a 160°F Set Point, the boilers' limits must be set enough over 170°F to prevent the boilers' internal limits being reached. In this situation, the boiler high limit should be set at approximately 180°F to prevent the difference in boiler temperature vs. header temperature from causing erratic operation.

⚠ WARNING

The temperature limits set on the boilers must be higher than the SQ-Elite Set Point. Read the section at left for details that will prevent erratic system operation.

DAY/NIGHT SCHEDULES

Hold Button: MENU/<System Settings>/<Setback Schedule>/Day Schedules

- The SQ-Elite has two levels of heat or cool. The Day level is used when a building is occupied and people are active.
- The Night (Setback) level is used when a building is not occupied, or when people are sleeping. This setting reduces the calculated temperature in Heating and increase it in Cooling by the Setback setting based on the provided schedule. In Heating, if the Day calculated water temperature was 150°F and the Setback was 20°F, the Night Schedule will run at $(150°F - 20°F) = 130°F$.
- If the Boost feature is being used, it uses the Day Schedule as a Boost ending point. That is, if the Day Schedule is set to start at 6:00AM, the Boost was set to 10°F, and the Boost Period was 30 minutes, the Boost will start at 5:30AM. Then, when in Boost, SQ-Elite-8T will raise the calculated water temperature by the Boost amount. Using the previous example, at 5:30AM the SQ-Elite-8T will raise the calculated water to 170°F $(150°F + 20°F)$ until 6:00AM where it will drop back to the normal calculated temperature of 150°F.



SET PRESENT TIME

Hold Button: MENU/<System Settings>/<Setback Schedule>/Present Time

Hold Button: MENU/<Maintenance>/Present Time

- The Time is used for Day/Night Schedule and History graph.
- Adjust the time by selecting Time from the menu and then scrolling through the hours followed by the minutes. If hours are to be set to PM, scroll through the AM hours to reach the PM hours.



▲ ALERT

Remember that the battery is used as a time backup. If no power is supplied to the SQ-Elite, the battery will die in three months and time clock values will be lost. Thus, DO NOT power down the control during off-season.

DHW SETTINGS

Hold Button: MENU/<System Settings>/<DHW Settings>

- A DHW call can be initiated by shorting the DHW input terminals, 33 and 34. In addition, using a Heat-Timer temperature sensor on the same terminals instead of a dry-contact input will add the DHW Set Point and Differential control capability.
- On a DHW call, the SQ-Elite-8T will raise the Target to either 200°F or the Maximum Target, whichever is lower.
- The SQ-Elite-8T provides three levels of DHW pump operation. The first is when Primary/Secondary is selected as the DHW Piping from the Startup Menu on page 18. This option will provide no DHW Priority. And, if there was a DHW call during the Summer or when the outdoor temperature is above the Outdoor Cutoff, both the DHW Pump and the System relays will energize. Upon the termination of the DHW call, the DHW Pump relay will de-energize leaving the System relay energized for the Run-On delay.
- If Parallel was selected as the DHW Piping from the Startup menu on page 18 and the Season was set to Winter while the DHW Priority Timer was set to NO, a DHW call will keep the System relay energized in addition to energizing the DHW Pump relay. Upon termination of the DHW call, the DHW Pump relay will de-energize leaving the System relay on.
- However, in Winter, if the DHW Priority Timer was set to a value other than NO, a DHW call will de-energize the System relay and energize the DHW Pump relay. This will remain for the period of the DHW Priority Timer setting or until the DHW call terminates, whichever is sooner. If the DHW call was still active after the DHW Priority Timer elapses, the System relay will energize for the remaining of the DHW call period.

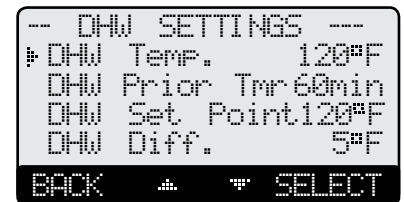

DHW PRIORITY TIMER (AVAILABLE WITH PARALLEL DHW PIPING)

Adjustable NO, 1 to 120 minutes

Default: No

Hold Button: MENU/<System Settings>/<DHW Settings>/DHW Prior. Timer in Parallel

- The DHW Priority Timer is only available when DHW Piping is set to Parallel (See page 18). It provides the user with the capability of selecting the DHW Priority period. If NO was selected, a DHW call will energize the DHW pump relay without affecting the System Pump operation. That is, when in Summer or Outdoor Cutoff, a DHW call will energize only the DHW Pump relay leaving the System relay off.
- In Winter, if the DHW Priority Timer was set to a value other than NO, a DHW call when the outdoor temperature is below the Outdoor Cutoff will cause the System relay to de-energize and the DHW Pump relay to energize for the period of the DHW Priority Timer or until the DHW call expires, whichever happens sooner. If the DHW call did not expire within the Priority period, then the System relay will energize.



DHW SET POINT (REQUIRES AN OPTIONAL DHW TEMPERATURE SENSOR)

Adjustable 100°F/38°C to 200°F/93°C

Default: 120°F/49°C

Hold Button: MENU/<System Settings>/<DHW Settings>/DHW Set Point

- This is the desired DHW temperature setting at which the DHW Pump relay will de-energize when reached.
- The SQ-Elite-8T can accept a DHW call in two ways. An aquastat can provide a dry contact closure to terminals 33 and 34 is the first option.



- The second option will be connecting a Heat-Timer temperature sensor (HT #904250-00) for immersion in a 3/8ID well (HT #350147-00 or 904011-00) will offer the capability of adjusting the DHW Set Point and Differential through the SQ-Elite-8T easy to follow menu (See page 29). In addition to being able to view and log DHW temperature history.

DHW DIFFERENTIAL

Adjustable 5°F/3°C to 80°F/44°C

Default: 10°F/6°C

Hold Button: MENU/<System Settings>/<DHW Settings>/DHW Diff.

- This represents the number of degrees the DHW temperature can drop from the DHW Set Point before a DHW call can be recognized and the DHW Pump relay energized.
- A large DHW Differential will result in oscillation in the DHW temperature. However, a small DHW Differential will have a tighter control over the DHW temperature but might result in boilers coming on frequently for short periods to satisfy the DHW Set Point and Differential settings.



PUMP, VALVE, AND COMBUSTION AIR DAMPER OPERATION

- The SQ-Elite-8T controls multiple relays each controlling different types of equipment. In addition to the control of the boilers or cooling units, it can control, the primary system pump, unit pumps or valves, a DHW pump, and a combustion air damper. The operation of those relays depends on the Startup and System Settings.

RUN-ON

Adjustable 0 to 60 minutes

Default: 2 minutes

Hold Button: MENU/<System Settings>/Run-On

- The Run-On applies to all pumps, valves and dampers. It is the additional time a pump, valve, or a combustion air damper relay will run after the output unit relays has de-energized. For pumps and valves, it is used to dissipate the excess energy from the heating or cooling system into the building. For a combustion air damper, it brings in enough fresh air for the next boiler fire up.
- The Run-On time should be set based on the size and type of the equipment. A boiler with low water content will need a longer Run-On than a boiler with more water content.



PUMP EXERCISE

Adjustable Off, On

Default: Off

Hold Button: MENU/<System Settings>/Pump Exercise

- The SQ-Elite-8T provides an option to exercise pumps for 10 seconds when not used for seven days. This option reduces pumps' impellers locking after a long off-season period.



MAINTENANCE

Hold Button: MENU/<Maintenance>

The Maintenance menu gives access to sensor and output trimmings in addition to viewing the Startup configuration settings as well as sensor History.



▲ ALERT

To be able to change the SQ-Elite settings the Program/Run Switch must be set to Program. The switch is located under the Enclosure Wiring Cover for security. The Enclosure Wiring Cover can be securely closed using a padlock.

SYSTEM & OUTDOOR SENSOR TRIM

Adjustable -20°F/-10°C to +20°F/+10°C

Default: 0°F

Hold Button: MENU/<Maintenance>/System Trim

Hold Button: MENU/<Maintenance>/Outdoor Trim

Hold Button: MENU/<Maintenance>/Return Trim

Hold Button: MENU/<Maintenance>/DHW Trim



- The Heat-Timer thermistor type sensors are very accurate, and normally require no calibration. However, sometimes it may be desirable to make small adjustments to the displayed value.
- Do not use the Trim setting to make the Outdoor sensor match the one reported on the radio or TV. Outdoor temperature can vary widely over a broadcast range.

HISTORY

Hold Button: MENU/<Histories>

The SQ-Elite-8T provides users with a graphical history of the System, Outdoor, DHW, and Return sensors for the previous 24 hours. The temperatures are sampled every 12 minutes. That is, readings of temperatures are recorded and stored every 12 minutes for the last 24 hours.

- To view the values of a specific period, use the two middle buttons to scroll to that time and read the upper left temperature.
- The first screen will be the System Temperature History. By clicking on the Next button, you will be able to view the Outdoor Temperature History, then, the Return History followed by the DHW History.

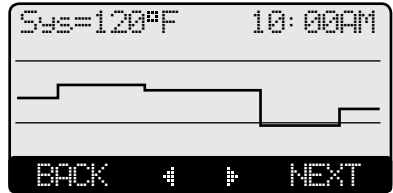

CONFIGURATION

Hold Button: MENU/<Maintenance>/<Configuration>

- This menu provides a consolidated view of the Startup settings.
- Additional control settings will be available by selecting the NEXT option.



DISPLAY AND BUTTONS

The SQ-Elite display layout provides a variety of information that gives an immediate picture of the operation status. The display shows four heating or cooling units at a time. The two middle buttons scrolls the screen to view any additional units. Moreover, all the information is brightly displayed. It can be viewed in brightly or dimly lit rooms.

- The buttons' functionality changes based on the screen and menu level. The buttons' functionality is displayed on a dark background on the screen's bottom line.
- The second line from the top is the Message Display Line. In normal operation it displays the Target Set Point. If a Return sensor was connected, the Target display will be alternating its value with the Return temperature. When the control is to display a status message, the message will replace Target and Return temperatures. See Display Messages on page 31.



The two middle buttons functions are as follows:

- The Horizontal arrows are to scroll through the available stages.
- The Vertical arrows are to scroll through the menu functions when in menus or to change values of settings when in its specific screen.

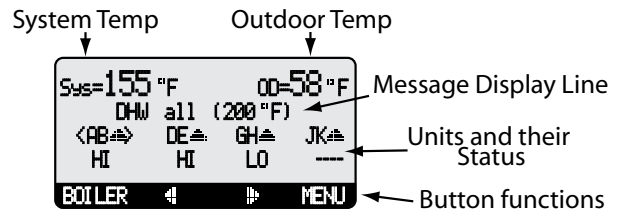

DISPLAY OUTPUT STATUS

The SQ-Elite-8T unit sequencing status gives immediate access to each unit status. The following list shows all possible boiler status:

- <AB> Two-Stage unit and Unit AB is the Lead in sequencing. (Brackets indicate Lead Stage).
- --- Unit is de-energized. The unit Mode is set to Auto.
- STB Unit is de-energized. The unit Mode is set to Standby.
- HI Unit highest stage is active. The unit Mode is set to either Auto or Standby.
- MED Unit Middle stage is active. Available in Three-stage units only. The unit Mode is set to either Auto or Standby.
- MHI Unit Middle High stage is active. Available in Four-stage units only. The unit Mode is set to either Auto or Standby.
- MLO Unit Middle Low stage is active. Available in Four-stage units only. The unit Mode is set to either Auto or Standby.
- LO Unit Lowest stage is active. The unit Mode is set to either Auto or Standby.
- ON All Unit Stages are set to ON.
- OFF All Unit Stages are set to OFF or unit does not exist.
- C/E Unit on Extension panel is not communicating back to the SQ-Elite-8T.
- ☰ Unit Pumps are being controlled by the SQ-Elite-8T.
- ☷ Unit Valves are being controlled by the SQ-Elite-8T.

DISPLAY MESSAGES

The SQ-Elite-8T normal display layout reserved the second line for message indications. The following is a list of the most common Message Display Line information:

- Summer The control is set to Summer. No heat is active.
- Winter The control is set to Winter. No cooling is active.
- Outdoor Cutoff The Outdoor temperature is above the Outdoor Cutoff in heating or below it in cooling.
- Shutdown Active The Shutdown Terminals are Shorted. No heating or cooling units will be active.
- Shutdown by EMS The EMS is below 2mA or above 22mA
- DHW Call (171 °F) There is a DHW (Domestic Hot Water) call. The SQ-Elite-8T will Raise system Set Point to the indicated temperature. DHW increases calculated temperature to 200°F or Max Water Temperature, whichever is lower.
- Holding Return at 110°F Return sensor is reading less than the Minimum Return. SQ-Elite-8T is trying to raise return to 110°F.
- Holding Until 150°F The Lead boiler is in Last Stage Hold. This example shows that the lead stage will turn off when system temperature reaches 150°F.
- Waiting for Comb. Prove The System or Combustion Air Damper relay is ON and the prove terminals are open before the lead boiler relay can energize.
- SYS Prove Failure After boilers have run for a while, Prove signal was opened. The boiler relays will de-energize. However, the System relay will remain energized.

BOILER/C.UNIT SETTINGS

Button: BOILER/

- In most installations, all active unit adjustments are the same, but each can be configured differently if desired.
- When the BOILER or C.UNIT button is depressed, the Unit A Settings menu will be shown.
- Make all the appropriate settings for Unit AB (if 2-Stage was selected as the Burner Type from the Startup on page 19).
- Then select the Next Stage option from the menu to bring up the Boiler CD Settings menu and make all the settings. Continue until all boilers have been set.
- If a SQ-Elite-EXT is connected to the SQ-Elite-8T, scrolling through stages using the Next and Prev menu options will scroll through the SQ-Elite-EXT stages as well.



⚠ ALERT

To be able to change the SQ-Elite settings, the Program/Run Switch must be set to Program. The switch is located under the Enclosure Wiring Cover for security. The Enclosure Wiring Cover can be securely closed using a padlock.



MODE

Auto, Standby, Off, On

Default: Auto

Button: BOILER/Mode

- The SQ-Elite-8T only controls any unit set to Auto or (after a delay) those set to Standby.
- Any output without an active unit connected must be set to Off.
- The following list describes the MODE options:



- Auto** - The SQ-Elite will control the unit's operation to maintain the desired Set Point. Only units set to Auto can be lead unit.
- Standby** - These units can only be activated when all units in Auto have been at HI for an adjustable Standby delay period. Standby units are generally used as a backup in extreme load conditions. Note that, a Standby unit cannot be a lead unit. Standby Delay is only available in PID mode.
- Off** - Any output unit not connected to a physical unit should be set to Off. The Off Mode can also be used to disable units that are being serviced.
- On** - The On Mode should only be used when testing a unit. The On Mode overrides the *PROVE* and *SHUTDOWN* inputs. Once set to On the unit will immediately start all of its stages.

RUNTIME

Clear

Button: BOILER/RunTime

- The RunTime provides an accumulative hourly run for the selected unit.
- The RunTime for a specific unit can be reset to zero by pressing the middle two buttons.



TROUBLESHOOTING

TEMPERATURE INPUTS

Display shows Sensor OPEN

Check the sensor is connected and the wires are continuous to the SQ-Elite-8T. Finally follow the procedure for Incorrect Temperature Display.

Display shows Sensor SHORT

The SQ-Elite-8T sees a short across the input terminals. Remove the wires from the the sensor terminals. The display should change to read OPEN. If it doesn't, the SQ-Elite-8T may be damaged.

Display shows an Incorrect Temperature Display

Remove the wires from the sensor terminals. The display should change to read OPEN. If it doesn't, the SQ-Elite-8T may be damaged. Take an ohm reading across the detached sensor wires. Take an ohm reading across the detached sensor wires. The ohm reading should correspond to the Temperature sensor Table. If it does not, the sensor may be damaged.

Return Sensor does not Display Temperature

Check the sensor is connected and the wires are continuous to the SQ-Elite-8T. Finally follow the procedure for Incorrect temperature display.

CONTROL OPERATION

Too Much Heat

Check if the control has any of the following conditions:

- **Domestic Hot Water call** - The SQ-Elite-8T will raise the temperature of the system to either 200°F or Maximum Target on a DHW call.
- **Reset Ratio and Offset** - If excessive heat occurs only in certain weather conditions, adjust the Reset Ratio and Offset (See Understanding Operating Concept on page 5). If excessive heat occurs year round, reduce the Offset.
- **Unit Mode Settings** - The SQ-Elite-8T will only sequence boilers with a Mode set to Auto or Standby. Check to if any boiler stage is set to On.
- **Control Settings** - The Last Stage Hold will allow only the Lead boiler to exceed the set point. If the setting is too high, and only the Lead boiler is on, the system can over heat. Reduce the Last Stage Hold setting. This will mostly occur in mild weather.

Too Little Heat

Check if the control has any of the following conditions:

- **Reset Ratio and Offset** - If reduced heat occurs only in certain weather conditions, adjust the Reset Ratio and Offset (See Understanding Operating Concept on page 5). If reduced heat occurs year round, increase the Offset.
- **Setback and Day/Night Schedule** - If reduced heat occurs only during specific hours, check the Day/Night Schedule and the Setback, Boost, and Boost Period values. Either reduce the Setback or Boost settings or change the Day and Night Schedules.
- **Boiler Mode Settings** - The SQ-Elite-8T will only modulate boilers their mode is set to Auto or Standby. Check if any boiler stage is set to Manual, Off, or Standby.

Units are Short-Cycling

- **Minimum Runtime** - Increase the Minimum Runtime only if all units tend to short-cycle.
- **Last Stage Hold** - Increase the Last Stage Hold only if the lead unit tends to short-cycle.

System is Overshooting or Undershooting

- **Reaction Time and Minimum Runtime** - If the system is overshooting or undershooting, adjust Minimum Runtime or the Reaction Time. That depends on if the stages are brought on fast and were not allowed to turn off until the Minimum Runtime elapsed. Or, the stages were brought on slowly, however, were allowed to turn off quickly.
- **PID vs OSS** - If the application the system is used on requires fast response that the normal PID mode cannot provide, try using the OSS mode and adjust the Throttle Range according to the system requirements.

Temperature Sensor Chart

TEMPERATURE (in Degrees °F)	Value (in Ohms)
-30	117720
-20	82823
-10	59076
0	42683
10	31215
20	23089
25	19939
30	17264
35	14985
40	13040
45	11374
50	9944
55	8714
60	7653
70	5941
80	4649
90	3667
100	2914
110	2332
120	1879
130	1524
140	1243
150	1021
160	842
170	699
180	583
190	489
200	412
210	349
220	297
230	253
240	217
250	187

MULTIPLE BOILERS WITH PUMPS PIPING/WIRING DIAGRAMS

The SQ-Elite sequencing 4 single-stage boilers and their boiler pumps. The boilers are piped in Reverse Return on the primary loop. The System output is controlling the System Pump.

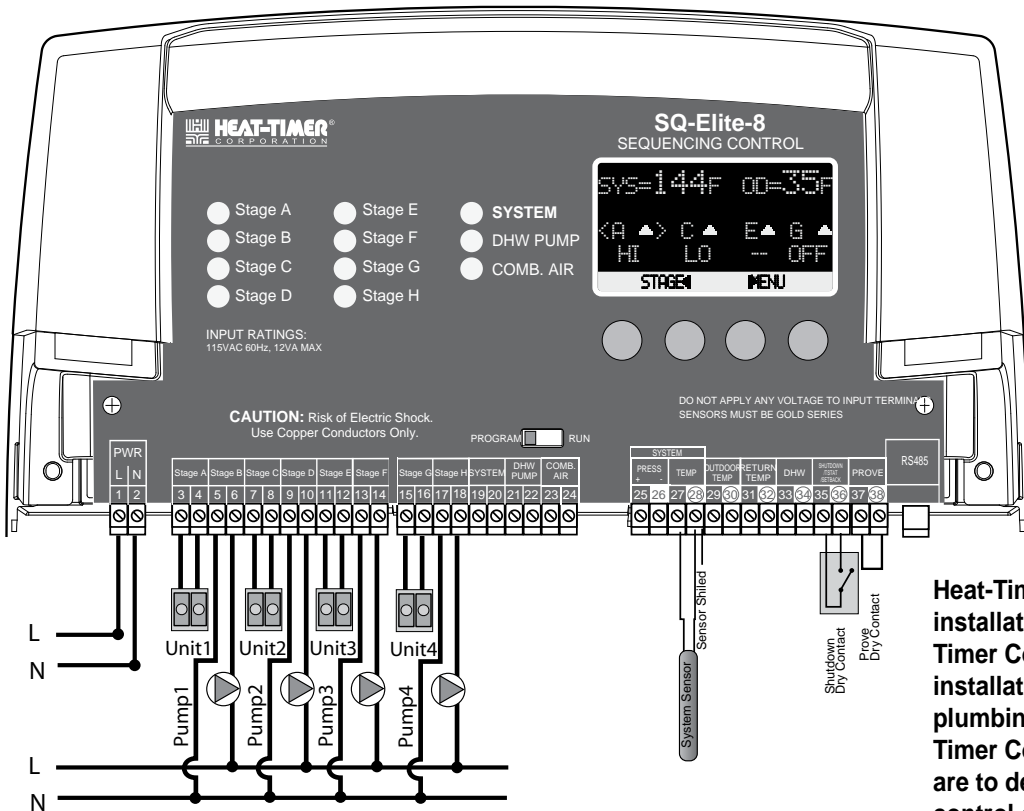
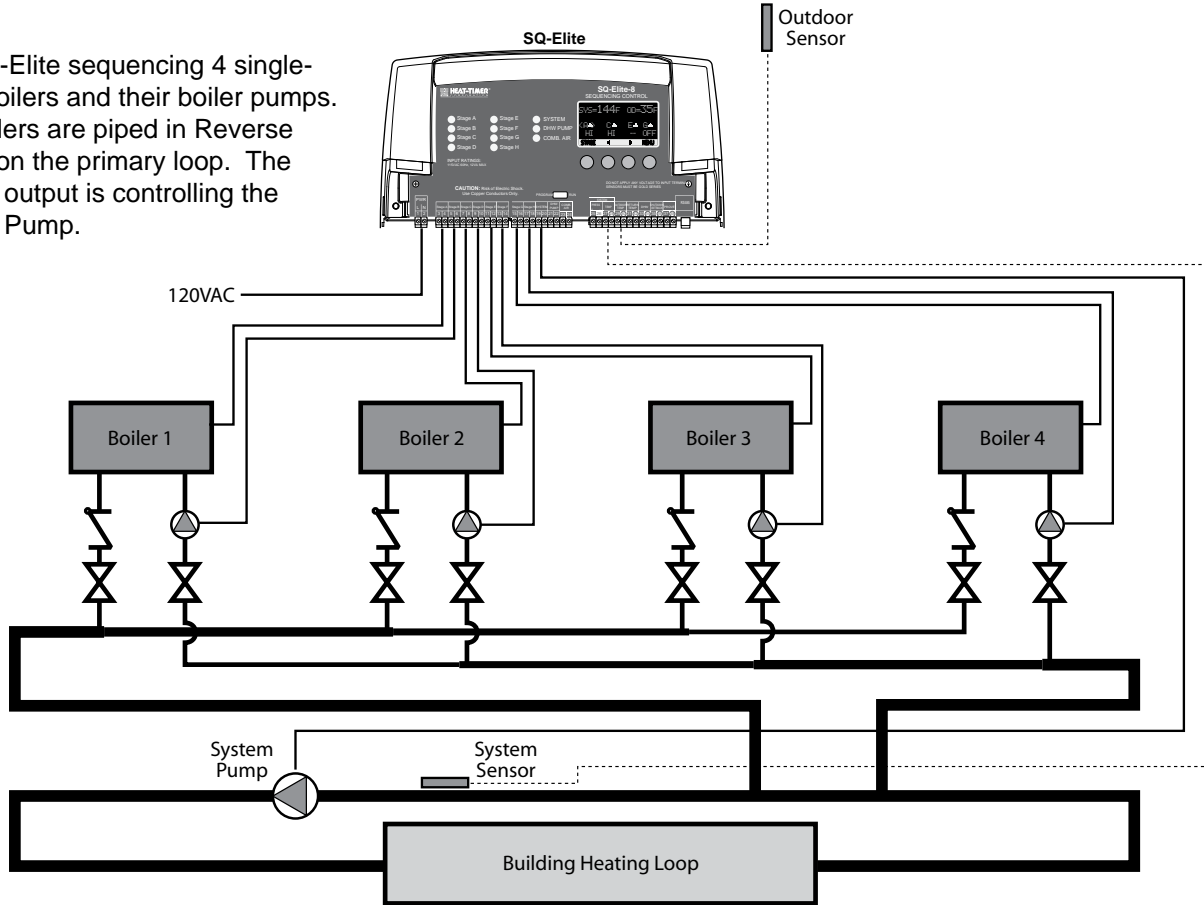

Heat-Timer Corp. is aware that each installation is unique. Thus, Heat-Timer Corp. is not responsible for any installation related to any electrical or plumbing diagram generated by Heat-Timer Corp.. The provided illustrations are to demonstrate Heat-Timer Corp.'s control operating concept only.

USER MENU SEQUENCE

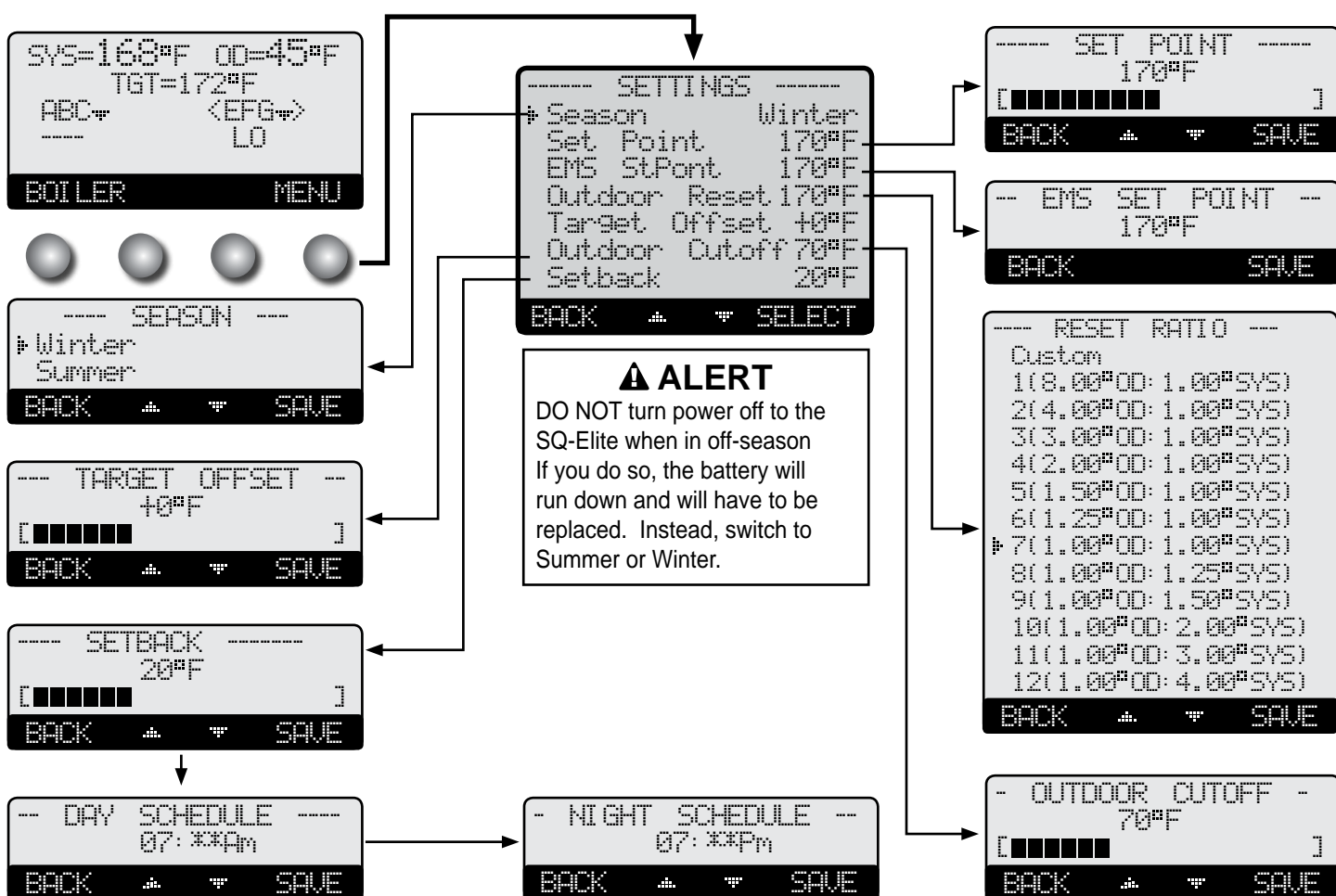

Operating users have a simplified menu that can be accessed by clicking the Menu button. Installer menu will have the same settings in addition to Startup and more advanced operation settings. The installer menu can be access by holding down the Menu button for three seconds or more.

PROGRAM CHANGE SETTINGS

To be able to change the SQ-Elite-8T settings the Program/Run Switch must be set to Program. The switch is located under the Enclosure Wiring Cover for security. The Enclosure Wiring Cover can be securely closed using a padlock.



SEASON

Button: MENU/Season

Winter, Summer

Default: Winter

- When in Heating mode, the SQ-Elite-8T will turn all boiler relays off when it is in Summer setting. The Message Display Line will read *Summer* to show status.
- When in Winter, the SQ-Elite-8T will activate the Sys relay whenever the Outdoor temperature falls to or below the Outdoor Cutoff setting. In addition, it will begin heating whenever the System temperature falls below the Set Point. The Message Display Line will not display any season information.
- If the control was set to Cooling, the SQ-Elite-8T will turn on the cooling units when it is set to Summer. However, when it is set to Winter, The Message Display Line will read *Winter* to show status.



SET POINT (NOT ADJUSTABLE IN EMS MODE)

Adjustable -10°F/-23°C - 230°F/110°C

Default: 70°F/21°C

Button: MENU/Set Point

In Set Point or EMS 4-20mA



- The Set point is the temperature value the SQ-Elite-8T will use to control the system.
- The SQ-Elite-8T will add, subtract, or hold the stages of the heating or cooling units to maintain the system temperature around the Set point.
- The system temperature can be expected to fluctuate around the set point. The amount of fluctuation depends on the System Settings and Stage Settings.
- If the EMS Mode was Enabled, the Set Point will be set by the EMS/BMS system and will be available to be only read.
- The range of Set Point in the EMS is set in the Startup menu at 4mA and 20mA.
- Any reading below the 2mA or above 22mA will indicate a "Shutdown by EMS" message on the Message Line.

RESET RATIO

Custom, 1(8.00°OD : 1.00°Sys) to 12 (4.00°OD : 1.00°Sys)Default: 1(1.00°OD : 1.00°Sys)

Button: MENU/Outdoor Reset/Reset Ratio

In Outdoor Reset Only

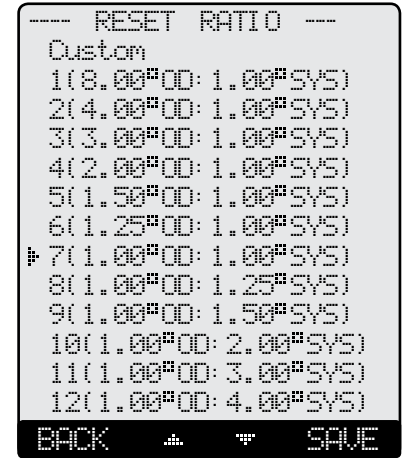

- The Reset Ratio applies only to Heating applications.
- The Reset Ratio determines how the System water temperature will vary with the outside temperature. With any of the ratios, the colder it becomes outside, the hotter the temperature of the system water. (See Understanding Operation Concept on page 5)
- With a 1.00 (OD):4.00 (SYS) ratio, the System water temperature (SYS) will increase rapidly as the outside temperature falls, hitting the Maximum of 240°F at 35°F outside temperature. With a 4.00 (OD):1.00 (SYS) ratio, the System water temperature (SYS) will increase slowly as the outside temperature falls. Even at -30°F, the system water will only be 125°F, and at 22°F outside, the system water will be 112°F. Such a low Reset Ratio might be used with radiant floor heating applications.
- With most baseboard heating applications, a 1.00 (OD):1.00 (SYS) setting is a good place to start. With a 1.00 (OD):1.00 (SYS) ratio, for every degree the outside temperature falls, the system water temperature is increased one degree.
- If required: **Adjust the RESET RATIO in cold weather.** If the ambient building temperatures are too cold in cold weather, move the ratio to a higher selection. That is, if 1.00 (OD):1.00 (SYS) was initially selected, change the selection to 1.00 (OD):1.25 (SYS). If the building temperatures are too warm in cold weather, move the ratio to a lower selection. That is, if 1.00 (OD):1.00 (SYS) was initially selected, change the selection to 1.25 (OD):1.00 (SYS).

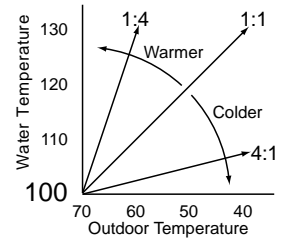

CUSTOMIZED RESET RATIO

Button: MENU/Outdoor Reset/Reset Ratio/Custom

- For situations where the available reset ratios do not provide the perfect building heat-loss equilibrium, the customized option can be used by selecting Custom from the Reset Ratio menu option.
- It provides the user with the capability of assigning two points on the reset ratio diagram and use the line that connects those two points as the customized reset ratio curve. Each of the two points will need a specific System and Outdoor Temperature to identify it on the diagram.
- To Set the first point, specify Sys Temp 1 and OD Temp 1. Then, specify Sys Temp 2 and OD Temp 2, to set the second point on the curve. The two points can be anywhere on the line, not necessarily at the ends.
- The chart shows an example of a customized curve 6(OD):5(SYS) that does not exist in the standard curve options. If the outdoor temperature reaches 30°F, the system target will be 145°F.
- Remember that the Offset, Min Target, and Max Target apply to all reset ratios including the customized reset ratio ones.

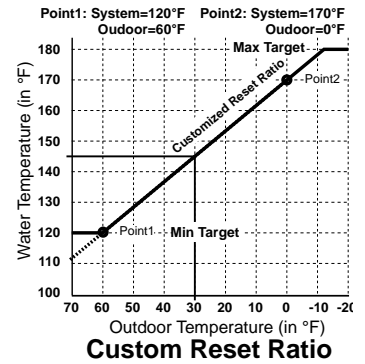
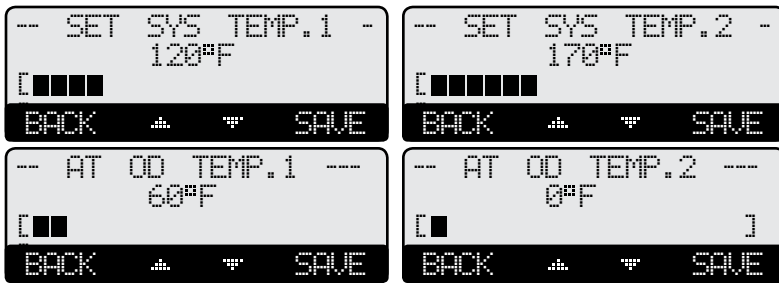

OUTDOOR CUTOFF TEMPERATURE

Adjustable Off, 20°F/-7°C - 100°F/38°C, On

Default: 70°F/21°C
in Set Point

Button: MENU/Outdoor Cutoff

- In Outdoor Reset mode, Outdoor Cutoff will always exist. However, in Set Point mode, if the outdoor sensor is installed, the Outdoor Cutoff screen will automatically appear after the temperature Set Point has been selected.
- When the outdoor temperature rises to the Outdoor Cutoff plus a 2°F differential, the SQ-Elite-8T will turn all boilers off. The System and Comb. Air relays that were energized will remain energized for the Run-On delay.
- The Outdoor Cutoff can be set to ON or OFF. In the ON position, the System Relay will run regardless of the Outdoor temperature and the burner stages will be active to hold the set point.
- In the OFF position, the System Relay will always be off and all stages will be off as well.



SETBACK

Adjustable 0°F/0°C to 80°F/44°C

Default: 0°F/0°C

Button: MENU/Setback

- The Setback feature can be used to provide the SQ-Elite-8T with a lower Set Point when less load is required.
- In Heating applications, when the outdoor temperature falls to the adjustable Outdoor Cutoff temperature, the SQ-Elite-8T will control and sequence the boiler stages to hold the calculated temperature.
- When the outdoor temperature rises to the Outdoor Cutoff plus a 2°F differential, the SQ-Elite-8T will turn all boilers off. The System, Combustion Air Damper, and any other Pump or valve relays that were energized will remain energized for the Run-On delay and then de-energize.
- In Cooling applications, when the outdoor temperature rises to the adjustable Outdoor Cutoff temperature, the SQ-Elite will control and sequence the cooling unit stages to hold the Set Point temperature.
- In addition, the Outdoor Cutoff can be set to ON or OFF. In the ON option, the System Relay will run regardless of the Outdoor temperature and the burner stages will be active to hold the target water temperature.
- In the OFF position, the system pump will always be off and all stages will be off as well.



DAY/NIGHT SCHEDULES

Button: MENU/Setback/Day Schedules/Night Schedule

- The SQ-Elite has two levels of heat or cool. The Day level is used when a building is occupied and people are active.
- The Night (Setback) level is used when a building is not occupied, or when people are sleeping. This setting reduces the calculated temperature in Heating and increase it in Cooling by the Setback setting based on the provided schedule. In Heating, if the Day calculated water temperature was 150°F and the Setback was 20°F, the Night Schedule will run at (150°F - 20°F) = 130°F.
- If the Boost feature is being used, it uses the Day Schedule as a Boost ending point. That is, if the Day Schedule is set to start at 6:00AM, the Boost was set to 10°F, and the Boost Period was 30 minutes, the Boost will start at 5:30AM. Then, when in Boost, SQ-Elite-8T will raise the calculated water temperature by the Boost amount. Using the previous example, at 5:30AM the SQ-Elite-8T will raise the calculated water to 170°F (150°F + 20°F) until 6:00AM where it will drop back to the normal calculated temperature of 150°F.



SPECIFICATIONS:

Voltage Input:	120 VAC 60 Hz
Power Consumption:	12 VA Max
Operating Temperature:	20°F/-7°C to 120°F/49°C
Operating Humidity:	20% to 80%
Dimensions:	11"W x 9" H x 3 3/4"
Weight:	2.5 pounds

SQ-Elite Specifications:

Lead Stage Rotation:	Time (1 to 999 Hours (41 days)), Manual, First-On/First-Off
SQ-Elite-8 Outputs and LEDs:	11 N.O. S.P.S.T (8 Stages, 1 System, 1 DHW Pump, 1 Combustion Air)
SQ-Elite-8 Inputs:	1 Sys(Temp), 1 Outdoor, Return Temp, DHW Temp, Ext Setback/Shutdown, Prove
Stage Modes:	Auto, Standby, Off, On
Standby Time (PID only):	1 to 60 minutes
Output Built-in Relay Ratings:	2 Amp inductive (Maximum of 1/4 HP) at 120 VAC 60 Hz
Add-On SQ-Elite-EXT Panels:	up two SQ-Elite-EXT Panels using RS485
Temperature Display:	Fahrenheit or Celsius.
Display:	Graphical Alphanumeric (7 rows x 21 char. each)
Temperature Sensor Ranges:	-35°F to 250°F
Outdoor Cutoff Range:	20°F/-17°C to 100°F/38°C, ON and OFF
Set Point:	-10°F/-23°C to 230°F/110°C
External Set Point:	-10°F/-23°C to 240°F/116°C using 4-20mA EMS Interface (optional)
Reset Ratio Range (Outdoor Reset Only):	(1:4) to (8:1) (Outdoor : System Water), and Custom Reset Ratio
Offset Adjustment (Outdoor Reset Only):	minus -40°F/-22°C to plus 40°F/22°C
Minimum Target (Outdoor Reset Only):	70°F/21°C to 170°F/77°C
Maximum Target (Outdoor Reset Only):	90°F/38°C to 240°F/116°C
Reaction Time (PID only):	1 to 10 minutes
Minimum Run-Time (PID only):	0 to 60 minutes
Purge Delay (PID only):	0.0 to 10.0 minutes
Last Stage Hold (PID only):	0°F/0°C to 30°F/17°C
Throttle Range (OSS only):	2°F/1°C to 20°F/11°C
Domestic Hot Water Priority Options:	Parallel Piping with Priority or without Priority and Primary Secondary
Pump Run-On:	0 to 60 minutes
Pump Exercise:	Yes or No
Schedules:	1 Day and 1 Night (Setback) settings per day
Night Setback:	0°F/0°C to 80°F/44°C
Power Backup:	Lithium coin battery, 100 days minimum 5 year replacement (Maintains Clock in power outages).
External Inputs:	Shutdown Input, and Prove Input. (Dry Contacts Only)
Season:	Winter and Summer.

SQ-Elite-EXT Specifications:

Extension Numbering:	Toggle Switch A or B
LED:	1 Power (Dual Color Green (A)/Red (B)), 1 Communication, 8 Stage Output relays (Dual Color Green (A)/Red (B))
Stage Outputs:	8 N.O. S.P.S.T.
Output Built-in Relay Ratings:	2 Amp inductive (Maximum of 1/4 HP) at 120 VAC 60 Hz
Connection to SQ-Elite and another SQ-Elite-EXT:	Two RS485